

ZEUS HYDRATECH LTD
Global Suppliers of Premium Hydraulic Components

Official UK Distributor for Continental Hydraulics

T: +44(0)1172 130042. E: sales@zeushydratech.com. W: zeushydratech.com

VED03 G Series

Proportional Directional Control Valves with Integrated Digital Electronics

DESCRIPTION

VED03 G series Proportional valves are Direct Operated with Integrated Digital Electronics.

VED03GL style uses a compact box and M12- 5 Pin connection. Control interface option include Analog, IO-Link and CANopen inputs.
See pages 3 - 5 for more details.

VED03MG style uses the industry standard common 7 Pin connection and Analog inputs.
See pages 6 - 9 for more details.

VED03GH style provides for a variety of Fieldbus communication options.
See pages 10 - 14 for more details.

For all other performance data and accessories.
See pages 15 - 18

PERFORMANCE (Mineral oil with viscosity of 36 cSt at 50°C and p = 140 bar)

Max operating pressure: P - A - B ports T port	PSI (bar)	5000 (350) 3000 (210)
Nominal flow with Δp 10 bar P-T	l/min	1 - 4 - 12 - 18 - 30
Response times	see page 16	
Hysteresis	% of Q max	< 3%
Repeatability	% of Q max	< ±1%
Electrical characteristics	see data under each style	
Ambient temperature range	°F (°C)	-4 / 140 (-20 / +60)
Fluid temperature range	°F (°C)	-4 / 176 (-20 / +80)
Fluid viscosity range	cSt	10 - 400
Fluid contamination degree	according to ISO 4406:1999 class 18/16/13	
Recommended viscosity	cSt	25
Mass: Single solenoid valve Double solenoid valve	lbs (kg)	4.2 (1.9) 5.3 (2.4)

VED03GL

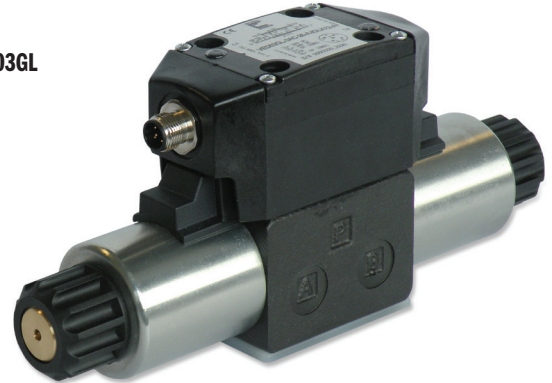

VED03MG

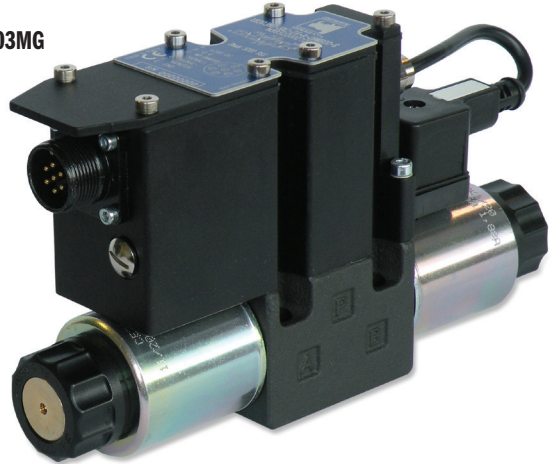

VED03GH

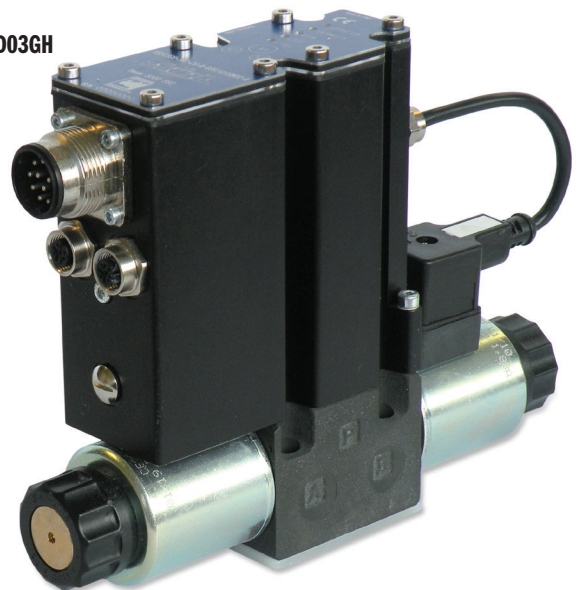

VED03 G Series

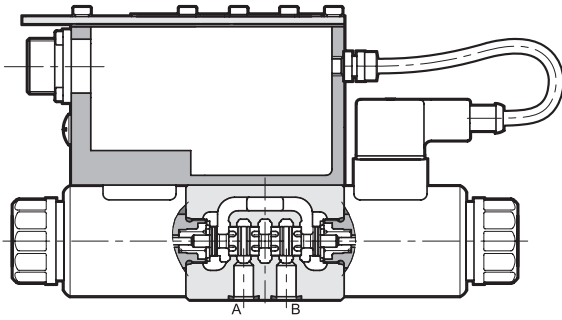

OPERATING PRINCIPLE

- The VED03 G* are proportional directional valves, direct operated, with digital integrated electronics and with mounting interface according to ISO 4401-03 standards.
- They control the positioning and the speed of hydraulic actuators.
- They are available with different types of electronics, with analogue or fieldbus interfaces.
- The valves are easy to install. The driver manages digital settings directly.

HYDRAULIC SYMBOLS (typical)

VED03*G*-3AC

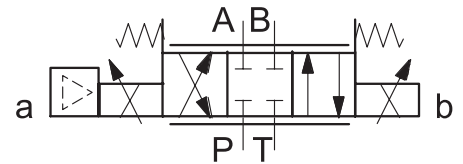

VED03*G*-3FC

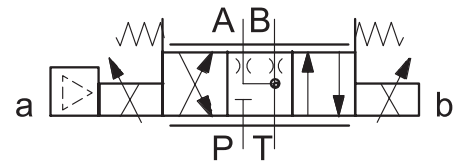

MOUNTING INTERFACE

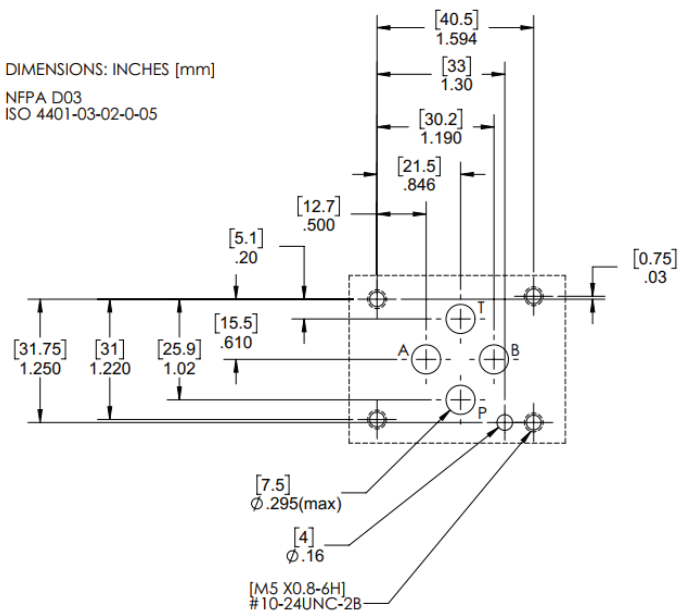

VED03 G Series

IDENTIFICATION CODE: Compact Electronics

VED03GL - - - - - **K12** - _____ DESIGN LETTER

Proportional D03 Direct Operated Directional Control with Digital On-Board and Compact Box

Low Profile Connection Box with M12 A 5 Pin (Male)

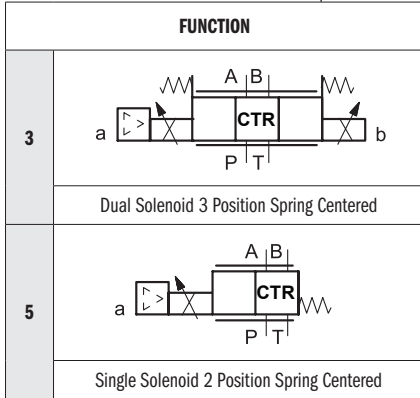

SEALS	
CODE	DESCRIPTION
A	BUNA (STD)
G	VITON

NOMINAL CONTROLLED FLOW with ΔP 10 Bar P-T	
CODE	FLOW RATE
01	1 l/min
04	4 l/min
08	8 l/min
16	16 l/min
16/08	16 (P-A) / 8 (P-B) l/min
26	26 l/min
26/13	26 (P-A) / 13 (P-B) l/min

CONTROL INTERFACE	
CODE	DESCRIPTION
E0	Analog Voltage ($\pm 10V$)
E1	Analog Current (4-20mA)
IOL	IO-Link Interface
CA	CANopen Interface

SPOOLS				
NAME	SYMBOLS	DESCRIPTION	APPLICATION	FUNCTION MATCHING
AC		METER IN / METER OUT	MOTION CONTROL	3, 5
FC				

Note: Function Code 5 valve only available with solenoid supplied on A port end. (P-B / A-T)

TYPICAL ORDERING CODE:
VSD03GL-3AC-08 -A-IOLK12-*

VED03 G Series
VED03GL - COMPACT ELECTRONICS

In versions 'IOL' and 'CA' pin 3 and pin 5 are galvanic isolated up to 100 V to avoid earth loops.
 In IO-Link networks, the length of the connecting cable is limited to 20 meters.

VED03GL Electrical Characteristics

Command signal: voltage (E0) current (E1)	V DC mA	±10 (Impedance Ri = 11 kOhm) 4 - 20 (Impedance Ri = 58 Ohm)
Monitor signal: voltage (E0) current (E1)	V DC mA	0 - 5 (Impedance Ro > 1 kOhm) 4 - 20 (Impedance Ro = 500 Ohm)
IO-Link communication (IOL): Data rate	kBaud	IO-Link Port Class B 230.4
Can Open communication (CA): Data rate	kbit	10 - 1000
Data register (IOL and CA versions only)		Solenoid voltage supply, solenoid faults (short circuit, bad config, internal), box temperature, switch-on time, vibrations
Connection		5-pin M12 code A (IEC 61076-2-101)

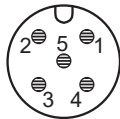
Pin tables
'E0' connection

Pin	Values	Function
2	24V DC	Supply voltage (solenoid and logic)
5	0V	
1	± 10V	Command
3	0V	Command reference
4	0 - 5V	Monitor (0V reference: pin 5)

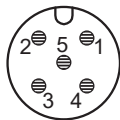
'E1' connection

Pin	Values	Function
2	24V DC	Supply voltage (solenoid and logic)
5	0V	
1	4 - 20 mA	Command
3	0V	Command reference
4	4 - 20 mA	Monitor (0V reference: pin 5)

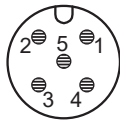
'IOL' connection

Pin	Values	Function
2	2L+ 24V DC	Supply of the power stage
5	2L- 0V (GND)	Internal galvanic isolation from PIN 3
1	1L+ +24V DC	IO-Link supply voltage
3	1L- 0V (GND)	
4	C/Q	IO-Link Communication

'CA' connection

Pin	Values	Function
1	CAN_SH	Shield
2	24V DC	Supply voltage
3	0V (GND)	
4	CAN H	Bus line (high)
5	CAN_L	Bus line (low)

VED03 G Series

VED03JL - OVERALL AND MOUNTING DIMENSIONS

Dimensions inch (mm)

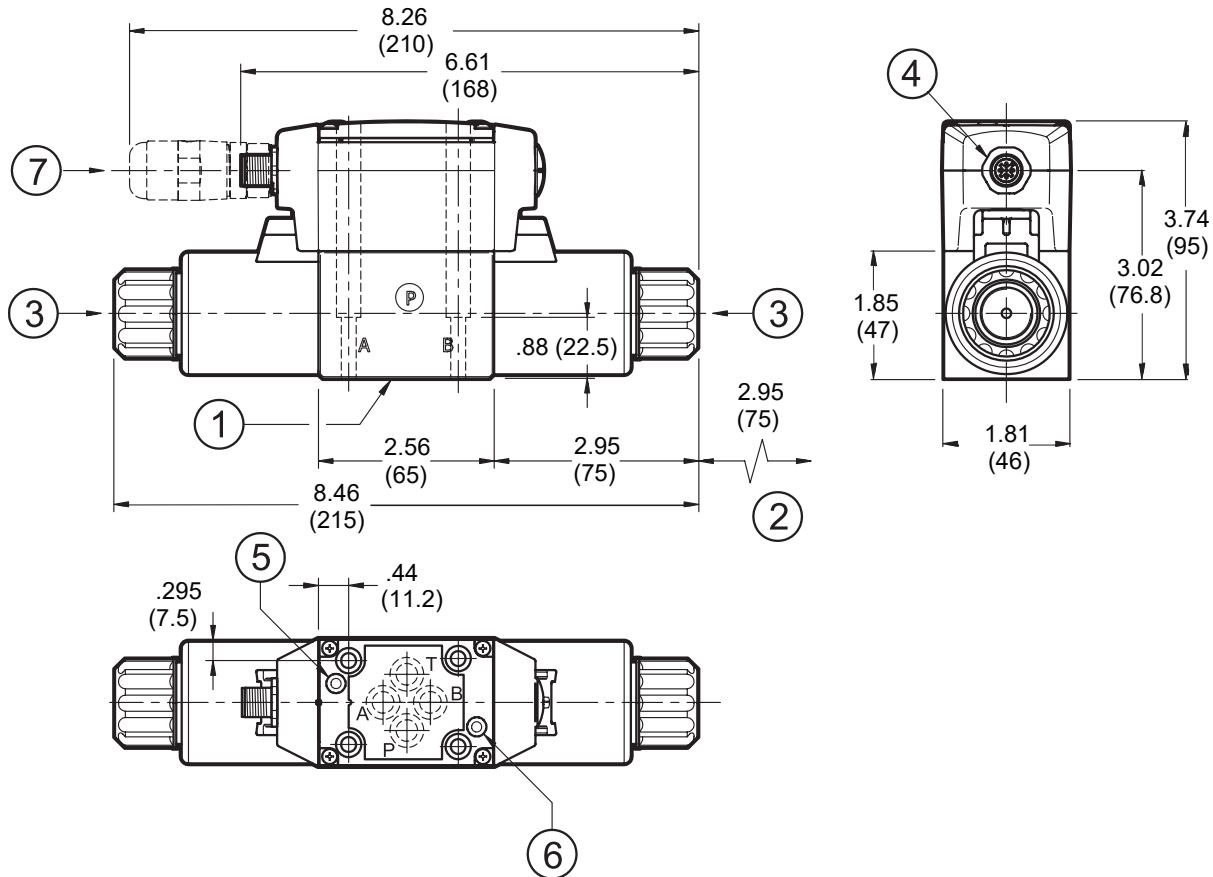

VED03GL-5 K12**

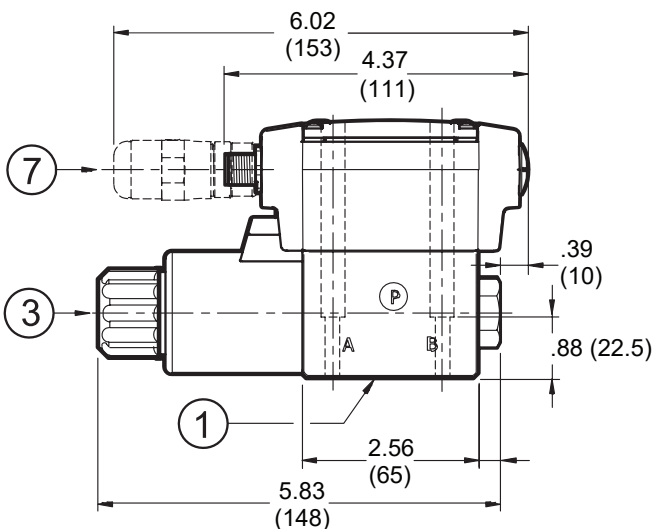

Valve Bolts: 4 SHC screws 10-24 NC x 1.25" ASTM A574
Torque: 4-6 lb.-ft. (5.4 - 8 Nm)
Threads of mounting holes: 10-24 NC

1	Mounting surface with sealing rings: QTY 4 O-Ring size AS568-012 / 90 Shore
2	Coil removal space
3	Standard manual override embedded in the solenoid tube
4	Connection M12 A 5 pin
5	L1 LED
6	L2 LED
7	Mating connector M12 5 poles - code A, female. To be ordered separately.

VED03 G Series

IDENTIFICATION CODE: Standard (7 Pin) Electronics

VED03MG - - - - - **D** - _____ DESIGN LETTER

Proportional D03 Direct Operated
with Digital On-Board Controls
Standard 7 PIN Connection

FUNCTION	
3	<p style="text-align: center;">Dual Solenoid 3 Position Spring Centered</p>
5	<p style="text-align: center;">Single Solenoid 2 Position Spring Centered</p>

SEALS	
CODE	DESCRIPTION
A	BUNA (STD)
G	VITON

REFERENCE SIGNAL	
CODE	DESCRIPTION
E0	Voltage ± 10 V (STD)
E1	Current 4-20 mA

NOMINAL CONTROLLED FLOW with ΔP 10 Bar P-T	
CODE	FLOW RATE
01	1 l/min
04	4 l/min
08	8 l/min
16	16 l/min
16/08	16 (P-A) / 8 (P-B) l/min
26	26 l/min
26/13	26 (P-A) / 13 (P-B) l/min

CONNECTION	
CODE	DESCRIPTION
OBW	On board electronics - Internal Enable monitor signal PIN F to PIN B
OBC	On board electronics - PIN C Enable monitor signal PIN F to PIN B
OBM	On board electronics - Internal Enable monitor signal PIN F to PIN C

SPOOLS				
NAME	SYMBOLS	DESCRIPTION	APPLICATION	FUNCTION MATCHING
AC		METER IN / METER OUT	MOTION CONTROL	3, 5
FC				

Note: Function Code 5 valve only available with solenoid supplied on A port end. (P-B / A-T)

TYPICAL ORDERING CODE:
VED03MG-3AC-26-A-OBWE0D- *

VED03 G Series

VED03MG ELECTRONICS COMMON DATA

Duty cycle		100% (continuous operation)
Protection class according to EN 60529		IP65 / IP67
Supply voltage	V DC	24 (from 19 to 30 VDC), ripple max 3 Vpp
Power consumption	VA	25
Maximum solenoid current	A	1.88
Fuse protection, external	A	3
Managed breakdowns		Overload and electronics overheating, LVDT sensor error, cable breakdown, supply voltage failure
Electromagnetic compatibility (EMC) emissions EN 61000-6-4, immunity EN 61000-6-2		According to 2014/30/EU standards

VED03MG - STANDARD ELECTRONICS

3.1 - Electrical characteristics

Command signal: voltage (E0) current (E1)	V DC mA	±10 (Impedance Ri = 11 kOhm) 4 - 20 (Impedance Ri = 58 Ohm)
Monitor signal: voltage (E0) current (E1)	V DC mA	0 - 5 (Impedance Ro > 1 kOhm) 4 - 20 (Impedance Ro = 500 Ohm)
Communication for diagnostic		LIN-bus Interface (by means of the Programming Box)
Connection		6 pin + PE (MIL-C-5015-G - DIN EN 175201-804)

On-board electronics diagrams

VERSION OBC - External Enable

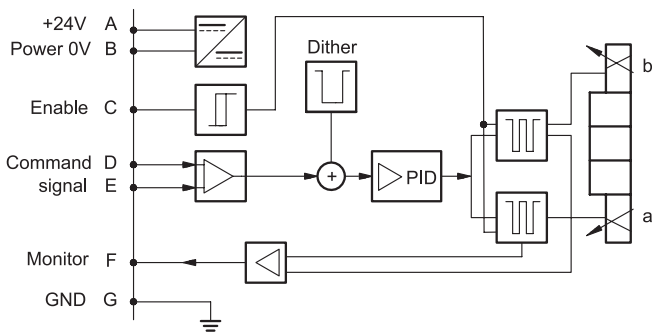

VERSION OBW - Internal Enable

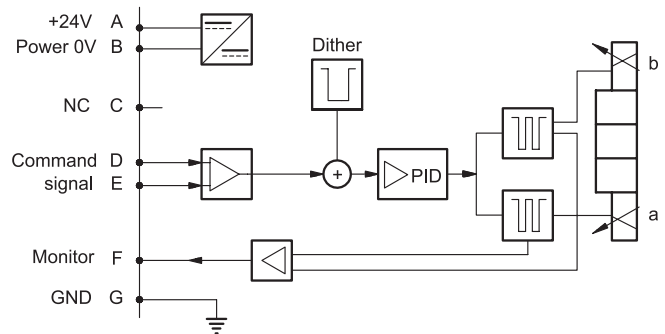

VERSION OBM - 0V Monitor

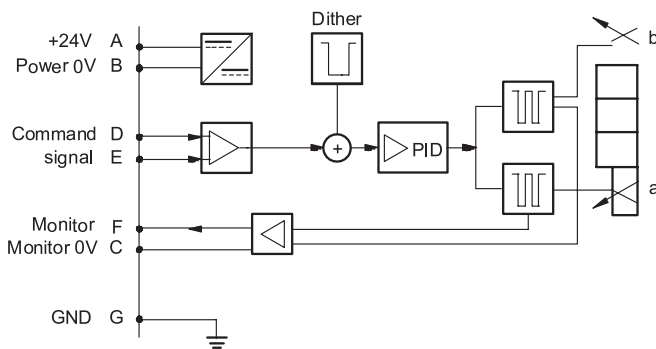

VED03 G Series

VED03MG Versions with voltage command (E0)

The reference signal is between -10V and +10V on double solenoid valve, and 0 - 10V on single solenoid valve.
 The monitor feature of versions OBW and OBM becomes available with a delay of 0.5 sec from the power-on of the card.

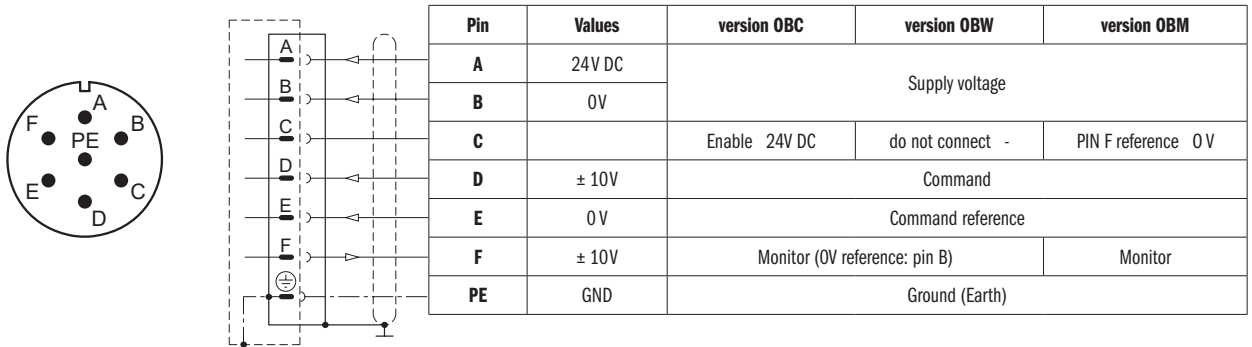
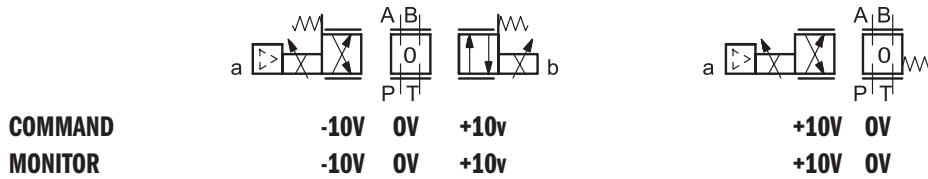

VDD03MG Versions with current command (E1)

The reference signal is supplied in current 4 - 20 mA. If the current for command is lower, the card shows a breakdown cable error. To reset the error is sufficient to restore the signal.

The monitor feature of versions OBW and OBM becomes available with a delay of 0.5 sec from the power-on of the card.

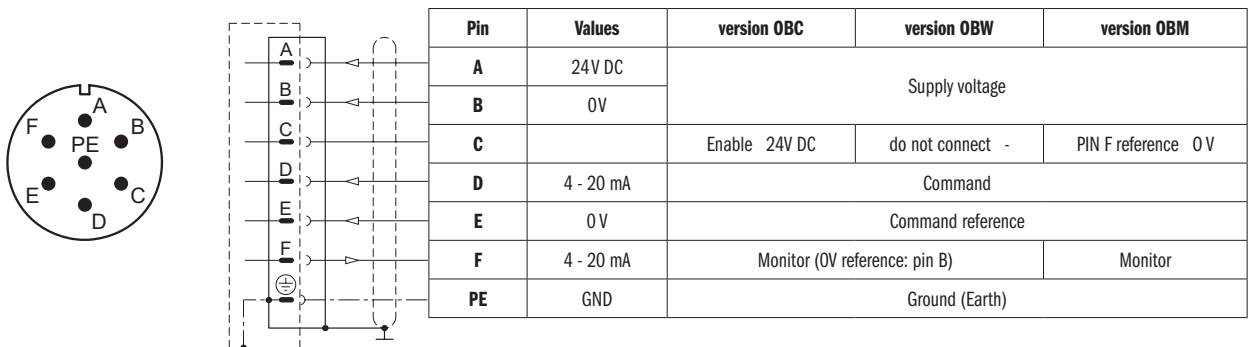
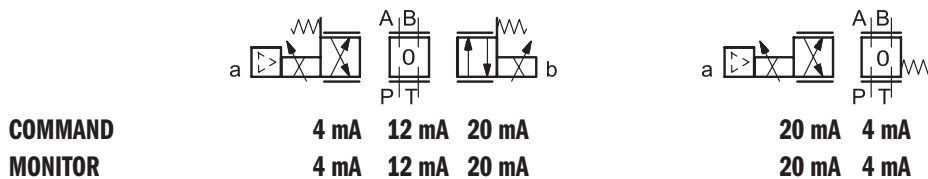

VED03 G Series
VED03MG - OVERALL AND MOUNTING DIMENSIONS

Dimensions inch (mm)

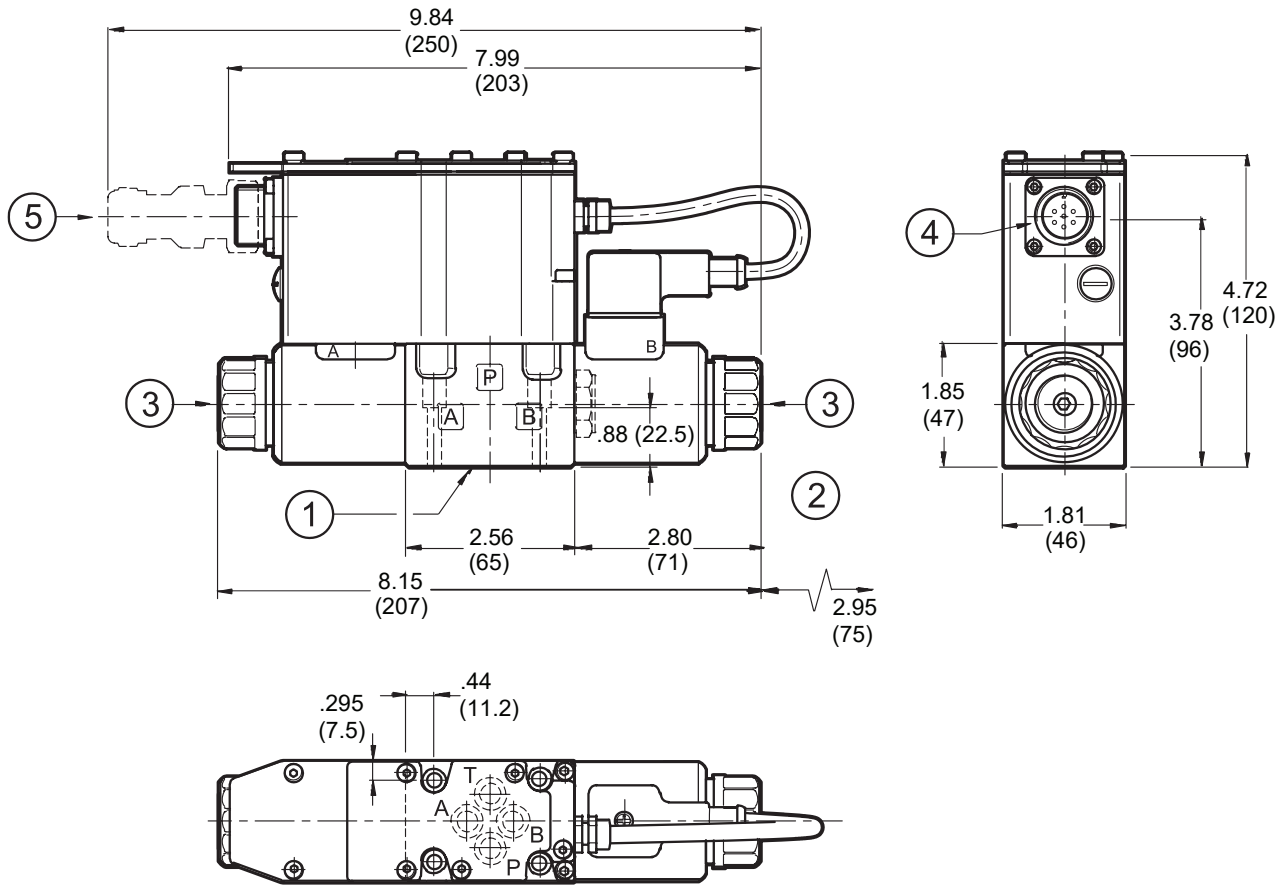
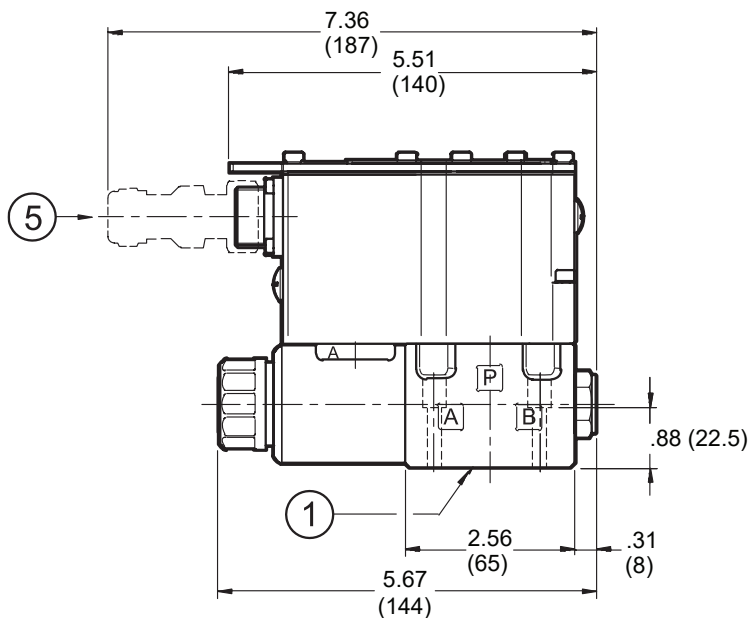
VED03MG-3*

VED03MG-5*

Valve Bolts: 4 SHC screws 10-24 NC x 1.25" ASTM A574
Torque: 4-6 lb.-ft. (5.4 - 8 Nm)
Threads of mounting holes: 10-24 NC

1	Mounting surface with sealing rings: QTY 4 O-Ring Size AS568-012 / 90 Shore
2	Coil removal space (solenoid B only)
3	Manual override by pin embedded in the solenoid tube
4	Main connection 6 pin + PE
5	Mating connector 6 poles + PE, female type MIL-5015-G To be ordered separately.

VED03 G Series

IDENTIFICATION CODE: Fieldbus Electronics

VED03GH - - - - - **K16** - ——— DESIGN LETTER

Proportional D03 Direct Operated Control with Digital On-Board and Fieldbus Controls

FUNCTION	
3	<p style="text-align: center;">Dual Solenoid 3 Position Spring Centered</p>
5	<p style="text-align: center;">Single Solenoid 2 Position Spring Centered</p>

SEALS	
CODE	DESCRIPTION
A	BUNA (STD)
G	VITON

NOMINAL CONTROLLED FLOW with ΔP 10 Bar P-T	
CODE	FLOW RATE
01	1 l/min
04	4 l/min
08	8 l/min
16	16 l/min
16/08	16 (P-A) / 8 (P-B) l/min
26	26 l/min
26/13	26 (P-A) / 13 (P-B) l/min

CONNECTIONS (Select one for each X connection)		
	CODE	DESCRIPTION
X1 Main Connector Configuration (Select One)	D1	One Command
	D0	Full Digital (on request - available for reference signal FD type Only)
X2, X3 Fieldbus type (Select One)	CA	CAN Open
	PD	PROFIBUS DP
	EC	EtherCAT
	EN	Ethernet / IP
	PN	Profinet
	PL	PowerLink
X7 Digital Transducer (Select One)	0	None
	1	SSI Type
	2	Encoder Type
X4 Analog transducer (Select One)	0	None
	1	Single / Double Transducer

SPOOLS				
NAME	SYMBOLS	DESCRIPTION	APPLICATION	FUNCTION MATCHING
AC		METER IN / METER OUT	MOTION CONTROL	3, 5
FC				

CONTROL INTERFACE	
CODE	DESCRIPTION
E0	Analog Voltage (±10V)
E1	Analog current (4-20MA)
FD	Full Digital Version (on Request)

Note: Function Code 5 valve only available with solenoid supplied on A port end. (P-B / A-T)

TYPICAL ORDERING CODE:
VSD03GH-3AC-26-A-E0K16D1EN00-*

VED03 G Series

VED03GH - FIELDBUS ELECTRONICS

The 11+ PE pin connection allows separate supply voltage for electronics and solenoids.

VED03GH Electrical characteristics

Command signal: voltage (E0) current (E1) digital (FD)	V DC mA	±10 (Impedance Ri = 11 kOhm) 4 - 20 (Impedance Ri = 58 Ohm) via fieldbus
Monitor signal: voltage (E0) current (E1)	V DC mA	±10 (Impedance Ro > 1 kOhm) 4 - 20 (Impedance Ro = 500 Ohm)
Communication / diagnostic		via Bus register
Communication interface standards CAN Open PROFIBUS DP EtherCAT, Ethernet /IP, Profinet, PowerLink		EN 50325-4 + DS408 EN 50170-2 / IEC 61158 IEC 61158
Communication physical layer CAN Open PROFIBUS DP EtherCAT, Ethernet /IP, Profinet, PowerLink		optical insulated CAN ISO 11898 optical insulated RS485 fast ethernet, insulated 100 Base TX
Power connection		11 pin + PE (DIN 43651)



COMMAND	-10V	0V	+10v	4 mA	12 mA	20 mA
MONITOR	-10V	0V	+10v	4 mA	12 mA	20 mA

X1 Main connection pin table

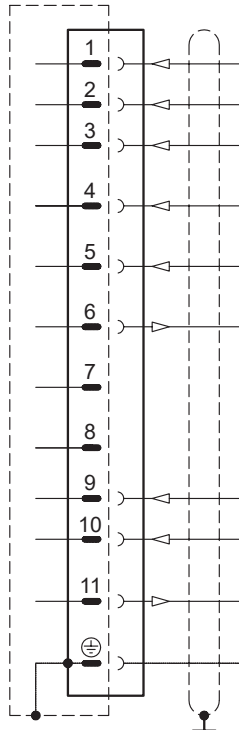
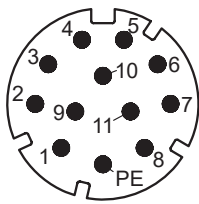

D1: one command

Pin	Values	Function
1	24V DC	Main supply voltage
2	0V	
3	24V DC	Enable
4	± 10V (E0) 4 - 20 (E1)	Command
5	0V	Command reference signal
6	± 10V (E0) 4 - 20 (E1)	Monitor (0V reference pin 10)
7	NC	do not connect
8	NC	do not connect
9	24V DC	Logic and control supply
10	0V	
11	24V DC	Fault (0V DC) or normal working (24V DC) (0V reference pin 2)
12	GND	Ground (Earth)

D0: full digital

Pin	Values	Function
1	24V DC	Main supply voltage
2	0V	
3	24V DC	Enable
4	NC	do not connect
5	NC	do not connect
6	NC	do not connect
7	NC	do not connect
8	NC	do not connect
9	24V DC	Logic and control supply
10	0V	
11	24V DC	Fault (0V DC) or normal working (24V DC) (0V reference pin 2)
12	GND	Ground (Earth)

VED03 G Series
VED03G H FIELDBUS connections

Please wire following guidelines provided by the relative standards communication protocol.

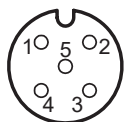
Communication connection CA (CAN Open)
X2 (IN) connection: M12 A 5 pin female

Pin	Values	Function
1	CAN_SH	Shield
2	NC	Do not connect
3	GND	Signal zero data line
4	CAN_H	Bus line (high)
5	CAN_L	Bus line (low)

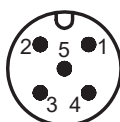
X3 (OUT) connection: M12 A 5 pin male

Pin	Values	Function
1	CAN_SH	Shield
2	NC	Do not connect
3	GND	Signal zero data line
4	CAN_H	Bus line (high)
5	CAN_L	Bus line (low)

Communication connection PD (PROFIBUS DP)
X2 (IN) connection: M12 B 5 pin male (IN)



Pin	Values	Function
1	+5 V	Termination supply signal
2	PB_A	Bus line (high)
3	0 V	Data line and termination signal 0
4	PB_B	Bus line (low)
5	SHIELD	

X3 (OUT) connection: M12 B 5 pin female

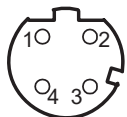
Pin	Values	Function
1	+5 V	Termination supply signal
2	PB_A	Bus line (high)
3	0 V	Data line and termination signal 0
4	PB_B	Bus line (low)
5	SHIELD	

Communication connections: EC (EtherCat), EN (Ethernet/IP), PN (PROFINET), PL (POWERLINK)
X2 (IN) connection M12 D 4 pin female

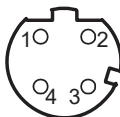
Pin	Values	Function
1	TX+	Transmitter
2	RX+	Receiver
3	TX-	Transmitter
4	RX-	Receiver
HOUSING	SHIELD	

X3 (OUT) connection: M12 D 4 pin female

Pin	Values	Function
1	TX+	Transmitter
2	RX+	Receiver
3	TX-	Transmitter
4	RX-	Receiver
HOUSING	SHIELD	

Note: Shield connection on connector housing is recommended.

VED03 G Series

Digital transducer connection

X7 connection: M12 A 8 pin female)

VERSION 1: SSI type

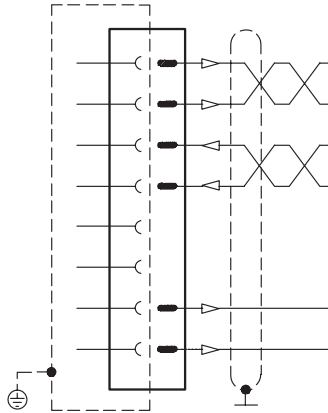
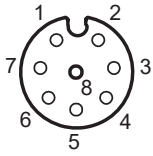

Pin	SSI Values	Function	Notes
1	CLK+	Serial synchronous clock (+)	Input - digital signal
2	CLK-	Serial synchronous clock (-)	
3	MISO+	Serial position data (+)	
4	MISO-	Serial position data (-)	
5	NC	-	do not connect
6	NC	-	
7	+24 V	transducer power supply	Output power supply
8	0 V	-	Common GND

VERSION 2: ENCODER type

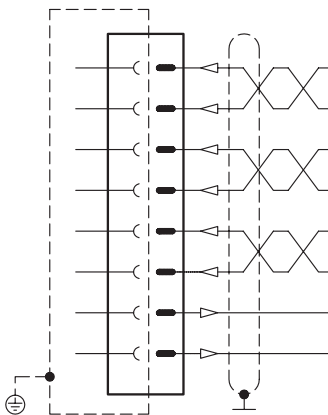
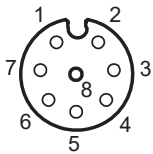

Pin	SSI Values	Function	Notes
1	ENC_Z+	input channel Z+	Input - digital signal
2	ENC_Z-	input channel Z-	
3	ENC_A+	input channel A+	
4	ENC_A-	input channel A-	
5	ENC_B+	input channel B+	
6	ENC_B-	input channel B-	
7	+5 V	transducer power supply	Output power supply
8	0 V	-	Common GND

Analogue transducer connection X4 connection: M12 A 4 pin female

VERSION 1: single / double transducer (single or double is a software-selectable option)

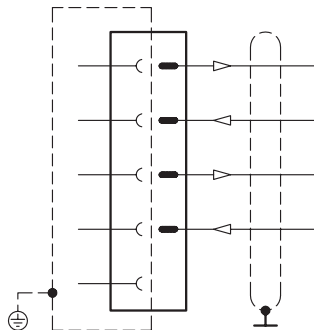

Pin	Values	Notes
1	+24V	Remote transducer power supply (out) 100 mA
2	±10 V 4 ±20 mA	Input signal of transducer 1 (range software selectable)
3	0V	Common reference signal for transducer power and signals
4	±10 V 4 ±20 mA	Input signal of transducer 2 (range software selectable)
5	-	

VED03 G Series

VED03GH - OVERALL AND MOUNTING DIMENSIONS

Dimensions inch (mm)

VED03GH-3**

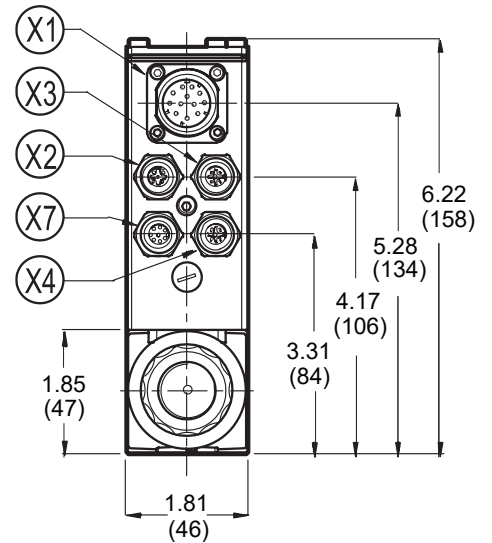
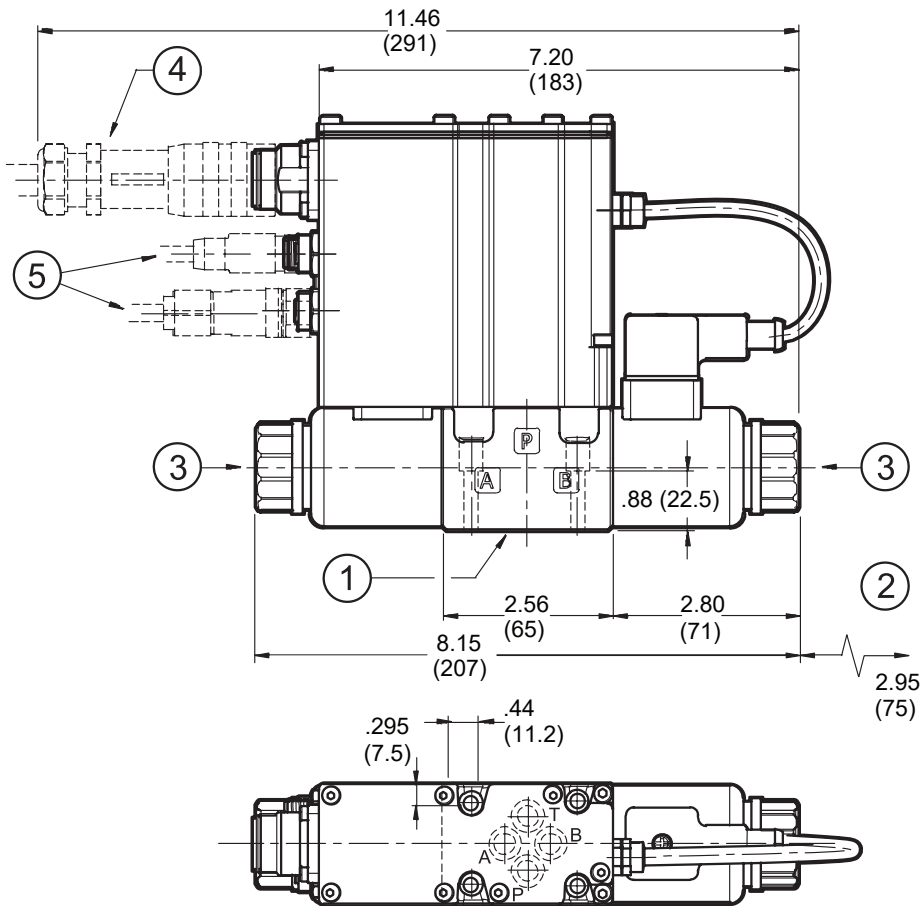

Note: Depending on the chosen version, X4 and X7 connections may not be present. Please refer to page 10-12 for connection descriptions and pinout.

VED03GH-5**

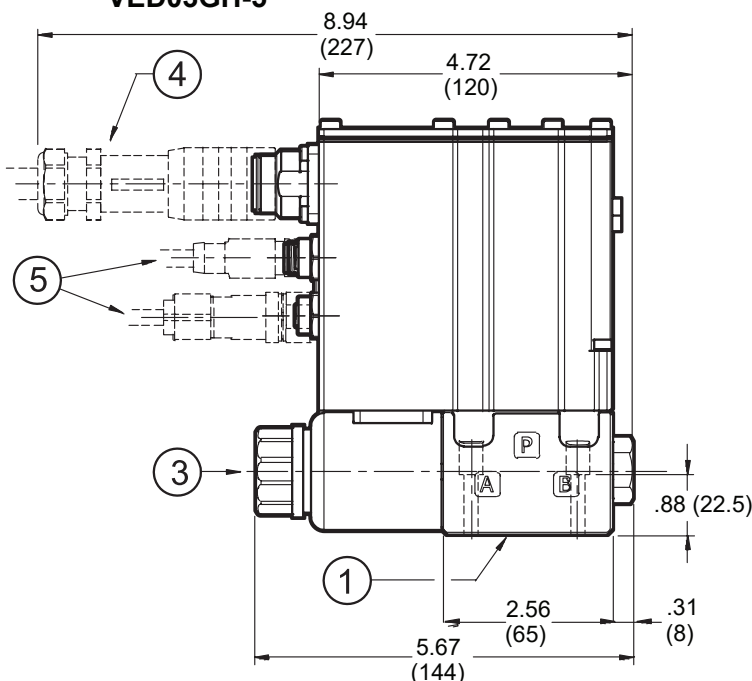

Valve Bolts: 4 SHC screws 10-24 NC x 1.25" ASTM A574
Torque: 4-6 lb.-ft. (5.4 - 8 Nm)
Threads of mounting holes: 10-24 NC

X1	Main connection 11 pin + PE
X2	Fieldbus communication (IN)
X3	Fieldbus communication (OUT)
X4	X4 connection for analogue transducer
X7	X7 connection for digital transducer

1	Mounting surface with sealing rings: QTY 4 O-Ring AS568-012 / 90 Shore
2	Coil removal space (solenoid B only)
3	Manual override by pin integrated in the solenoid tube
4	Mating connector 11 poles + PE To be ordered separately.
5	Mating connectors for fieldbus communication and signals To be ordered separately.

VED03 G Series

VED03 G Series - CHARACTERISTIC CURVES

(Obtained with mineral oil with viscosity of 36 cSt at 50°C and $p = 210$ bar)

Typical flow rate curves related to the reference signal and measured for the available spools.
The Δp values are measured between P and T valve ports.

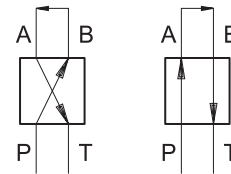

SPOOL TYPE AC01 / FC01

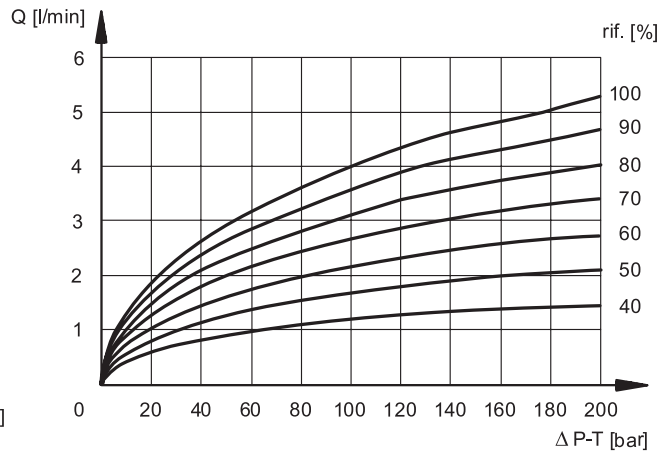
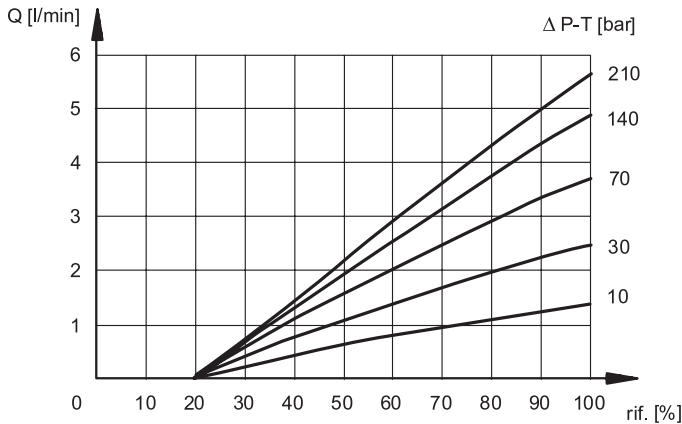

SPOOL TYPE AC04 / FC04

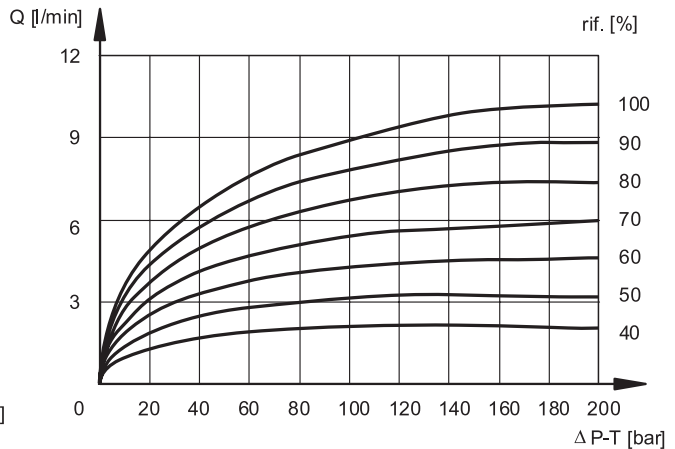
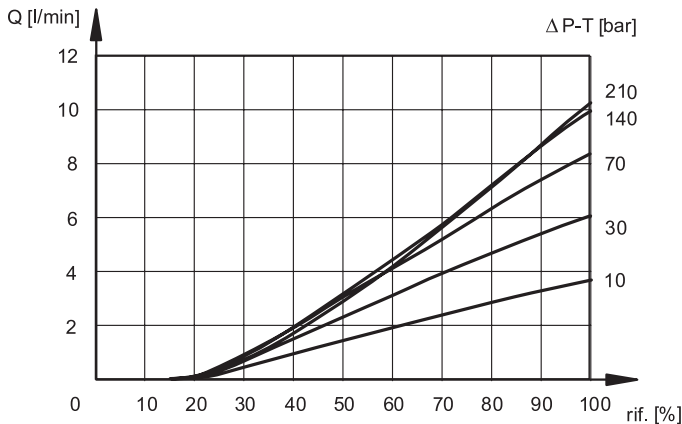

SPOOL TYPE AC08 / FC08

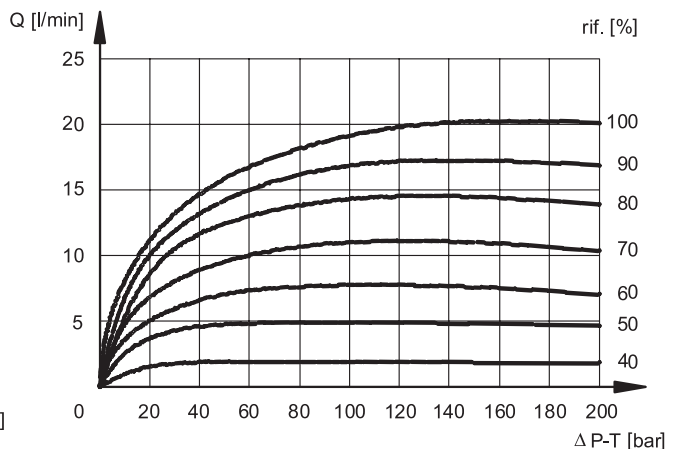
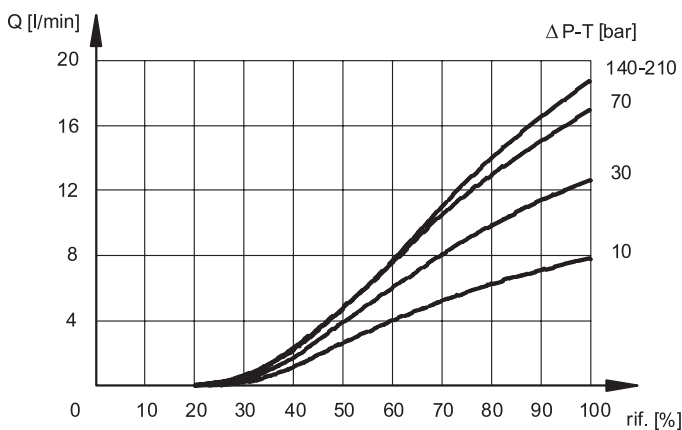

VED03 G Series

SPOOL TYPE AC16 / FC16

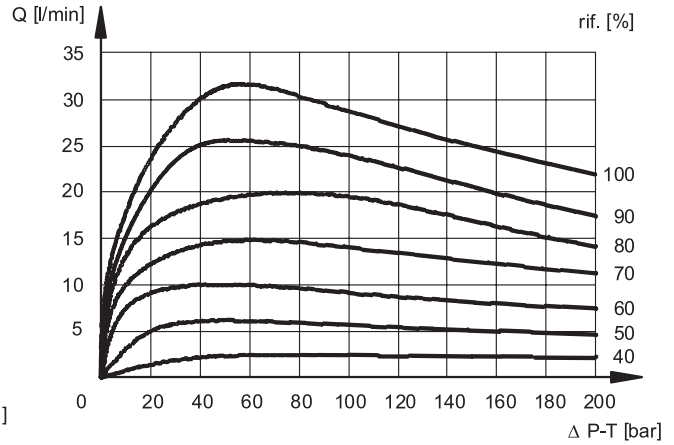
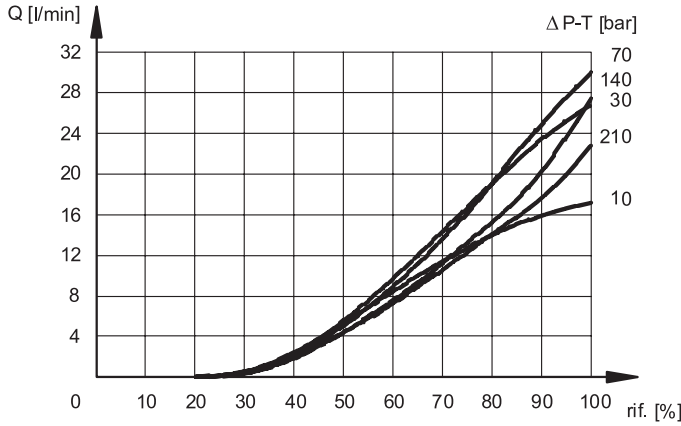

SPOOL TYPE AC26 / FC26

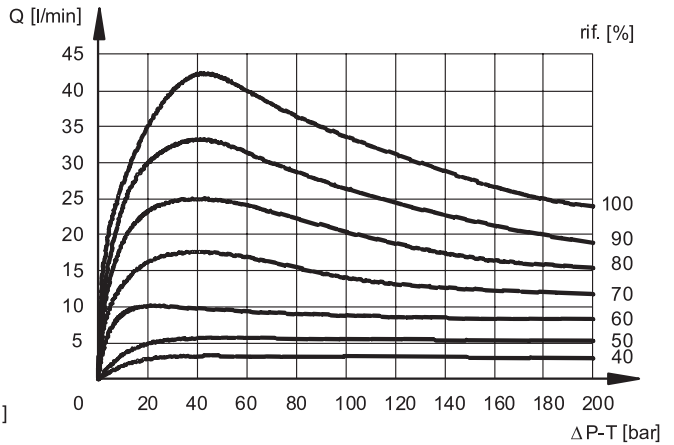
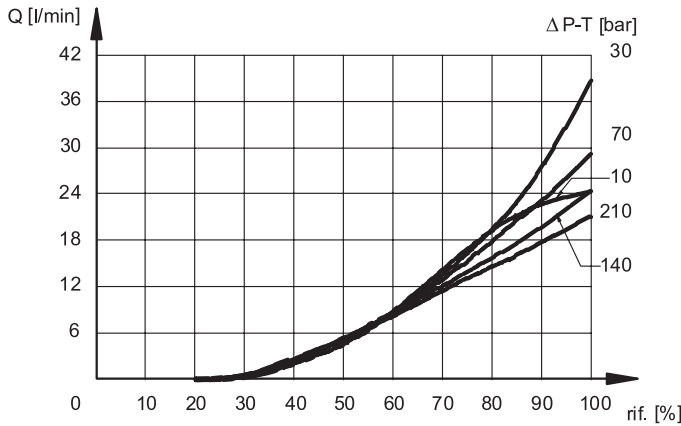

RESPONSE TIMES

(obtained with mineral oil with viscosity of 36 cSt at 50°C and p = 140 bar)

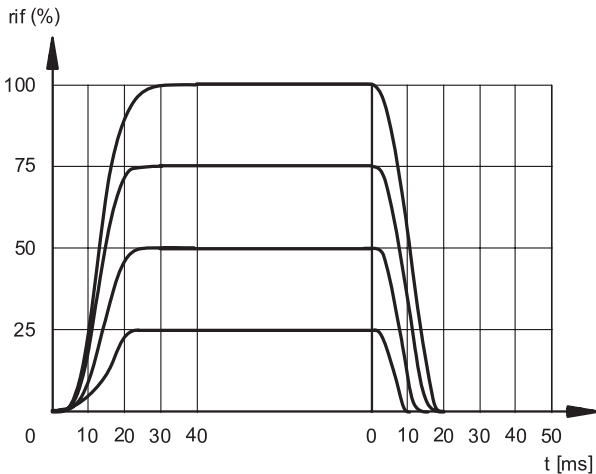

Common Conversions Formulas:

LPM to GPM (LPM x .2642 = GPM)

GPM to LPM (GPM x 3.785 = LPM)

Bar to PSI (Bar x 14.5 = PSI)

PSI to Bar (PSI x .06895 = Bar)

ACCESSORIES CATALOGS

VALVE ACCESSORIES
 Connectors and Cable Sets

Connectors and Cable Sets

Standard Directional Control Valves

Male Receptacles

VEA-3C-A
G 3/8" / 1001849

VEA-3MH-A
G 3/8" / 1001849

VEA-3L4-A
M12 (G 3/8") / 1001850

For the connector cable sets, see the table below. For the cable sets, see the table below.

For the connector cable sets	For the cable sets
1. Cable to connector A	1. Cable to connector A
2. Cable to connector B	2. Cable to connector B
3. Cable to connector C	3. Cable to connector C
4. Cable to connector D	4. Cable to connector D
5. Cable to connector E	5. Cable to connector E

Female Receptacles

VEA-3M-A
G 3/8" / 1001851
6 ft. cord

VEA-3L-A
M12 (G 3/8") / 264054
6 ft. cord

VEA-3D-A
G 3/8" / 1001851
6 ft. cord

DIN Connector
43550 Form A / ISO 4400

VEA-3E-A (6m) / 165639

VEA-3F-A (6m) / 165639

Cable Glands
VSD-HL-KD2

PC11 ISO
Strain Relief

www.continentalhydraulics.com - sales@conthyd.com

1027453 Rev 01/22 1/5

Connectors and Cables Sets
Form #1027453

VALVE ACCESSORIES
 Programming and Test Devices

Programming and Test Devices

For **IO-Link** and Proportional Valves with Integrated Electronics

OPERATING PRINCIPLE

The test device contains a test device with embedded cable to connect to the valve. It is used to program and test the valve. The software is available for download from our website.

The device is suitable for troubleshooting and functional testing of Continental proportional valves for open loop (type G, GH) and closed loop (type D, DM, DMH, and DHD) valves with IO-Link.

The software allows to check settings, diagnostics and errors to verify the desired parameter settings made in reality, adapting it to your system.

No additional power supply is required; the device uses the supply source coming from the system cable.

TECHNICAL CHARACTERISTICS

Power supply	VDC	24 (18 + 30)
Current consumption	mA	50
Valve side connection	VEA-PB1, VEA-PB2, VEA-PB12	6 poles M12 (2x4 + 4x2) (2x4 + 4x2) (2x4 + 4x2)
PC side connection	USB 2.0 cable	11 poles + PE (2x4 + 4x2)
Electromagnetic compatibility (EMC)		according to 2014/53/EU (EN 61000-6-4 (immunity) - EN 61000-6-2 (emissions))
Housing dimensions	mm	104x64x41 + 2000 (output cable)
Operating temperature range	°C	-20 / +60
Protection degree		IP 20

IDENTIFICATION CODE

VEA-PB1 + + =

For connecting type:

1	M12 (6 pole type G DM)
2	11 poles + PE (6 pole type G DM)
3	11 poles + PE (6 pole type G DM)

www.continentalhydraulics.com - sales@conthyd.com

1027454 Rev 01/22 1/4

Programming and Test Devices
Form #1027454