

Axialkolben-Verstellpumpen Baureihe J-V

Variable displacement axial piston pumps Series J-V

Pompe variabili a pistonni assiali Serie J-V

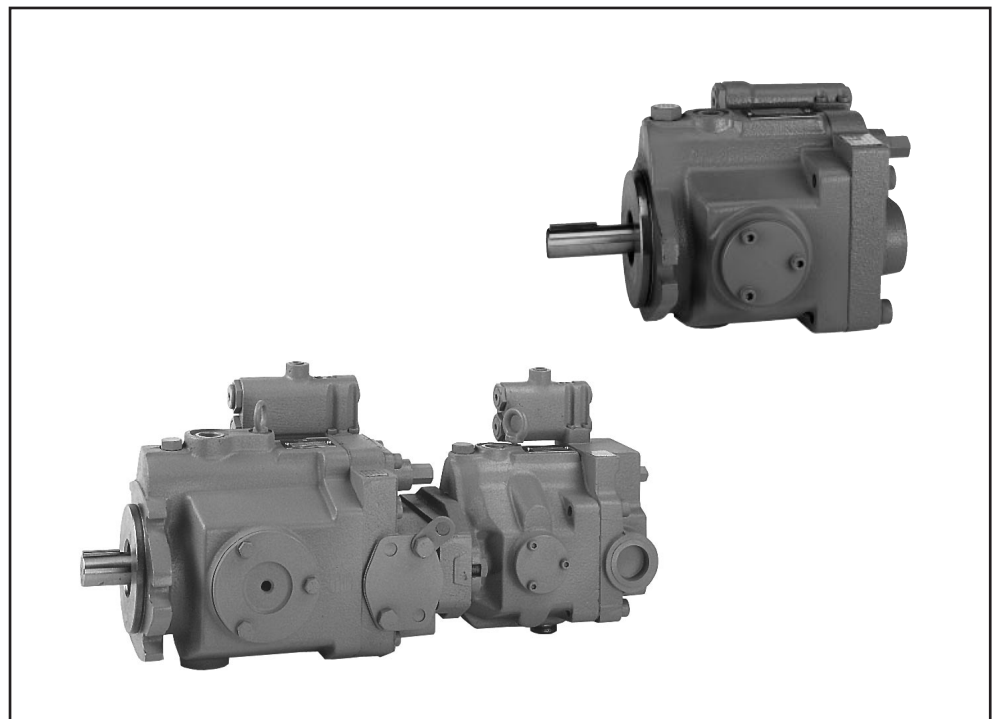

Axialkolben-Verstellpumpen
Variable displacement axial piston pumps
Pompe variabili a pistonni assiali

Baureihe J-V
Series J-V
Serie J-V

Inhaltsverzeichnis · Contens · Indice

Seite · Page · Pagina

Allgemeine Beschreibung	3
General description	
Descrizione generale	
Regel- und Verstellorgane	4
Control devices	
Dispositivi di regolazione	
Kenngrößen	6
Operating data	
Dati caratteristici	
Drehrichtung und Masse	7
Sense of rotation and weight	
Senso di rotazione e peso	
Nullhubdruckeinstellbereich mechanisch	7
Adjustable pressure range	
Campo di registrazione meccanica della pressione di azzeramento	
Typenschlüssel bei Verwendung von	
Model code	
Chiave di ordinazione con l' utilizzo del	
- Regler A, Control A, Regolatore A	8
- Regler A-RC, Control A-RC, Regolatore A-RC	8
- Regler SA, Control SA, Regolatore SA	9
- Regler D, Control D, Regolatore D	9
- Regler CH, Control CH, Regolatore CH	10
- Regler CJ, Control CJ, Regolatore CJ	10
- Regler CP, Control CP, Regolatore CP	11
Kennlinien	
Characteristics	
Curve caratteristiche	
- Dynamisches Verhalten des Nullhubdruckreglers A	12
Dynamic performance of pressure compensator control A	
Prestazione dinamica del compensatore A	
- Geräuschmessungen (L_p - p_2)	12
Noise level (L_p - p_2)	
Livelli di rumorosità (L_p - p_2)	
- Wirkungsgrad, Förderstrom, Leistung (η , q_{ve} , P - p_2)	14
performance characteristic (η , q_{ve} , P - p_2)	
Rendimento, portata, potenza (η , q_{ve} , P - p_2)	
- Externer Leckstrom (q_{vd} - p_2)	16
External leakage flow (q_{vd} - p_2)	
Drenaggio esterno (q_{vd} - p_2)	
- Nullhubleistung (Pq_{vNull} - p_2)	17
Dead head horsepower (Pq_{vNull} - p_2)	
Potenza dispersa in compensazione (Pq_{vNull} - p_2)	
Geräteabmessungen	18
Installation dimension	
Dimensioni	
Durchtriebspumpen mit SAE-Anschluß	26
Through drive pumps with SAE connection size	
Pompe ad albero passante con attacco SAE	

Axialkolben-Verstellpumpen

Variable displacement axial piston pumps

Pompe variabili a pistoni assiali

Baureihe J-V
Series J-V
Serie J-V

Allgemeine Beschreibung · General description · Descrizione generale



Bild / Fig. 1:

Die SAUER BIBUS Axialkolben-Verstellpumpen der Baureihe J-V in Schrägscheibenbauart sind Einheiten für den offenen Kreislauf mit verstellbarem oder geregelttem Fördervolumen. Sie wurden speziell für den Einsatz in stationären Anwendungen entwickelt.

The SAUER BIBUS variable displacement axial piston pumps, series J-V swash plate construction, are suitable for open loop circuits with adjustable or regulated delivery flow. These units are specially designed for use in industrial applications.

Le pompe variabili a pistoni assiali SAUER BIBUS serie J-V a piatto inclinato sono componenti per circuito aperto a cilindrata variabile o regolabile. Sono state specificatamente concepite per l'impiego in applicazioni industriali.

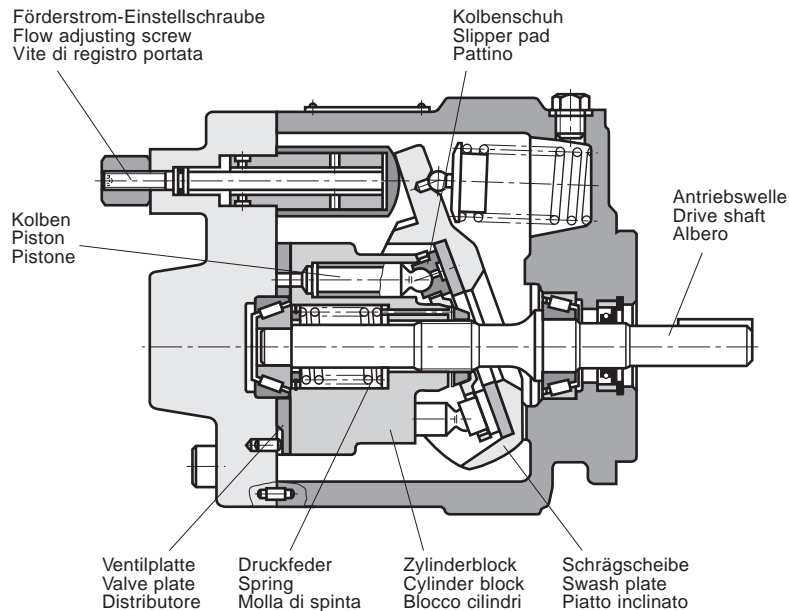
Besondere Merkmale

- extrem niedrige Geräuschwerte über den gesamten Druckbereich durch gezielte Triebwerks- und Lagerentwicklung
- ein marktgerechtes Reglerprogramm führt zu Energieersparnis durch optimale Anpassung von Druck- und Förderstrom und zu einem geringeren Kostenaufwand durch Wegfall von Ventilen in bisher ausgeführten Hydraulikkreisläufen.
- die niedrige Verlustleistung der Einheiten, insbesondere im Nullhubbetrieb, führt zu einer geringeren Ölerwärmung und damit zu kompakten, platzsparenden Behälterabmessungen
- kurze Regelzeiten und hohe Wiederholungsgenauigkeiten bei der Druck- und Förderstromregelung reduzieren Zykluszeiten von Maschinen bei gleichzeitiger Erhöhung der Zuverlässigkeit
- einfache Erstbefüllung der Einheit mit dem Betriebsmedium im betriebsbereiten, verrohrten Zustand, ohne Abbau der Leckölleitung durch zusätzlich verfügbare Verschlusschraube
- eine mechanisch einstellbare Förder volumengrenzung erlaubt die stufenlose Anpassung des Förderstroms an die Forderung einer Anwendung
- servicefreundliche Gesamtkonstruktion

Special Characteristics

- low external noise levels across the entire pressure range because of specially developed mechanism and bearing design
- a comprehensive control selection assures energy saving through optimal adjustment of pressure and delivery flow, lower unit cost because valves used in conventional hydraulic circuit designs are superfluous in this system
- low oil heat generation because of low dissipation loss, especially during dead head operation, facilitates compact spacesaving reservoir design
- fast response time and high repetition accuracy for pressure and delivery flow, reducing machine cycle times while at the same time improving reliability
- simple first filling with hydraulic medium in mounted state without dismantling any lines, because of an extra locking screw
- mechanical adjustment to allow adjustment of delivery flow to suit the application
- simple construction for ease of service

Caratteristiche specifiche

- rumorosità estremamente contenuta in tutto il campo di pressione grazie alla progettazione mirata del rotore e della supportazione
- un'esauriente gamma di controlli assicura risparmio di energia attraverso la regolazione ottimale di pressione e portata e porta a un costo di realizzazione inferiore poichè valvole utilizzate in circuiti convenzionali diventa no superflue in questo sistema
- bassa generazione di calore grazie a dissipazioni minime, specialmente in fase di compensazione; ciò porta a serbatoi più piccoli.
- tempo di risposta breve con elevata precisione nella ripetizione dei valori di pressione e portata, con conseguente riduzione del ciclo macchina e miglioramento dell'affidabilità
- facile riempimento della pompa con il fluido in condizione di tubazioni collegate senza disconnettere il drenaggio, grazie all'apposito foro con tappo di chiusura
- il limitatore meccanico di cilindrata permette una regolazione continua con adattamento alle portate richieste dall'utilizzo
- semplicità di realizzazione e facilità di manutenzione

Axialkolben-Verstellpumpen
Variable displacement axial piston pumps
Pompe variabili a pistoni assiali

Baureihe J-V
Series J-V
Serie J-V

Regel- und Verstellorgane - Control devices - Dispositivi di regolazione

Bezeichnung Description Denominazione	Typ Type Tipo	Sinnbild Symbol Simbolo	Kennlinie Characteristic Curva caratteristica
Nullhubdruckregler - mech. einstellbar Pressure compensator control - mechanical adjustment Regolatore ad annullamento di portata - registr. meccanica	A		
Nullhubdruckregler - hydr. fernsteuerbar Remote pressure compensator control - hydraulic remote control by pilot relief valve Regolatore ad annullamento di portata - pilotaggio idr. a distanza	A-RC		
Zweistufen-Nullhubdruckregler - elektr. umschaltbar Dual pressure compensator control - electrically switched Regolatore ad annullamento di portata a due stadi - a commutazione elettr.	D		
kombinierter Nullhubdruck- und Förderstromregler Combined flow and pressure compensator control Regolatore di portata combinato con annullamento di portata	SA		
Zweistufen-Nullhubdruckregler, hydr. umschaltbar, kombiniert mit Fördervolumenumschaltung Combined control pressure and displacement with system pressure Regolatore ad annullamento di portata a due stadi, commutazione idr., con cambio di cilindrata	CH		
Zweistufen-Nullhubdruckregler, elekt. umschaltbar, kombiniert mit Fördervolumenumschaltung Combined control pressure and displacement with solenoid valve Regolatore ad annullamento di portata a due stadi, commutazione elettr., con cambio di cilindrata	CJ		

Tabelle / Table / Tabella 1:

Axialkolben-Verstellpumpen

Variable displacement axial piston pumps

Pompe variabili a pistonni assiali

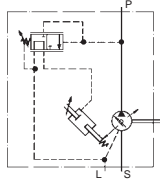
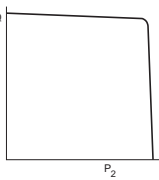
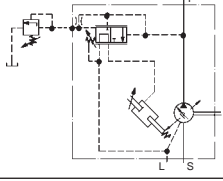
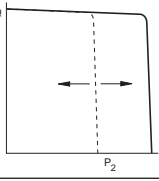
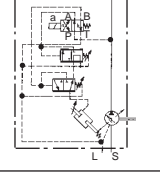
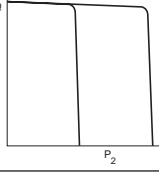
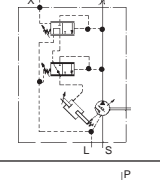
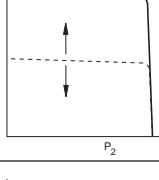
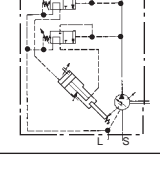
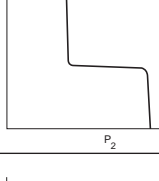
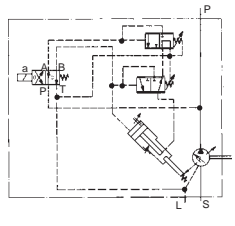
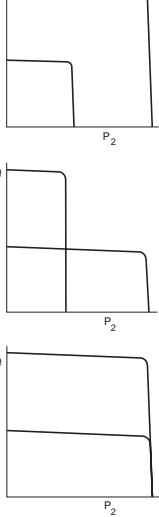
Baureihe J-V
Series J-V
Serie J-V

Regel- und Verstellorgane · Control devices · Dispositivi di regolazione

Bezeichnung Description Denominazione	Typ Type Tipo	Sinnbild Symbol Simbolo	Kennlinie Characteristic Curva caratteristica
<p>Leistungsregler - mechanisch einstellbar - kombinierbar mit Regler A, A-RC*, SA</p> <p>Horse power control - mechanical adjustment - possible combinations with control A, A-RC*, SA</p> <p>Regolatore a potenza costante - registrazione meccanica - possibili combinazioni con i regolatori A, A-RC*, SA</p> <p>* externe Düse 0,8 mm erforderlich * external orifice 0,8 mm neccess * è necessario un ugelio 0,8 mm esterno</p>	CP		

Tabelle / Table / Tabella 1:

Bei der Bestellung eines Leistungsreglers für die Pumpenbaureihe J-V bitte beachten:

- nur rechtsdrehende Ausführung
- nur radiale Anschlüsse möglich
- keine Durchtriebspumpe möglich
- Leistungsangabe bei der Bestellung angeben*
- fixe Drehzahl bei der Bestellung angeben*

* diese an der Pumpe eingestellten Werte können nachträglich durch SAUER BIBUS verändert werden.

For orders of pumps series J-V with horse power control please note following details:

- only clockwise rotating
- only radial ports
- no through drive pumps
- necessary for orders: horse power*
- necessary for orders: rpm*

* these datas can be changed after delivery only by SAUER BIBUS

Per ordini di pompe serie J-V con regolatore a potenza costante considerare i seguenti dettagli:

- solo rotazione destra
- solo attacchi radiali
- presa -di-forza post. non disponibile
- specificare nell'ordine: potenza*
- specificare nell'ordine: velocità g/1*

* questi dati possono essere cambiati dopo la consegna solo dalla SAUER BIBUS

Aufgenommene Pumpenleistung (weitere Varianten auf Anfrage):

Input pump power (other variants on demand):

Grandezze disponibili (altre varianti a richiesta):

Leistung / Power / Potenza 1.500 min ⁻¹	4 kW	5,5 kW	7,5 kW	11 kW	15 kW	18,5 kW	22 kW	30 kW
J-V 23	•	•	•					
J-V 38		•	•	•	•			
J-V 50		•	•	•	•	•		
J-V 70			•	•	•	•	•	•

Tabelle / Table / Tabella

Axialkolben-Verstellpumpen
Variable displacement axial piston pumps
Pompe variabili a pistonni assiali

Baureihe J-V
Series J-V
Serie J-V

Kenngößen · Operating data · Dati caratteristici

Benennung Description Descrizione	Formelz. Symbol Simbolo	Einheit Unit Unità di mis.	Baugröße · Size · Grandezza					
			8	15	23	38	50	70
Befestigungsart; stirns. Flanschbefestigung Type of attachment Flangia di fissaggio ant.	-	-	ISO 3019/2 2-Loch fori	ISO 3019/1 2-Loch fori			ISO 3019/1 2/4-Loch fori	
Geometrisches Fördervolumen Displacement Cilindrata	V _g	cm ³ /U	8,0	14,8	23,0	37,7	51,6	69,8
Geometr. Förderstrom · Outlet flow · Portata a n=1500 min ⁻¹ - mech. Einstellbereich · Adjustment range · Campo di regolazione - A, A-RC, SA, D Regler · control · regolatore - CH, CJ Regler · control · regolatore	q _{v2} q _{v2, I} q _{v2, II}	l/min	3,3...12,0 - -	4,3...22,2 7,1...22,2 0,9...10,8	8,9...34,5 11,0...34,5 2,6...18,8	23,0...56,6 26,7...56,6 6,6...33,3	0...77,4 - -	16,9...104,7 35,0...104,7 2,5...52,5
Drehrichtung, Gewicht Sense of rotation, Weight Senso di rotazione, peso	-	-	siehe Tabelle 3 see table 3 vedi tabella 3					
Drehzahlbereich Range of speeds Gamma di velocità	n _{min} n _{max}	min ⁻¹	500 1800* *höhere Drehzahlen auf Anfrage · higher rpm on demand · numeri di giri più alti: a richiesta					
Eingangsdruckbereich Inlet pressure range Campo di pressione in asp.	p _{1, min} p _{1, max} p _{1, n}	bar _{abs}	0,83 2,0 0,95...1,1					
Leckstromdruckbereich Case pressure range Campo di pressione drenaggio	p _{Vd, max}	bar	0,35 für Dauerbetrieb, 1,0 kurzzeitig 0,35 for cont. operation, 1,0 momentary 0,35 in esercizio continuo, 1,0 intermittenti					
Ausgangsdruckbereich (DIN 24312) Outlet pressure range (DIN 24312) Campo press. in mandata (DIN 24312) - Nenndruck · nominal press. · Press. nominale - Höchstdruck · peak pressure · Pressione di punta	p _{2, n} p _{2, p}	bar	70 105	210 315*)	250 315*)	210 315*)		
Viskositätsbereich am Eingang Viscosity range Gamma di viscosità	v _{1, min} v _{1, max}	mm ² /s	15 400					
Druckflüssigk.temperaturber. am Eingang Hydraulic fluid temperature range Gamma di temperatura del fluido idr.	θ _{1, f. min} θ _{1, f. max}	°C	0 60					
Reinheitsgrad der Druckflüssigkeit Fluid cleanliness Grado di pulizia del fluido	-	-	18/14 nach CETOP RP 70 H oder 9 nach NAS 1638 und besser, insbesondere bei hohen Belastungen und Lebensdauerforderungen 18/14 to CETOP RP 70 H or 9 to NAS 1638 or better, especially at high loads and high life expectancy requirements 18/14 secondo CETOP RP 70 H oppure 9 secondo NAS 1638 o migliori, in particolare con carichi gravosi o se viene richiesta una durata elevata.					
Druckflüssigkeit Hydraulic fluid Fluido idraulico	-	-	auf Mineralölbasis nach DIN 51524 u.DIN 51525, andere Flüssigkeiten auf Anfrage, bei Bedarf bitte Druckflüssigkeitsempfehlung anfordern · For mineral oil base DIN 51524 and DIN 51525, other fluids on request, please ask for hydraulic fluid recommendations if required · a base minerale secondo DIN 51524 e DIN 51525, altri fluidi a richiesta, in caso di bisogno preghiamo esigere fluidi consigliati; Viskosität · viscosity · viscosità: v _{min} = 7 mm ² /s v _{empt.} = 12...54 mm ² /s Betriebsviskosität empfohlen · rated viscosity · Viscosità di esercizio consigliata v _{max} = 800 mm ² /s kurz. bei Start, wenige Sek. · intermittent, cold start · Viscosità di avviamento, per pochi secondi					
Filterung · Filtering · Filtrazione - saugseitig · suction · in aspirazione - rücklaufseitig · return · sul ritorno	-	µm	150 25 absolut / absolute / assoluti					
Füllmenge für Erstbefüllung Oil volumes for first filling Olio di primo riempimento	-	l	0,3	0,5	0,5	0,9	2,0	2,0

*10% eines Zyklus, max. 6 sek. / 10% of one cycle, max. 6 sec. / 10% di ciclo, massimo 6 sec. **Tabelle / Table / Tabella 2:**

Axialkolben-Verstellpumpen
Variable displacement axial piston pumps
Pompe variabili a pistoni assiali

Baureihe J-V
Series J-V
Serie J-V

Drehrichtung und Masse · Sense of rotation and weight · Senso di rotazione e peso

Baugröße Size Grandezza	Lage d. Arbeits- anschlüsse Port Position Posizione delle bocche	Drehrichtung: R=rechtsdrehend · Sense of rotation: R=clockwise · Senso di rotazione: R=destro L=linksdrehend L=counter clock. L=sinistro											
		Masse m [kg]				Weight m [kg]				Peso m [kg]			
		bei Verwendung des Reglers · for use with controls · con l'utilizzo dei regolatori											
		A		A-RC		SA		D		CH		CJ	
8	radial	R	9,0	-	-	-	-	-	-	-	-	-	-
15	radial	R (L)	13,0	R (L)	14,5	R (L)	13,7	R	16,3	R	16,1	R	17,8
	axial	R (L)	11,3	R (L)	12,8	R (L)	12,0	-	-	-	-	-	-
23	radial	R (L)	21,5	R (L)	23,0	R (L)	22,2	R	24,8	R	23,4	R	25,1
	axial	R (L)	18,4	R (L)	20,0	R (L)	19,1	-	-	-	-	-	-
38	radial	R (L)	23,0	R (L)	25,7	R (L)	25,0	R	27,5	R	26,0	R	27,7
	axial	R (L)	21,4	R (L)	23,0	R (L)	22,1	-	-	-	-	-	-
50	radial	R (L)	50,0	R (L)	52,1	R (L)	52,8	-	-	-	-	-	-
70	radial	R (L)	55,0	R (L)	57,1	R (L)	58,6	-	-	R	59,3	-	-

Tabelle / Table / Tabella 3:

Nullhubdruckeinstellbereich · Adjustable pressure range · Campo di registrazione della press. di azz.

Regler Controls Regolatore		Nullhubdruckeinstellbereich p_2 Adjustable pressure range p_2 Campo di registrazione press. di azz. p_2 bar					
		Baugröße · Size · Grandezza					
		8	15	23	38	50	70
A	A1	8 ... 70			15 ... 70		
	A2	-	15 ... 140				
	A3	-	35 ... 210				
	A4	-	-	35 ... 250		-	
A-RC	A3-RC	-	15...210	-		20 ... 210	
	A4-RC	-	-	15 ... 250		-	
SA	SA1*	15 ... 70					-
	SA2*	15 ... 140					-
	SA3*	35 ... 210					-
	SA4*	-	-	35 ... 250		-	
D	D1*	15 ... 70			-		
	D2*	15 ... 140			-		
	D*1	15 ... 70			-		
	D*2	15 ... 140			-		
	D*3	35 ... 210			-		
	D*4	-	-	35 ... 250		-	
	D11	-	15...70	je Stufe · each stage · ogni stadio			-
Regler Controls Regolatore		Nullhubdruckeinstellbereich p_2 Adjustable pressure range p_2 Campo di registrazione press. di azz. p_2 bar					
		Baugröße · Size · Grandezza					
		8	15	23	38	50	70
CH	C1*H	-	25 ... 70			-	15...70
	C2*H	-	25 ... 140			-	15...140
	C*1H	-	25 ... 70			-	15...70
	C*2H	-	25 ... 140			-	15...140
	C*3H	-	35 ... 210			-	35...210
	C*4H	-	-	35 ... 250		-	
CJ	C11H	-	15...70	je Stufe · each stage · ogni stadio			-
	C1*J	-	15 ... 70			-	
	C2*J	-	15 ... 140			-	
	C*1J	-	15 ... 70			-	
CP	C*2J	-	15 ... 140			-	
	C*3J	-	35 ... 210			-	
	C*4J	-	-	35 ... 250		-	
	CP	-	-	15 ... 250		20...210	

Tabelle / Table / Tabella 4:

Axialkolben-Verstellpumpen

Variable displacement axial piston pumps

Pompe variabili a pistonni assiali

Baureihe J-V

Series J-V

Serie J-V

Typenschlüssel bei Verwendung von · Model code · Chiave di ordinazione con l'utilizzo del

Regler A · Control A · Regolatore A

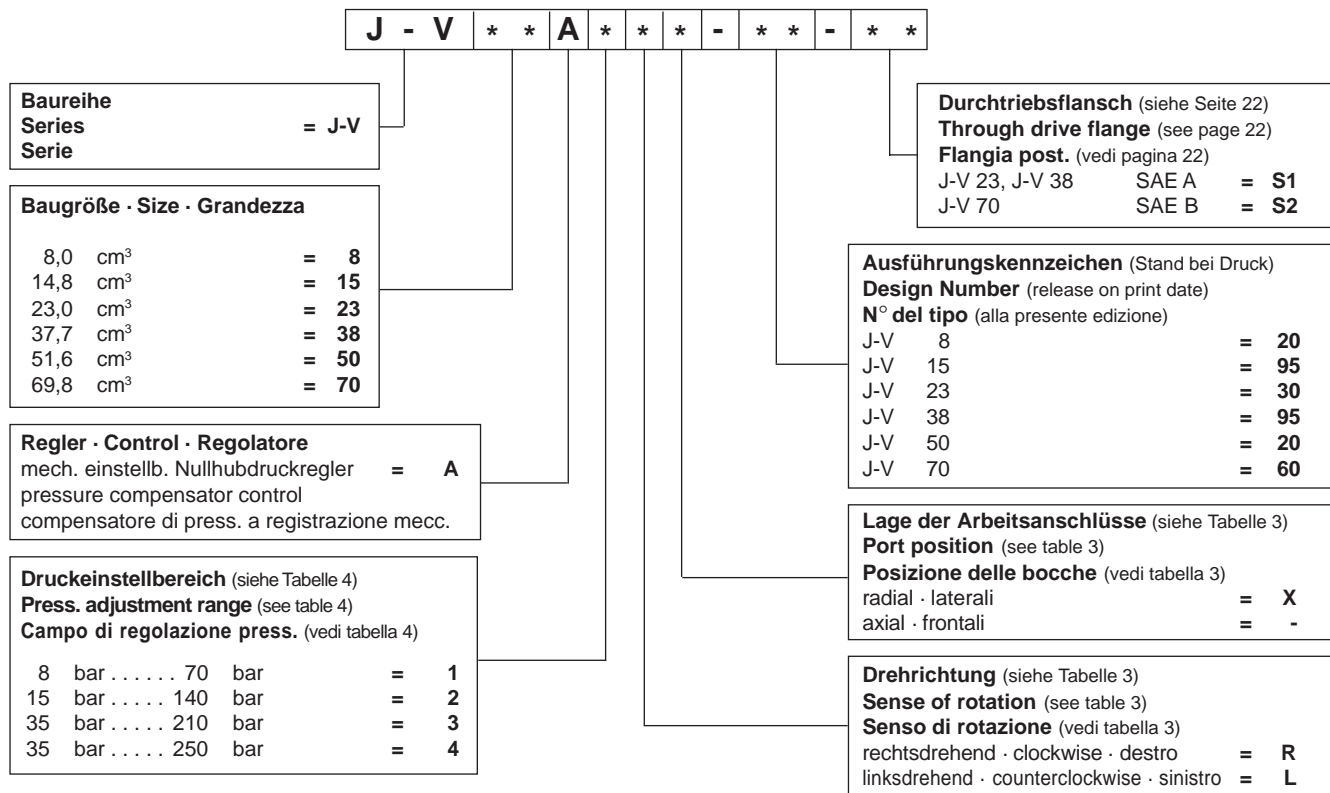

Regler A-RC · Control A-RC · Regolatore A-RC

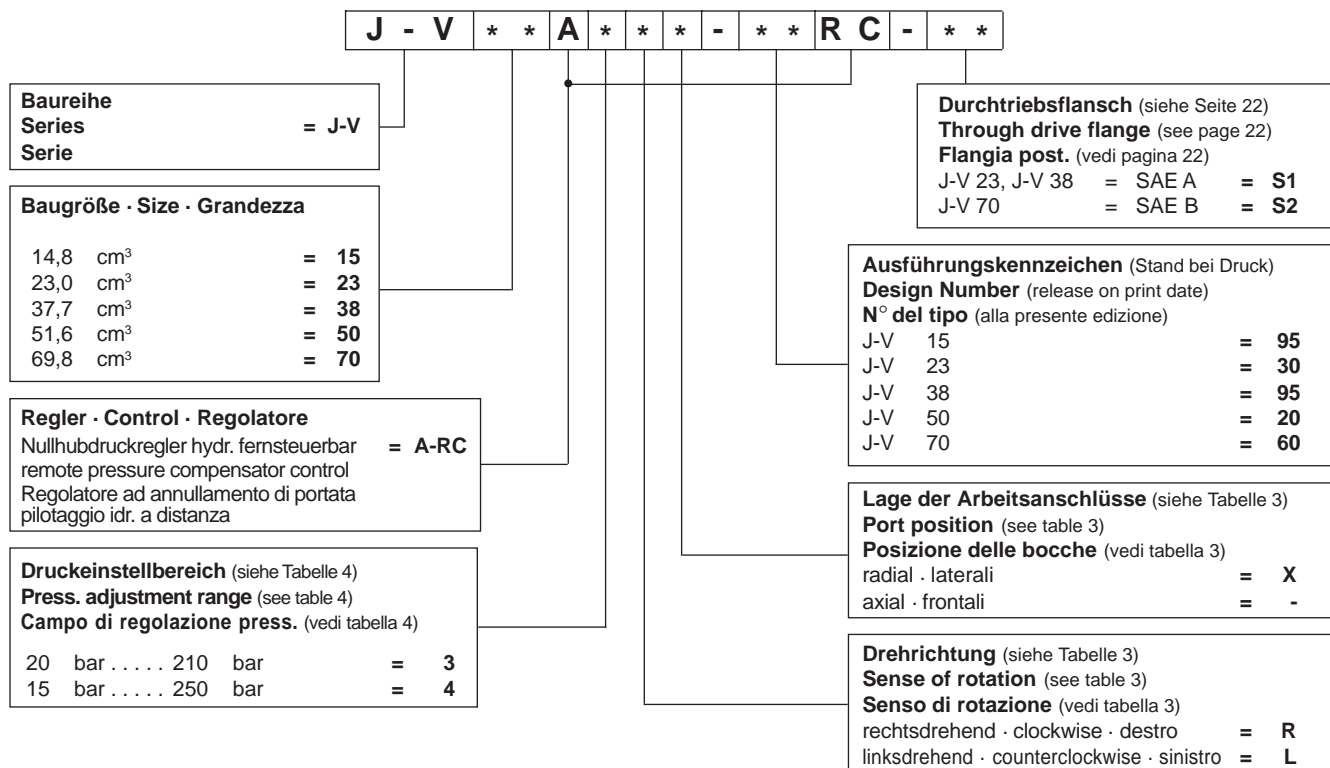

Axialkolben-Verstellpumpen

Variable displacement axial piston pumps

Pompe variabili a pistonni assiali

Baureihe J-V

Series J-V

Serie J-V

Typenschlüssel bei Verwendung von · Model code · Chiave di ordinazione con l'utilizzo del

Regler SA · Control SA · Regolatore SA

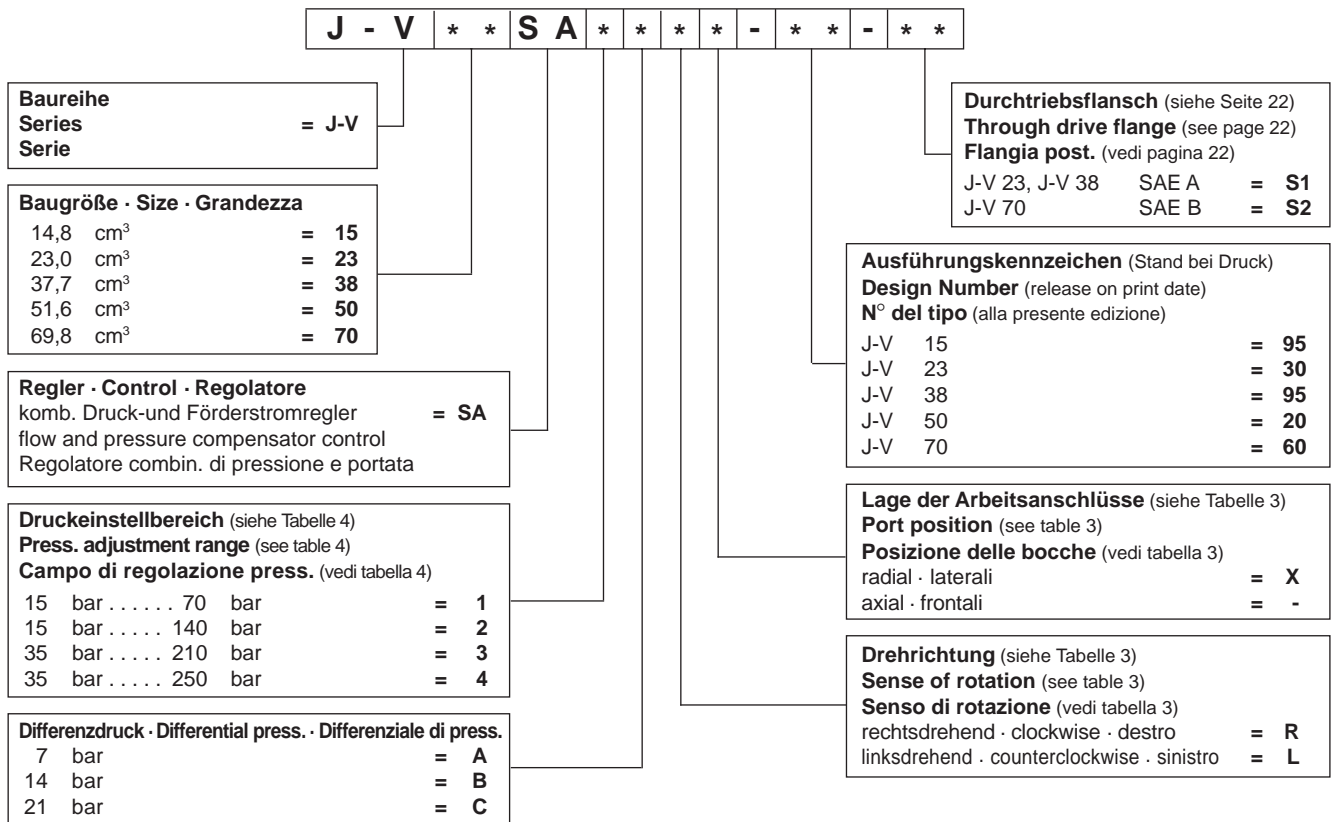

Regler D · Control D · Regolatore D

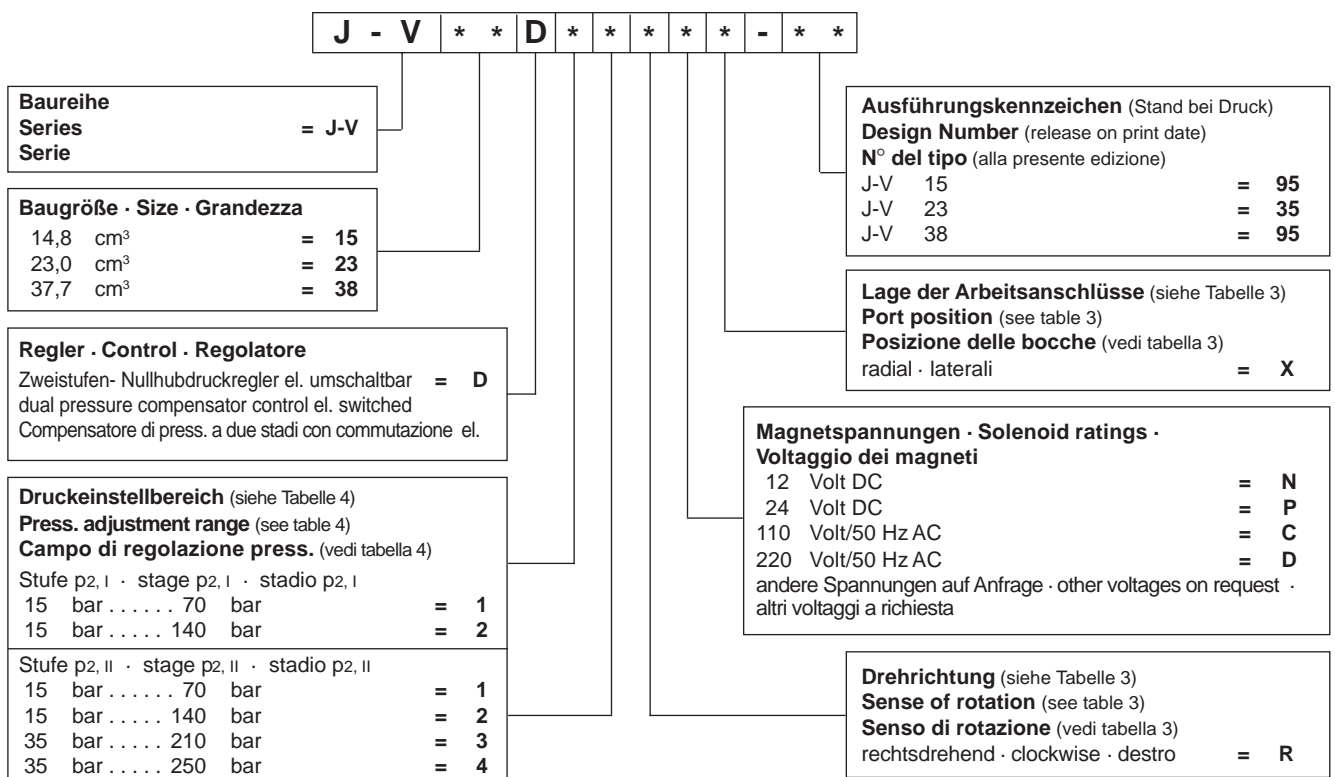

Axialkolben-Verstellpumpen

Variable displacement axial piston pumps

Pompe variabili a pistoni assiali

Baureihe J-V

Series J-V

Serie J-V

Typenschlüssel bei Verwendung von · Model code · Chiave di ordinazione con l'utilizzo del

Regler CH · Control CH · Regolatore CH

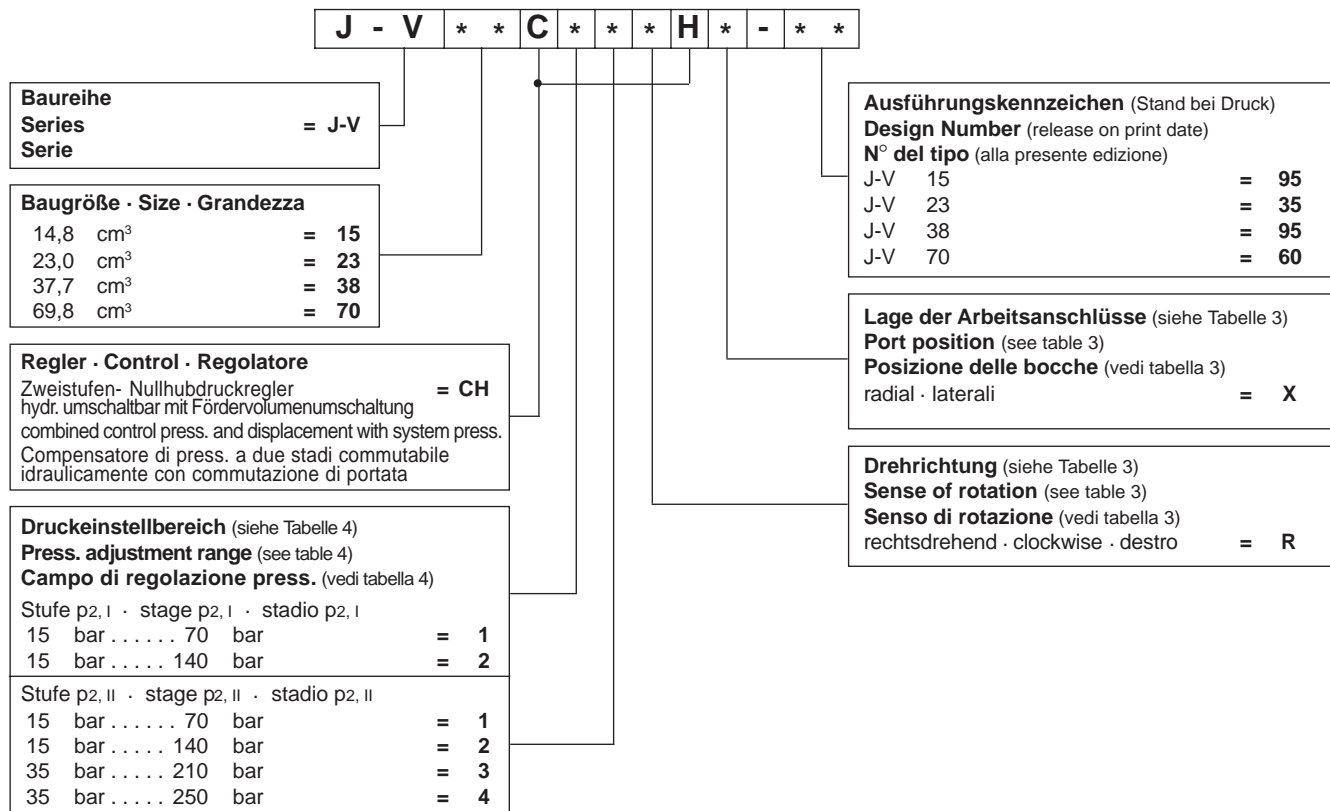

Regler CJ · Control CJ · Regolatore CJ

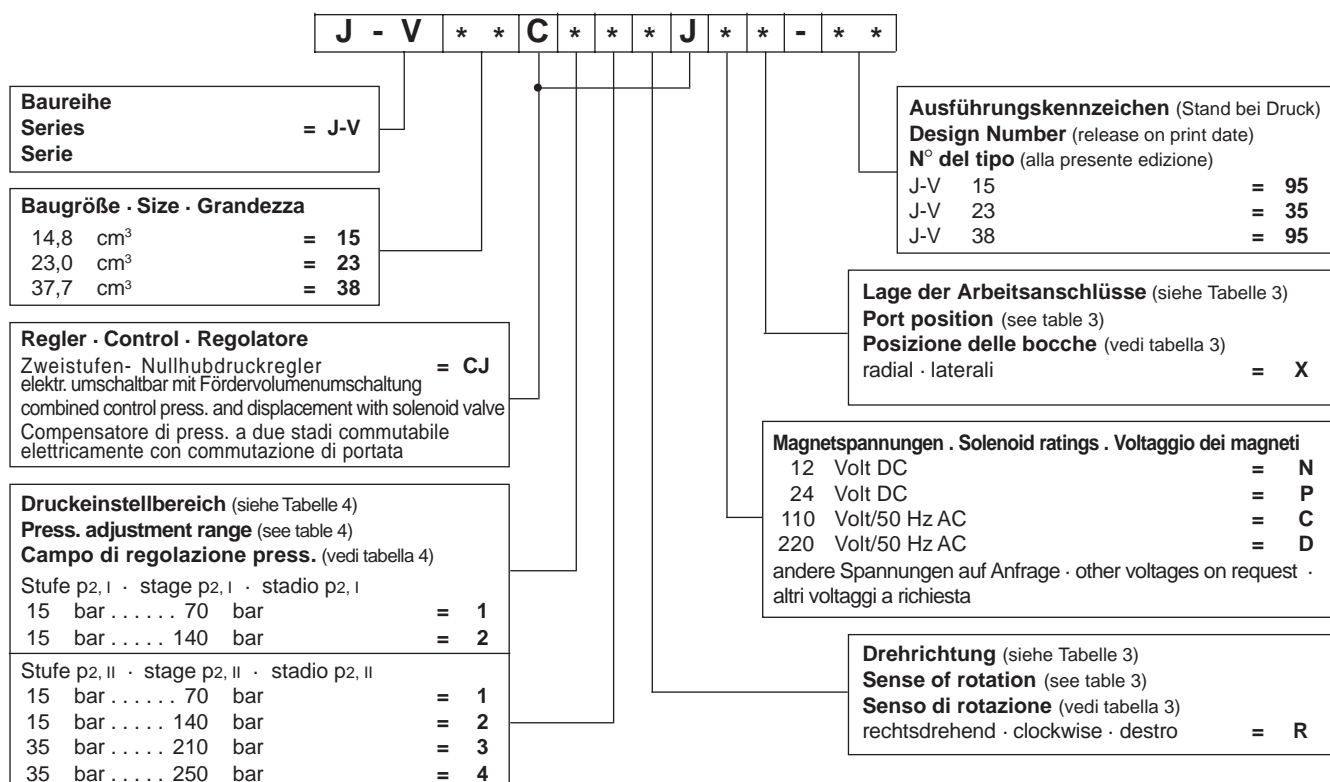

Axialkolben-Verstellpumpen
Variable displacement axial piston pumps
Pompe variabili a pistoni assiali

Baureihe J-V
Series J-V
Serie J-V

Typenschlüssel bei Verwendung von · Model code · Chiave di ordinazione con l'utilizzo del
Regler CP · Control CP · Regolatore CP

Der Bestellcode für die leistungs-
 geregelte Pumpe wird an den bestehen-
 den Typenschlüssel angehängt.

The order-code for horse power control
 limited pumps is added to the standard
 code:

La descrittiva per il regolatore a potenza
 costante è da aggiungere alla descrittiva
 standard:

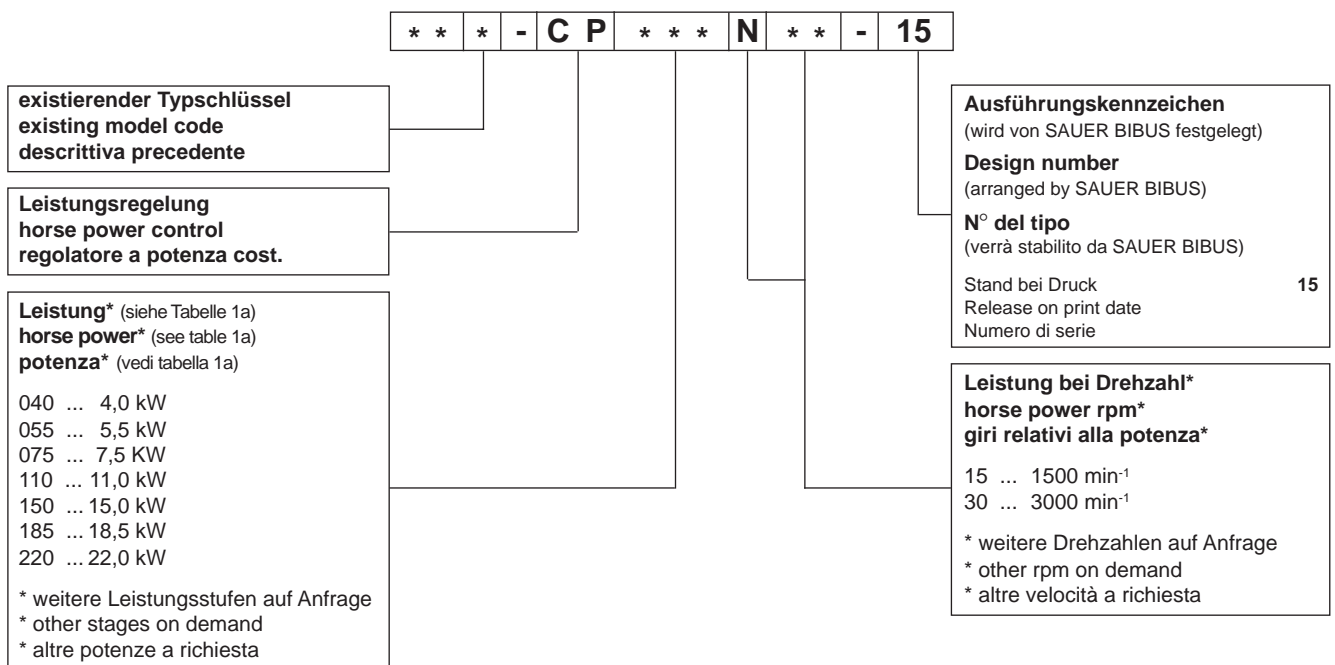

Bestellbeispiel für eine Pumpe J-V mit
 38 cm³, fernsteuerbarer Nullhubdruck-
 regler bis 210 bar, rechtsdrehend, mit
 Leistungsregler 7,5 kW bei 1.500 min⁻¹.

Example for a pump J-V with 38 cm³,
 remote pressure compensator control to
 210 bar, rotating clockwise, horse power
 control 7,5 kW with 1.500 min⁻¹.

Esempio di una pompa J-V da 38 cm³,
 compensatore di press. fino a 210 bar,
 rotazione destra, regolatore a potenza
 cost. 7,5 kW a 1.500 giri/1.

J	-	V	38	A	3	R	X	-	95	R	C	-	C	P	075	N	15	-	15
---	---	---	----	---	---	---	---	---	----	---	---	---	---	---	-----	---	----	---	----

Axialkolben-Verstellpumpen
Variable displacement axial piston pumps
Pompe variabili a pistoni assiali

Baureihe J-V
Series J-V
Serie J-V

Kennlinien · Characteristics · Curve caratteristiche

Meßbedingungen: n=1500 min⁻¹
 θ_{1,f}=50°C, Mineralöl ISO VG 32

Measuring conditions: n=1500 min⁻¹
 θ_{1,f}=50°C, mineral oil ISO VG 32

Condizioni di misurazione: n=1500 min⁻¹
 θ_{1,f}=50°C, olio minerale ISO VG 32

Dynamisches Verhalten des Nullhubdruckreglers A · Dynamic performance of control A · Prestazione dinamica del compensatore A

Baugröße Size Grandezza	Abregelzeit Response time Tempo di risposta t ₁ [s]	Aufregelzeit Response time Tempo di risposta t ₂ [s]	Druckspitze Pressure peak Picco di press. p _s [bar]
8	0,04 ... 0,05	0,05 ... 0,07	10 ... 30
15	0,04 ... 0,05	0,05 ... 0,07	25 ... 40
23	0,05 ... 0,06	0,05 ... 0,07	35 ... 70
38	0,05 ... 0,06	0,05 ... 0,07	55 ... 90
50	0,06 ... 0,09	0,06 ... 0,09	60 ... 100
70	0,06 ... 0,09	0,06 ... 0,09	65 ... 100

Tabelle / Table / Tabella 5:



Bild / Fig. 2:



Bild / Fig. 3:

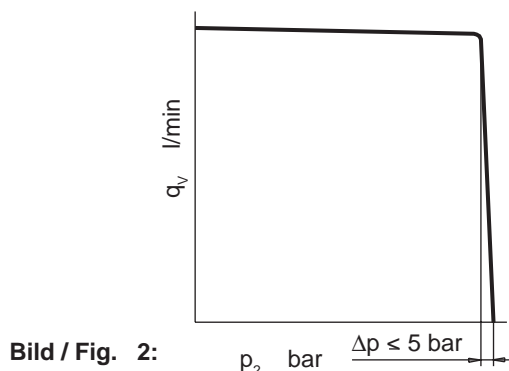

Bild / Fig. 4:

Geräuschmessungen (Kennlinie L_p-p₂) · Noise level (characteristic L_p-p₂) · Livello di rumorosità (curva L_p-p₂)

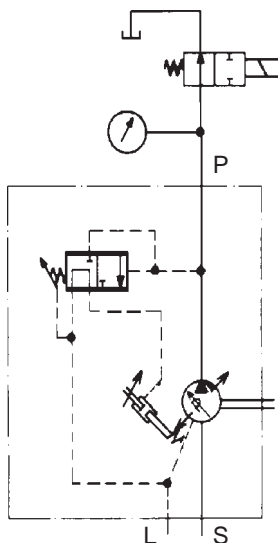
gemessen im Schallmeßraum, Meßabstand 1m · measured in a sound measuring room, distance 1m · Misurato in camera anecoica, alla distanza di 1m

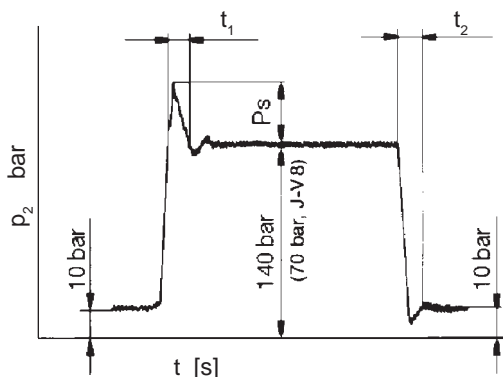

Bild / Fig. 5: Baugröße · Model · Grandezza J-V 8



Bild / Fig. 6: Baugröße · Model · Grandezza J-V 15

Axialkolben-Verstellpumpen
Variable displacement axial piston pumps
Pompe variabili a pistoni assiali

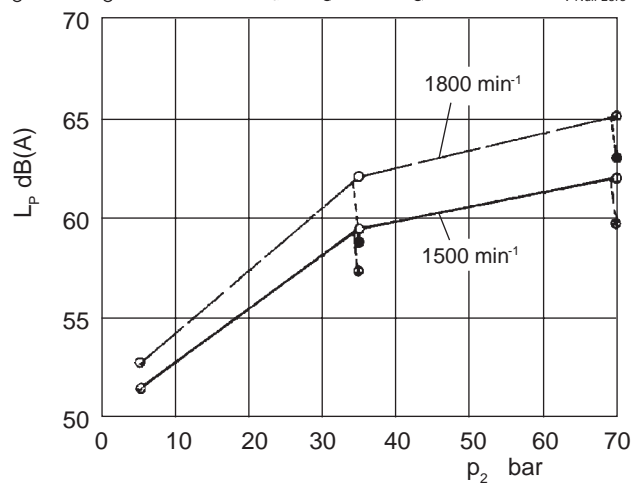
Baureihe J-V
Series J-V
Serie J-V

Geräuschmessungen (Fortsetzung) · Noise level (contd.) · Livello di rumorosità (seguito)

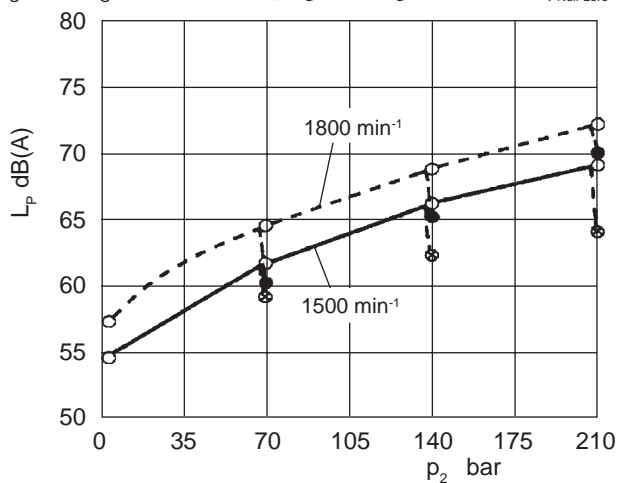

Bild / Fig. 7: Baugröße · Model · Grandezza J-V23



Bild / Fig. 8: Baugröße · Model · Grandezza J-V38

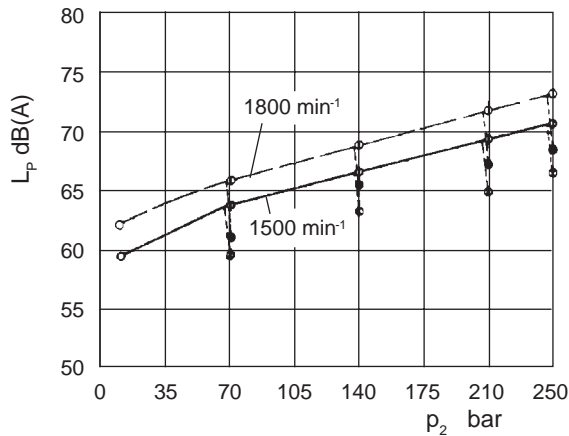

Bild / Fig. 9: Baugröße · Model · Grandezza J-V50

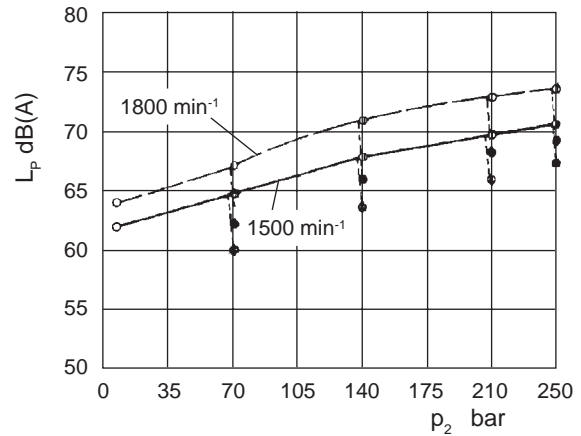

Bild / Fig. 10: Baugröße · Model · Grandezza J-V70

Wirkungsgrad, Förderstrom, Leistung (Kennlinie η , q_{ve} , P - p_2)
Performance characteristic (eff. η , q_{ve} , input power P - p_2)
Curve caratt. (Rendimento η , Portata q_{ve} , Potenza in entrata P - p_2)

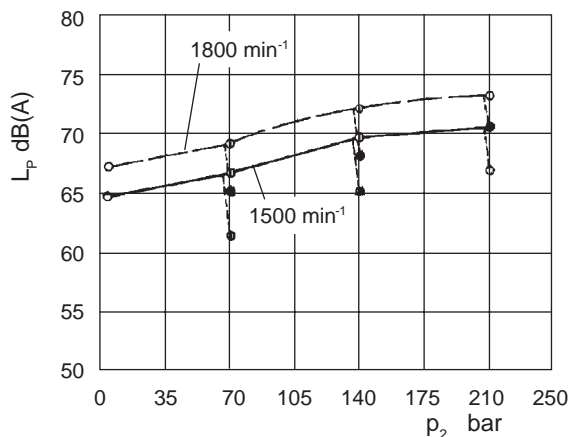
V_g = Schluckvolumen cm^3 · capacity · cilindrata

p_{HD} = Hochdruck bar · high pressure · alta pressione

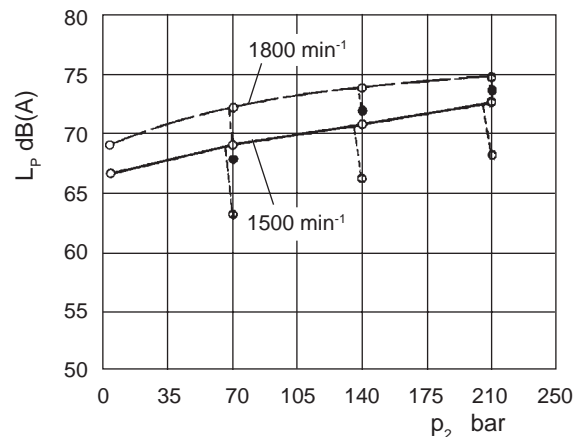
p_{ND} = Niederdruck bar · low pressure · bassa pressione

Δp = $p_{HD} - p_{ND}$ bar (Systemdruck) · system pressure · condizione del sistema

n = Drehzahl min^{-1} · drive speed · velocità di rotazione

η_v = volumetrischer Wirkungsgrad · volumetric efficiency · rendimento volumetrico

η_{mh} = mechanisch - hydraulischer Wirkungsgrad · mechanical-hydraulically efficiency · rendimento mecc.-idraulico

η_t = Gesamtwirkungsgrad · overall efficiency · rendimento totale

Axialkolben-Verstellpumpen
Variable displacement axial piston pumps
Pompe variabili a pistoni assiali

Baureihe J-V
Series J-V
Serie J-V

Wirkungsgrad, Förderstrom, Leistung (Fortsetzung) · Performance characteristic (contd.) ·
Rendimento, portata, potenza (seguito)



Bild / Fig. 11: Baugröße · Model · Grandezza J-V8 A



Bild / Fig. 12: Baugröße · Model · Grandezza J-V15 A
 SA
 A-RC
 D

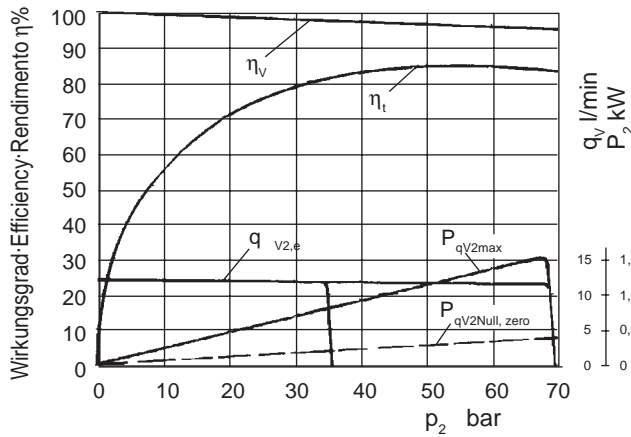

Bild / Fig. 13: Baugröße · Model · Grandezza J-V15 CH

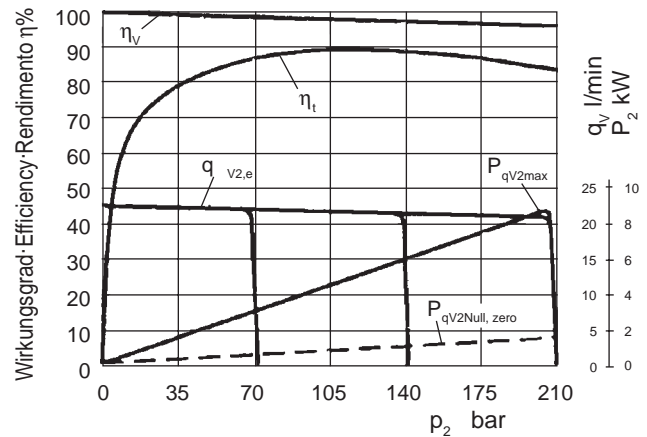

Bild / Fig. 14: Baugröße · Model · Grandezza J-V15CJ

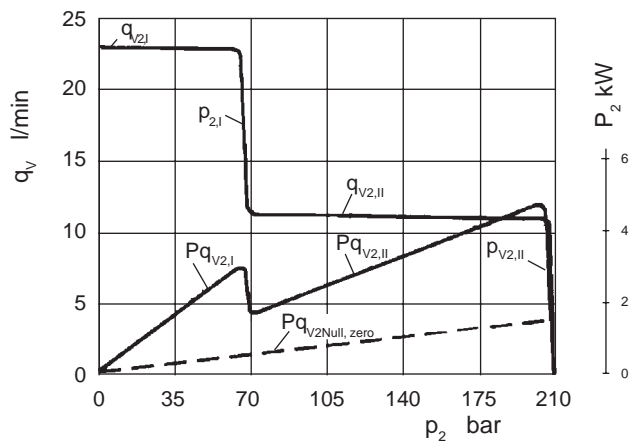

Bild / Fig. 15: Baugröße · Model · Grandezza J-V23 A
 SA
 A-RC
 D

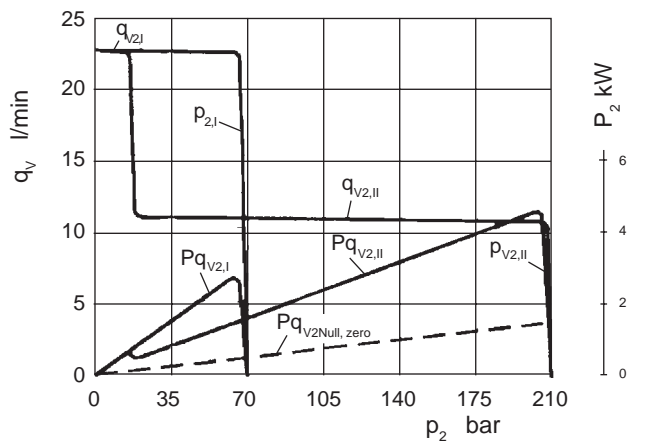

Bild / Fig. 16: Baugröße · Model · Grandezza J-V23CH

Axialkolben-Verstellpumpen
Variable displacement axial piston pumps
Pompe variabili a pistoni assiali

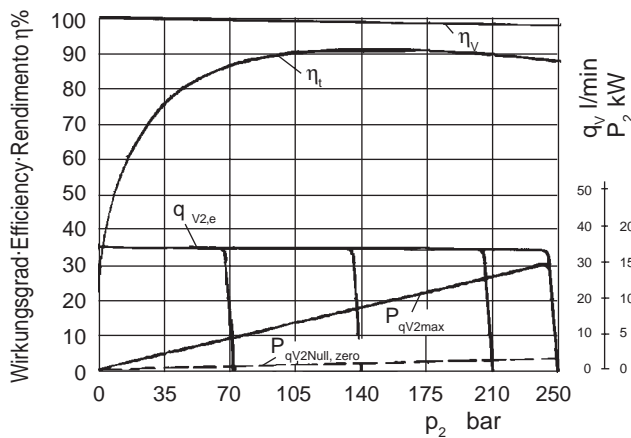
Baureihe J-V
Series J-V
Serie J-V

Wirkungsgrad, Förderstrom, Leistung (Fortsetzung) · Performance characteristic (contd.) ·
Rendimento, portata, potenza (seguito)

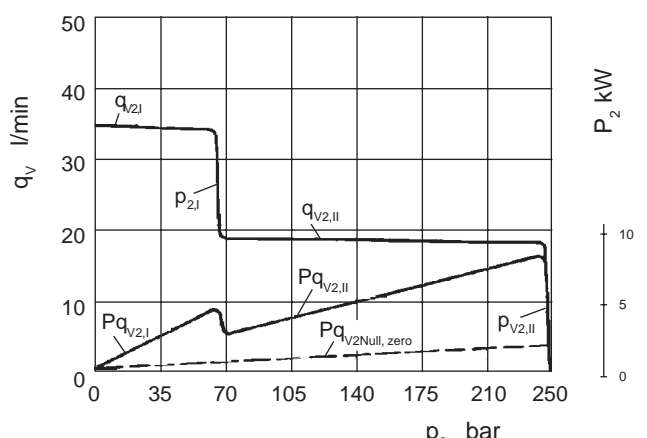

Bild / Fig. 17: Baugröße · Model · Grandezza J-V23 CJ



Bild / Fig. 18: Baugröße · Model · Grandezza J-V38 A
 SA
 A-RC
 D

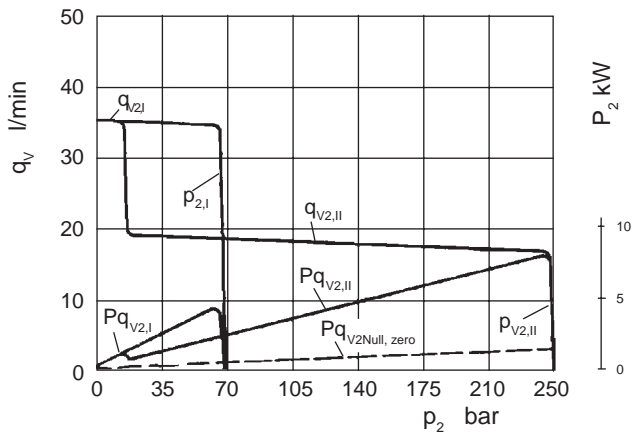

Bild / Fig. 19: Baugröße · Model · Grandezza J-V38 CH

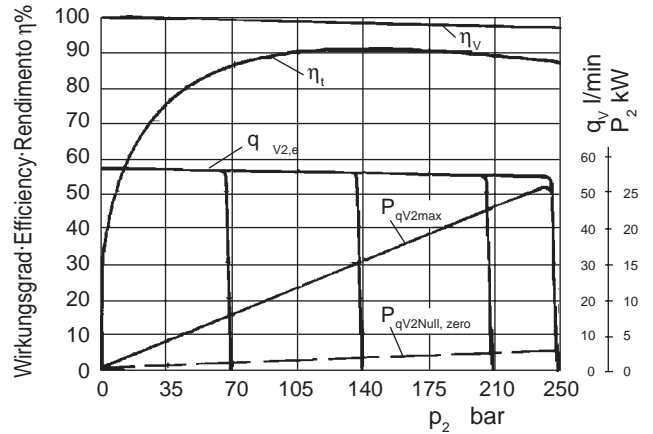

Bild / Fig. 20: Baugröße · Model · Grandezza J-V38CJ

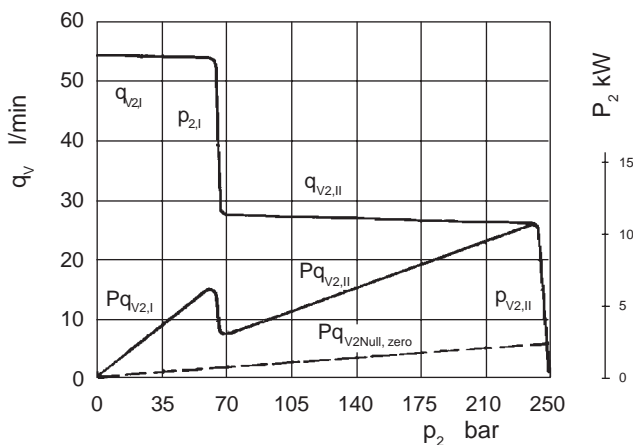

Bild / Fig. 21: Baugröße · Model · Grandezza J-V50 A
 SA
 A-RC

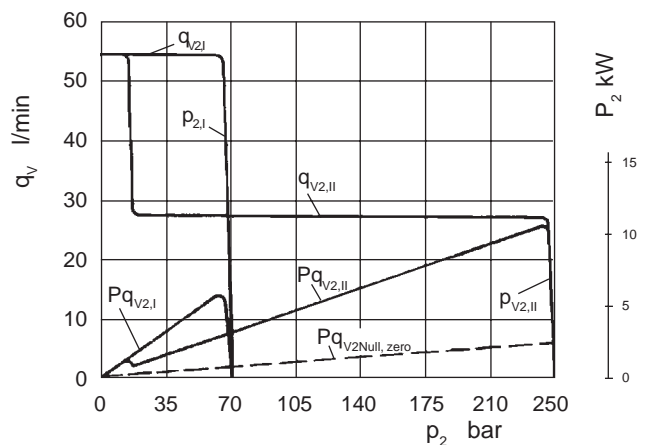

Bild / Fig. 22: Baugröße · Model · Grandezza J-V70A
 SA
 A-RC

Axialkolben-Verstellpumpen
Variable displacement axial piston pumps
Pompe variabili a pistoni assiali

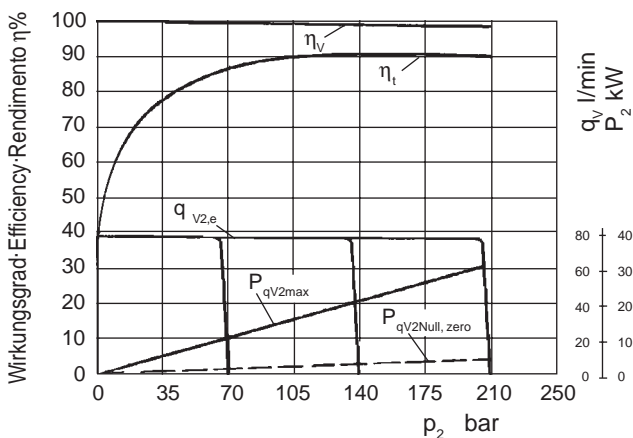
Baureihe J-V
Series J-V
Serie J-V

Externer Leckstrom ($q_{vd} - p_2$) · External leakage flow ($q_{vd} - p_2$) · Drenaggio esterno ($q_{vd} - p_2$)

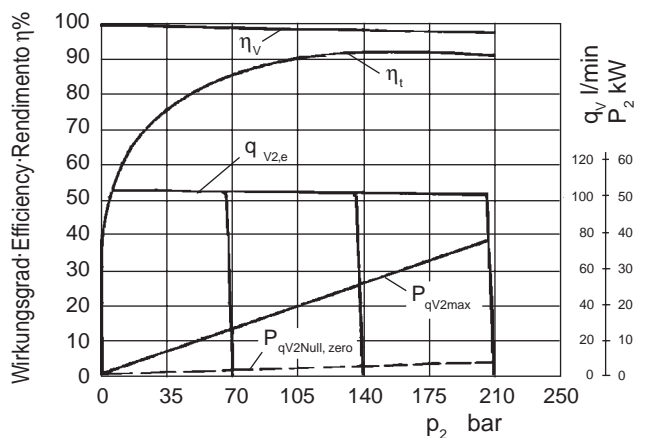

Bild / Fig. 23: Baugröße · Model · Grandezza J-V8



Bild / Fig. 24: Baugröße · Model · Grandezza J-V15

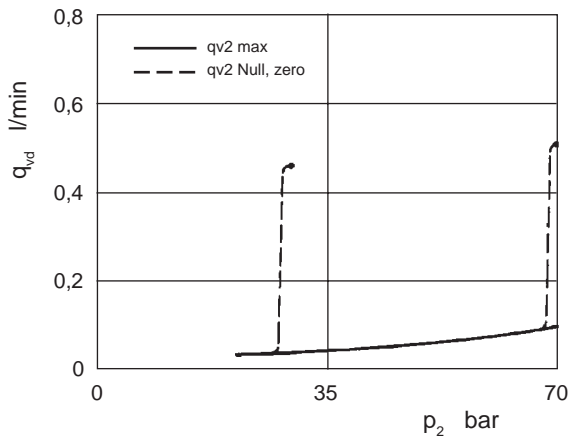

Bild / Fig. 25: Baugröße · Model · Grandezza J-V23

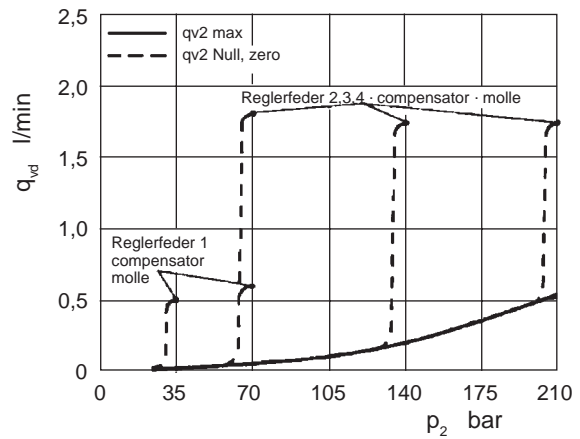

Bild / Fig. 26: Baugröße · Model · Grandezza J-V38

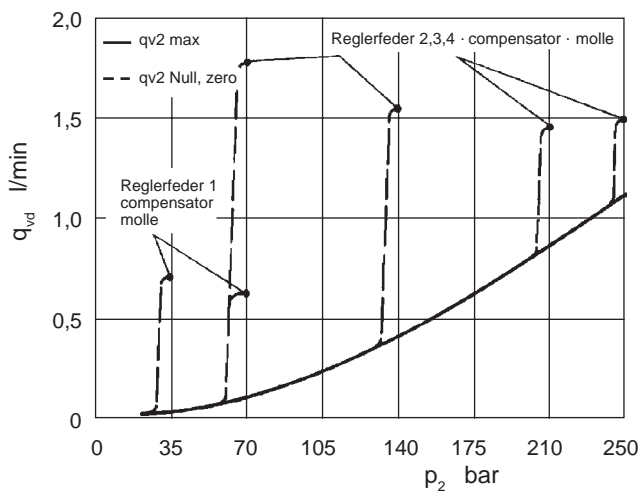

Bild / Fig. 27: Baugröße · Model · Grandezza J-V50

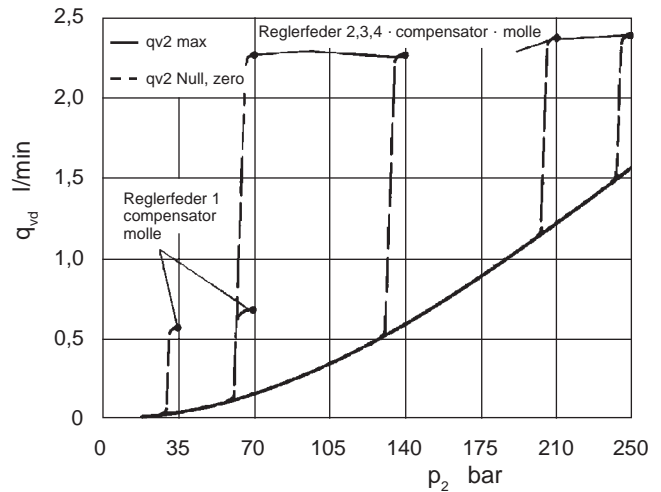

Bild / Fig. 28: Baugröße · Model · Grandezza J-V70

Axialkolben-Verstellpumpen
Variable displacement axial piston pumps
Pompe variabili a pistoni assiali

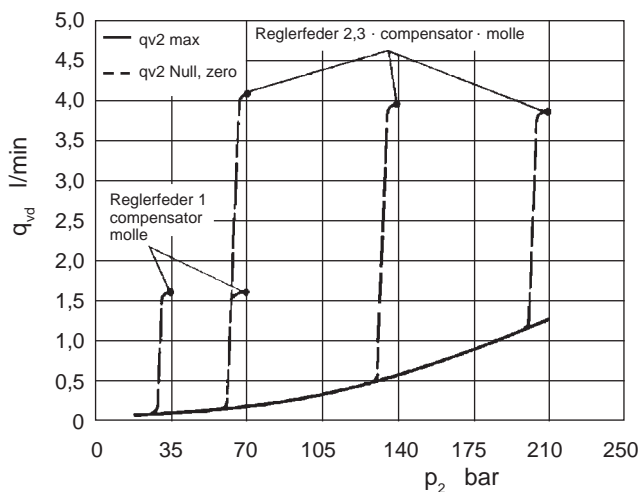
Baureihe J-V
Series J-V
Serie J-V

Nullhubleistung ($P_{q_{vNull}} - p_2$) · Dead head horsepower characteristic ($P_{q_{vNull}} - p_2$) ·
Potenza dispersa in compensazione ($P_{q_{vNull}} - p_2$)

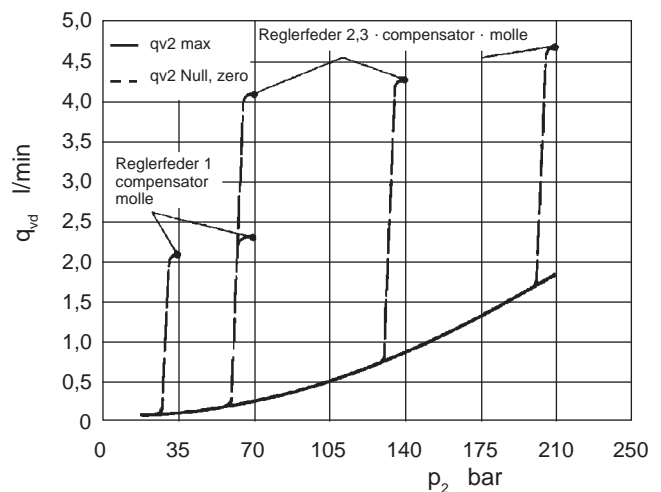

Bild / Fig. 29: Baugröße · Model · Grandezza J-V8



Bild / Fig. 30: Baugröße · Model · Grandezza J-V15

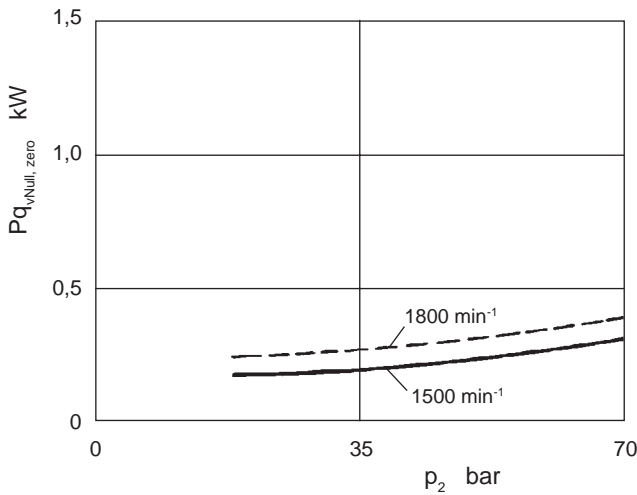

Bild / Fig. 31: Baugröße · Model · Grandezza J-V23

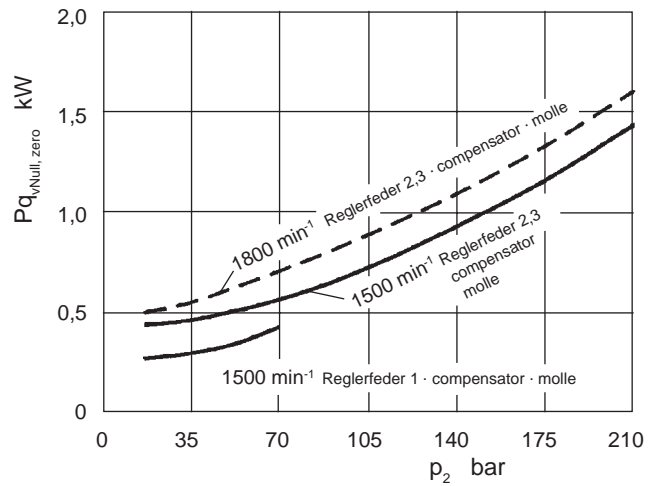

Bild / Fig. 32: Baugröße · Model · Grandezza J-V38

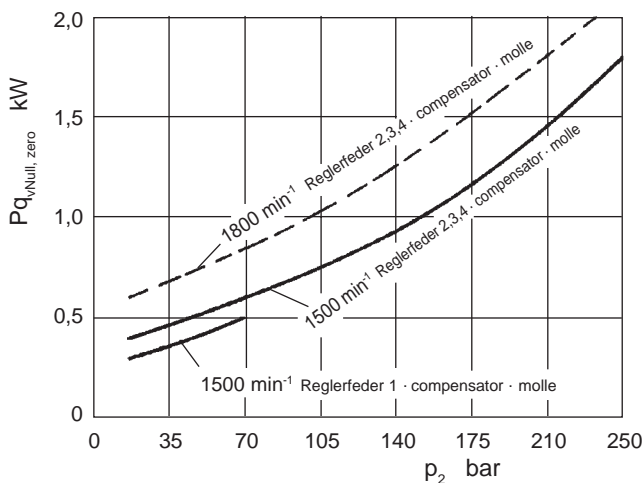

Bild / Fig. 33: Baugröße · Model · Grandezza J-V50

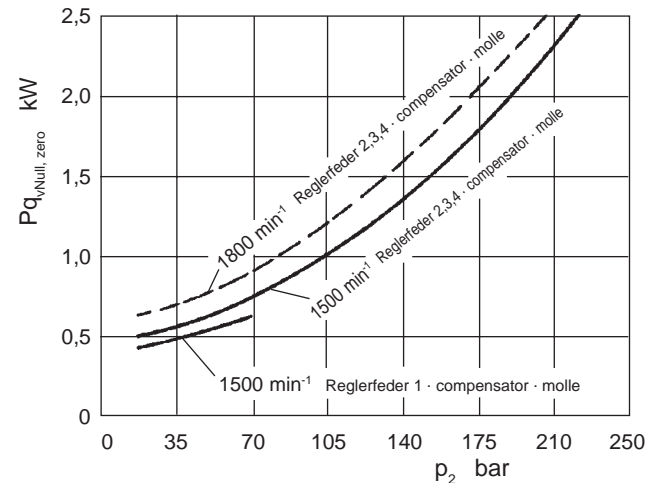

Bild / Fig. 34: Baugröße · Model · Grandezza J-V70

Axialkolben-Verstellpumpen

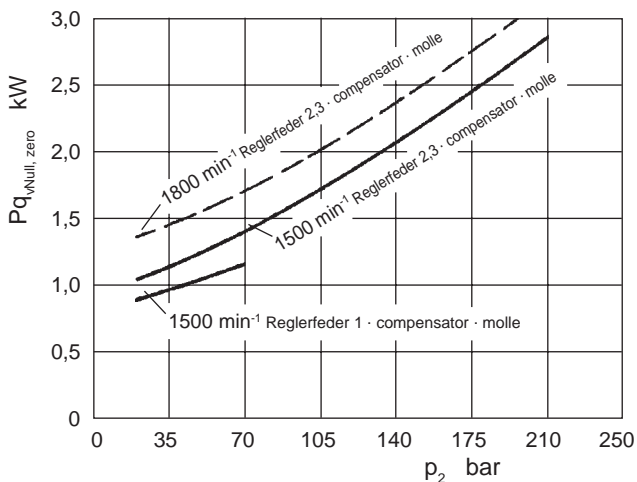
Variable displacement axial piston pumps

Pompe variabili a pistonni assiali

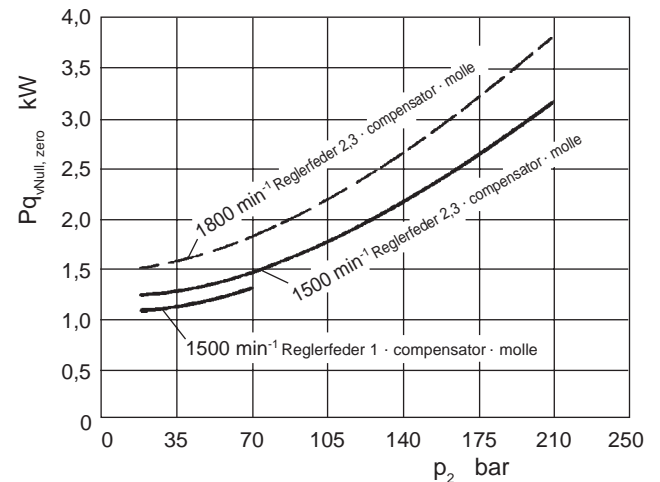
Baureihe J-V

Series J-V

Serie J-V

Geräteabmessungen · Installation dimensions · Dimensioni

Dargestellt sind alle Varianten in Drehrichtung rechts. Bei Einheiten in linksdrehender Ausführung (s. Tabelle 3) wird das Regelgerät auf der gegenüberliegenden Seite montiert; weiterhin wechselt die Durchflußrichtung und damit Druck- und Sauganschluß. Gegebenenfalls separates Maßblatt anfordern.

Only the right hand rotation models are shown. If the unit is required with lefthand-rotation (see table 3) then the control is mounted on the opposite side to that shown in the illustrations, the direction of flow and consequently the connection of the pressure and suction lines will also be opposite to those shown. If required, ask for a separate data sheet.

Sono illustrate tutte le versioni a rotazione destra. L'unità a rotazione sinistra (vedi tabella 3) presenta il regolatore installato sul lato opposto; inoltre cambiano, al variare della direzione della portata, le posizioni delle bocche di mandata e aspirazione. Eventualmente richiedere disegni a parte.

Förderstrom- und Druckeinstellbereiche s. Tabellen 2 und 4.

For outlet flow and pressure setting range see tables 2 and 4.

Per i campi di regolazione portata e pressione vedi tabelle 2 e 4.

Baugröße J-V8 · Model J-V8 · Grandezza J-V8



Bild / Fig. 35: Baugröße · Model · Grandezza J-V8A*RX

Baugröße J-V15 · Model J-V15 · Grandezza J-V15

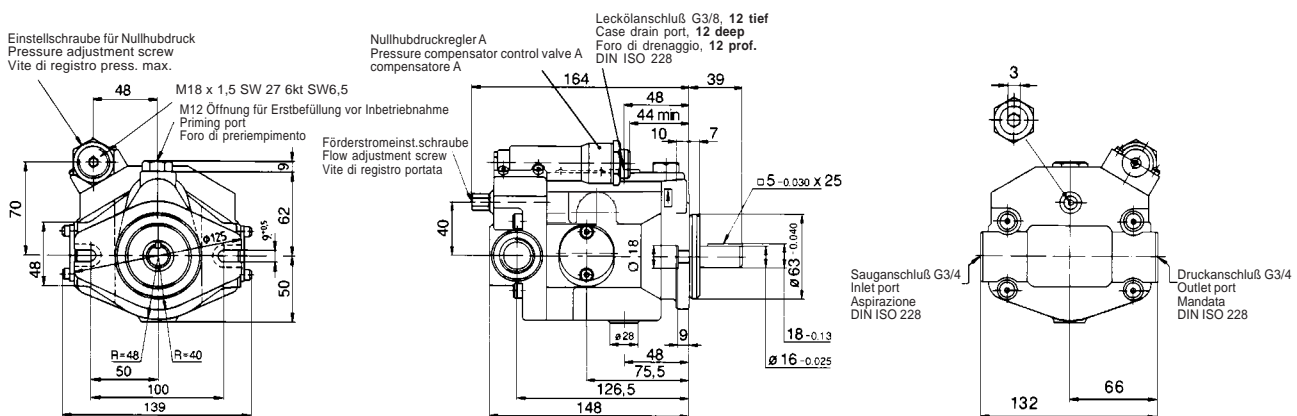

Bild / Fig. 36: Baugröße · Model · Grandezza J-V15 A*RX

A*RX*RC
SA**RX

Axialkolben-Verstellpumpen
Variable displacement axial piston pumps
Pompe variabili a pistonni assiali

Baureihe J-V
Series J-V
Serie J-V

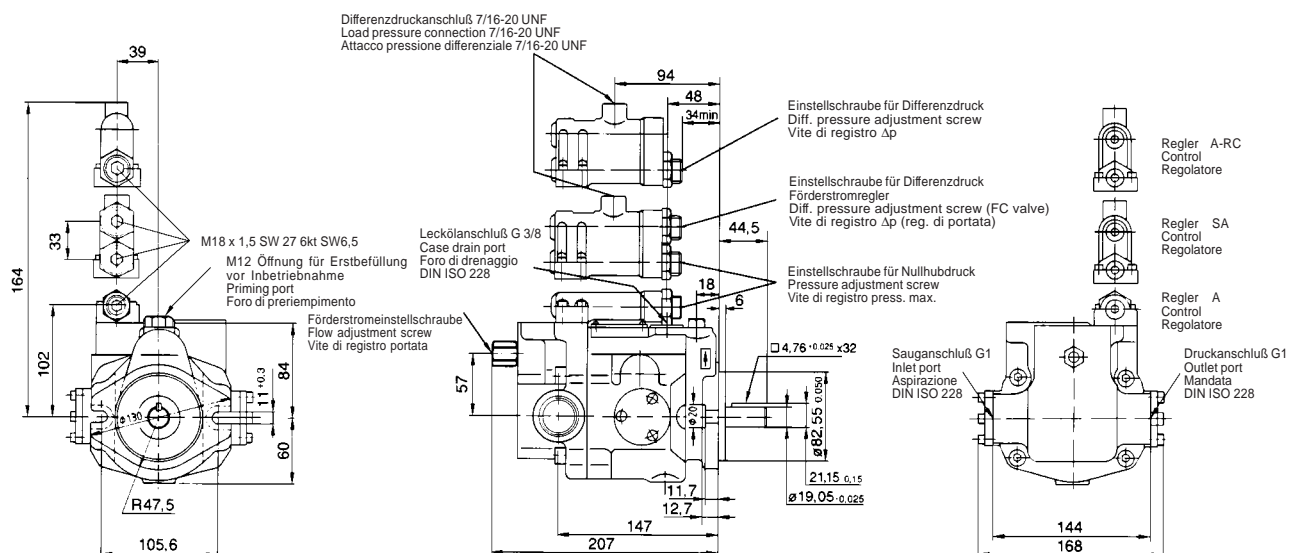
Baugröße J-V15 (Fortsetzung) · Model J-V15 (contd.) · Grandezza J-V15 (seguito)



Bild / Fig. 37: Baugröße · Model · Grandezza J-V15A*R

A*R*RC
SA**R



Bild / Fig. 38: Baugröße · Model · Grandezza J-V15C**RHx
C**RJ*X

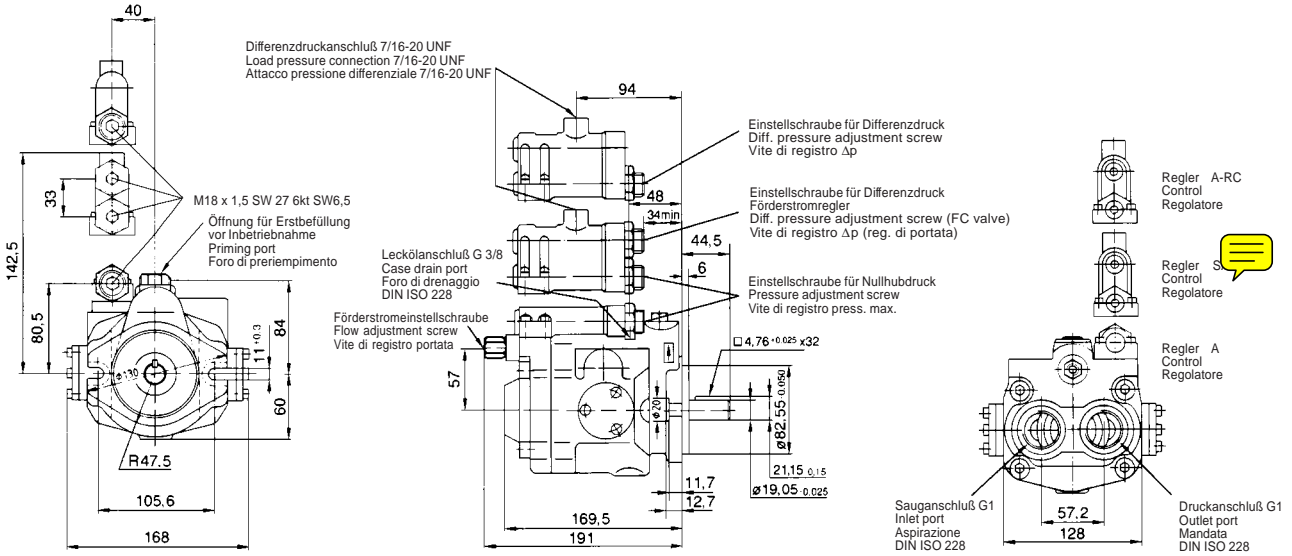

Bild / Fig. 39: Baugröße · Model · Grandezza J-V15 D**R*X

Axialkolben-Verstellpumpen
Variable displacement axial piston pumps
Pompe variabili a pistoni assiali

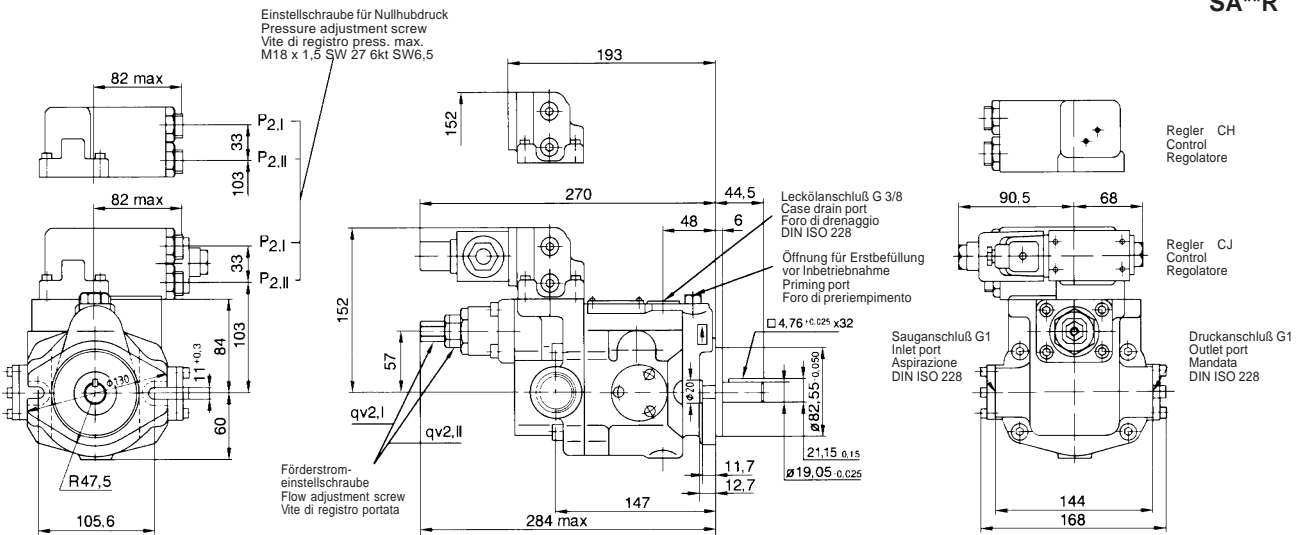
Baureihe J-V
Series J-V
Serie J-V

Baugröße J-V23 · Model J-V23 · Grandezza J-V23

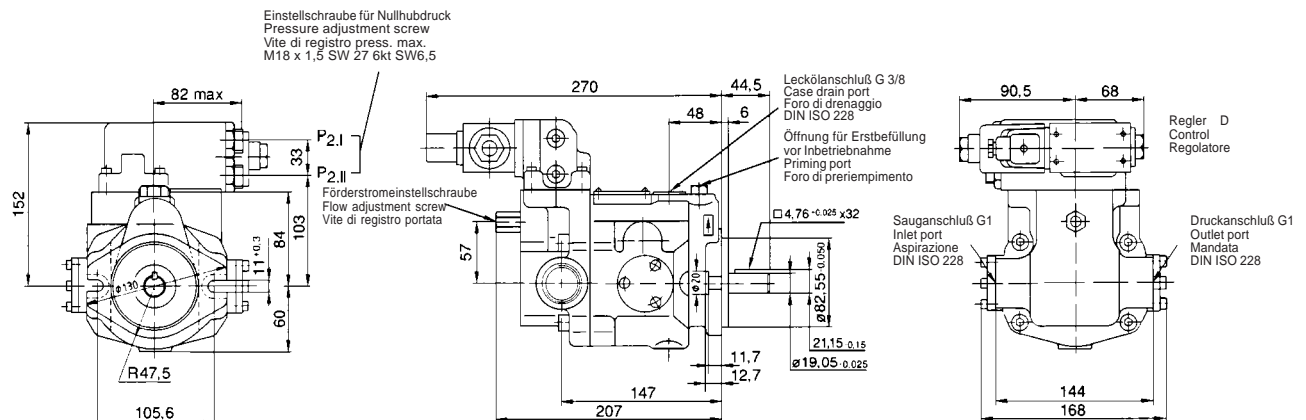

Bild / Fig. 40: Baugröße · Model · Grandezza J-V23A*RX

A*RX*RC
SARX**

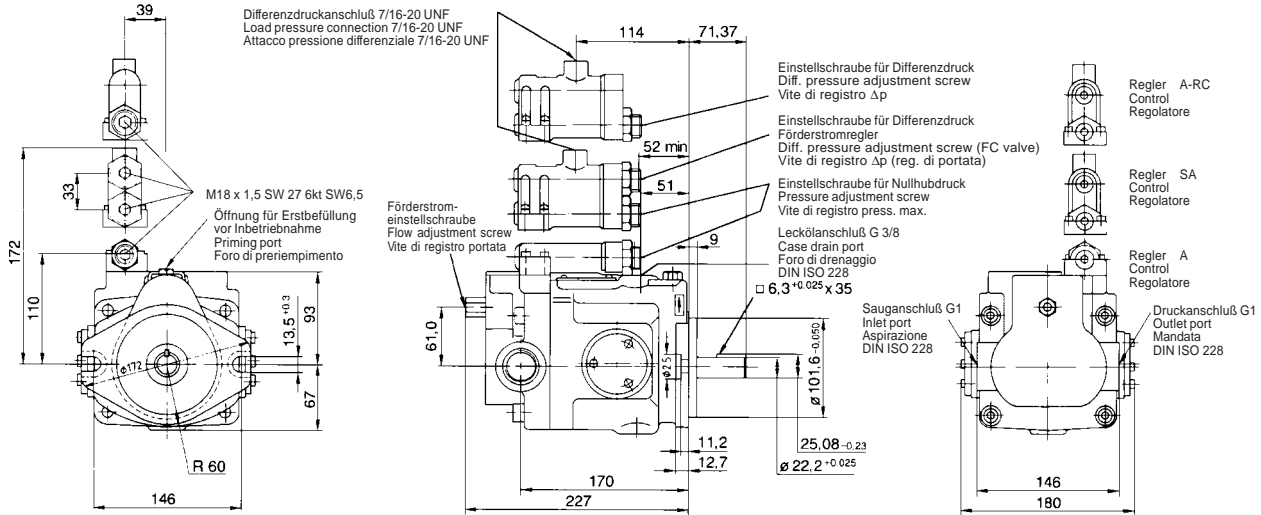

Bild / Fig. 41: Baugröße · Model · Grandezza J-V23A*R

A*R*RC
SAR**

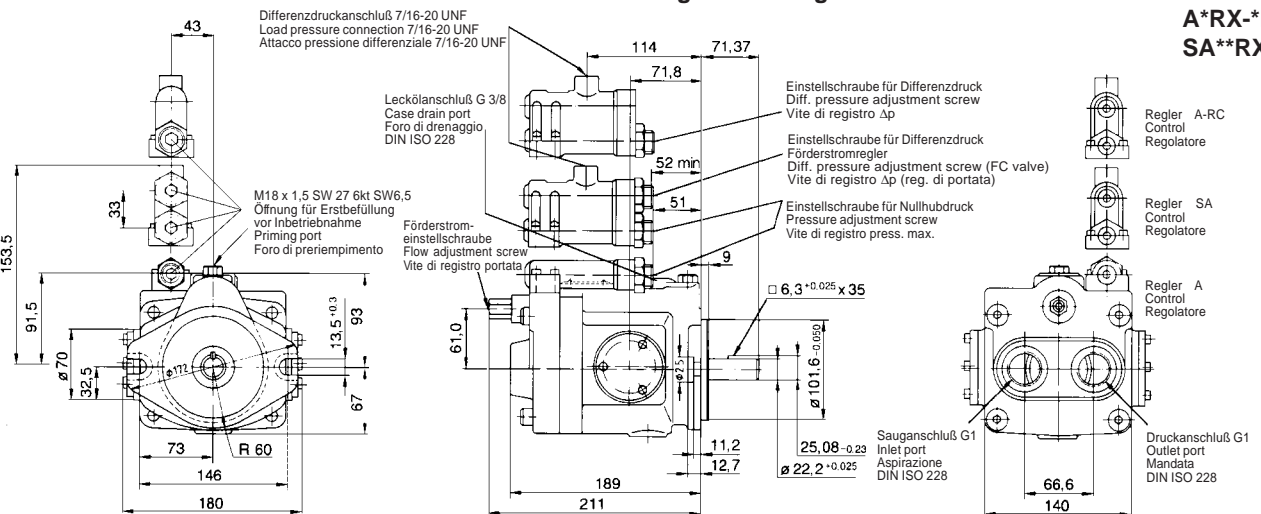

Bild / Fig. 42: Baugröße · Model · Grandezza J-V23CRHX**

CRJ*X**

Axialkolben-Verstellpumpen
Variable displacement axial piston pumps
Pompe variabili a pistoni assiali

Baureihe J-V
Series J-V
Serie J-V

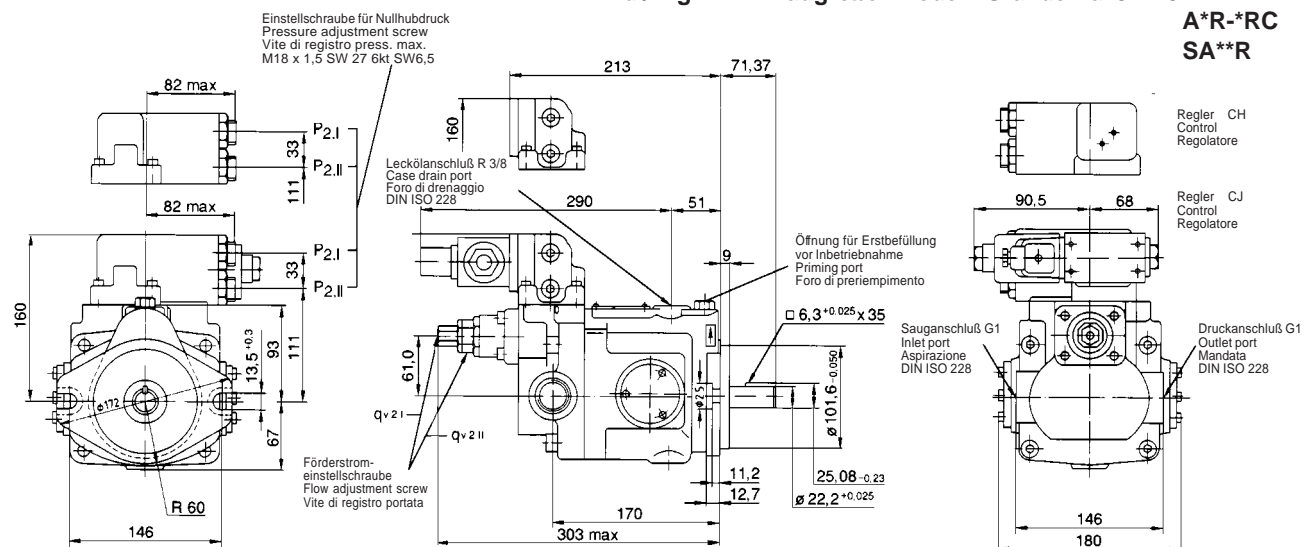
Baugröße J-V23 (Fortsetzung) · Model J-V23 (contd.) · Grandezza J-V23 (seguito)



Bild / Fig. 43: Baugröße · Model · Grandezza J-V23DR*X**



Bild / Fig. 44 Baugröße · Model · Grandezza J-V23 ACP**
ARC**CP**
SACP********

Axialkolben-Verstellpumpen
Variable displacement axial piston pumps
Pompe variabili a pistonni assiali

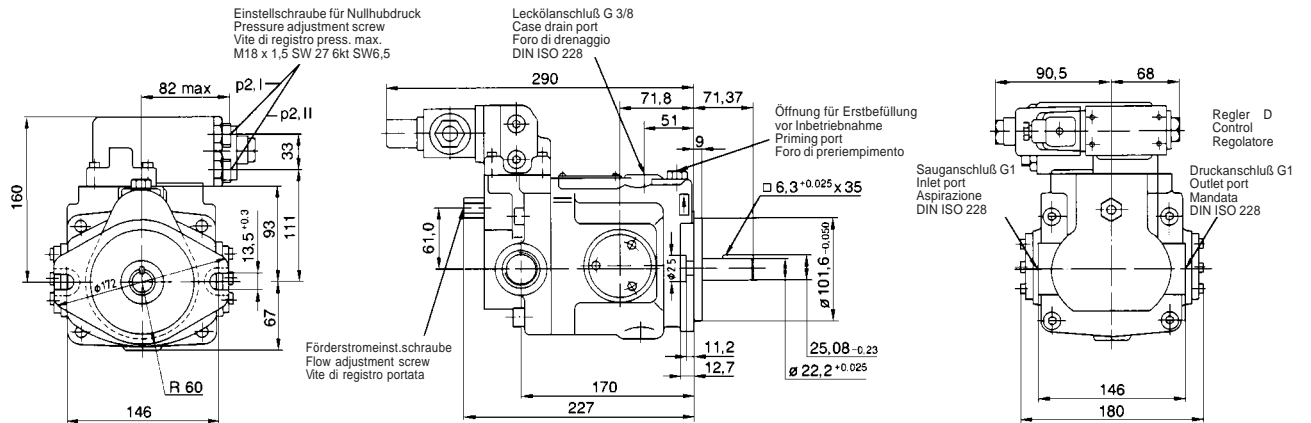
Baureihe J-V
Series J-V
Serie J-V

Baugröße J-V38 · Model J-V38 · Grandezza J-V38

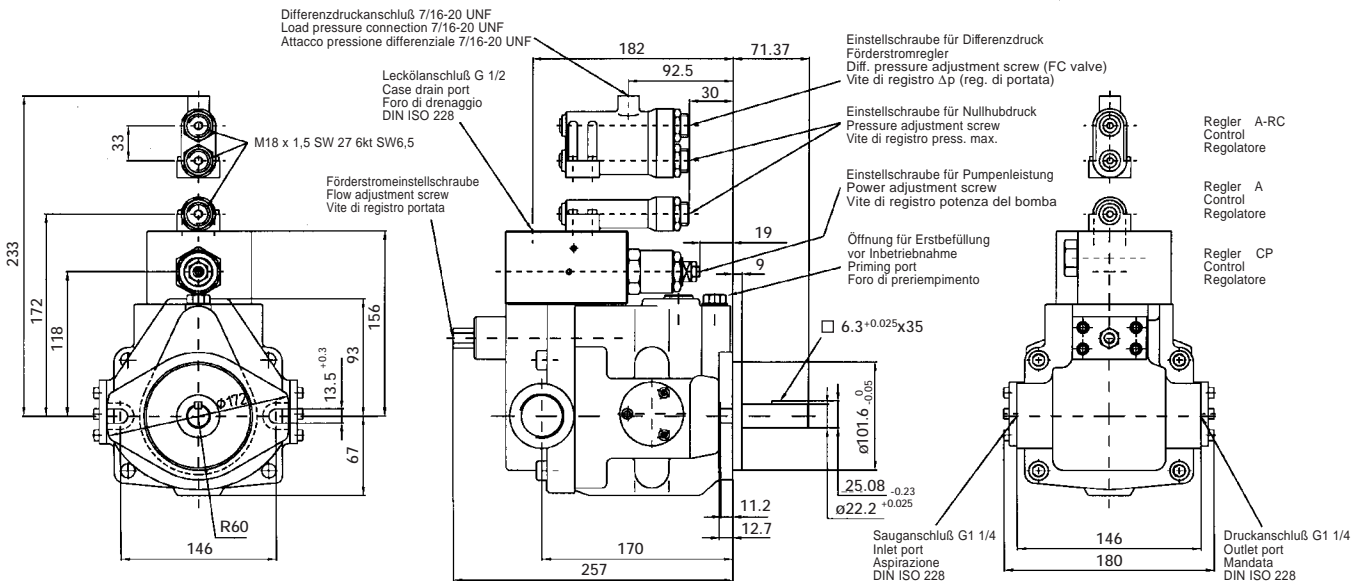
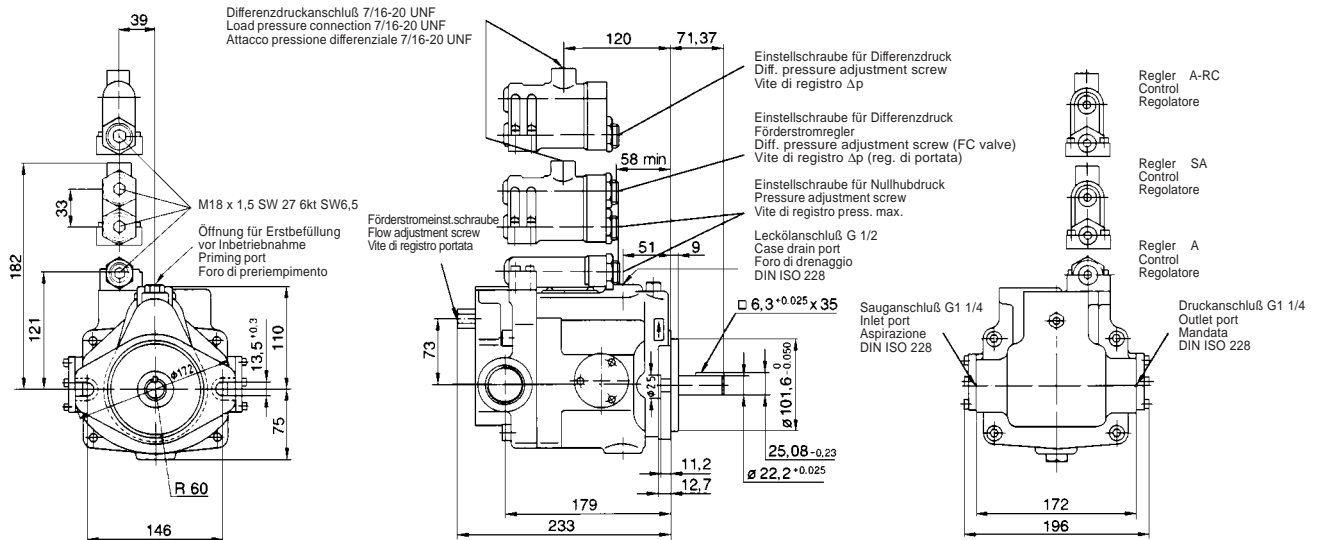

**Bild / Fig. 45: Baugröße · Model · Grandezza J-V38 A*RX
A*RX-RC
SA**RX**

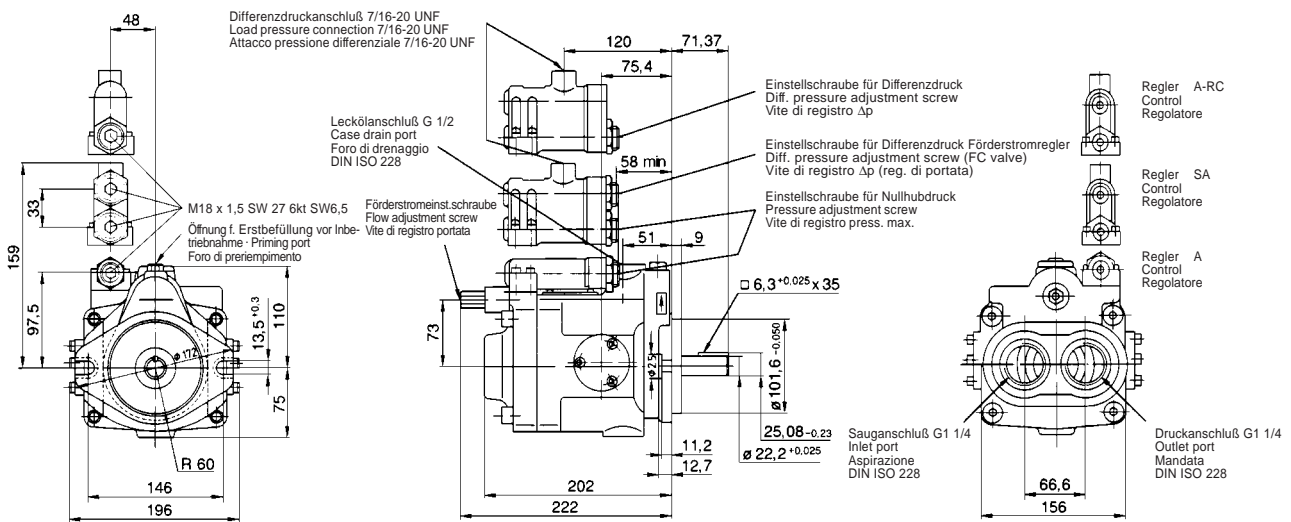

**Bild / Fig. 46: Baugröße · Model · Grandezza J-V38A*R
A*R-RC
SA**R**

Axialkolben-Verstellpumpen
Variable displacement axial piston pumps
Pompe variabili a pistoni assiali

Baureihe J-V
Series J-V
Serie J-V

Baugröße J-V38 (Fortsetzung) · Model J-V38 (contd.) · Grandezza J-V38 (seguito)



Bild / Fig. 47: Baugröße · Model · Grandezza J-V38 ACP****
ARC**CP****
SACP****



Bild / Fig. 48: Baugröße · Model · Grandezza J-V38 CRHXC**RJ*X**

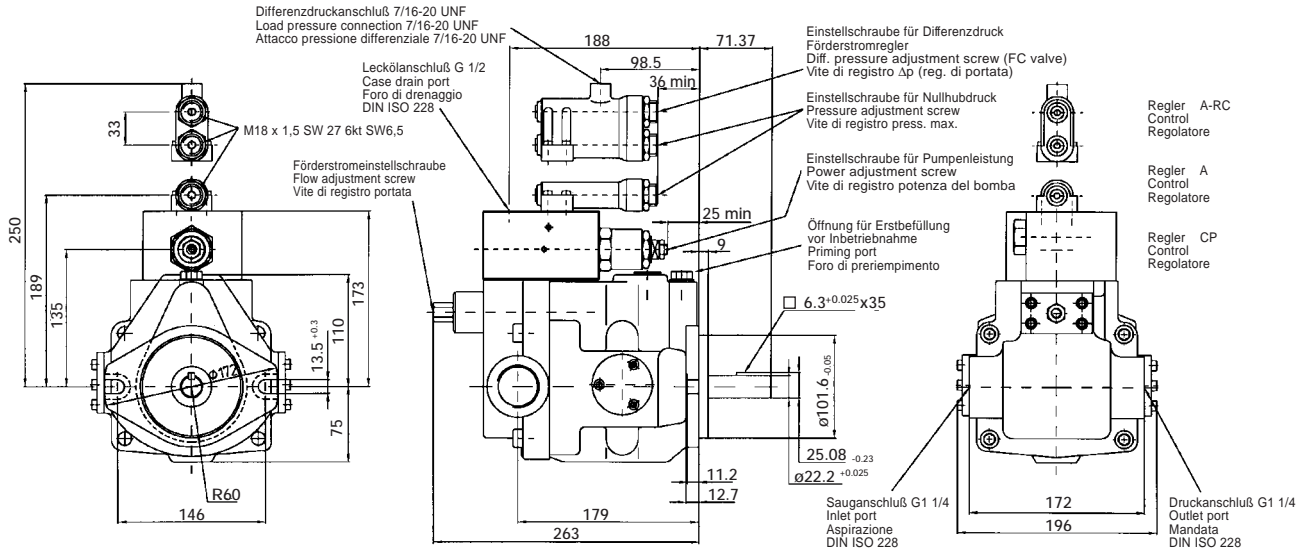

Bild / Fig. 49: Baugröße · Model · Grandezza J-V38DR*X**

Axialkolben-Verstellpumpen
Variable displacement axial piston pumps
Pompe variabili a pistonni assiali

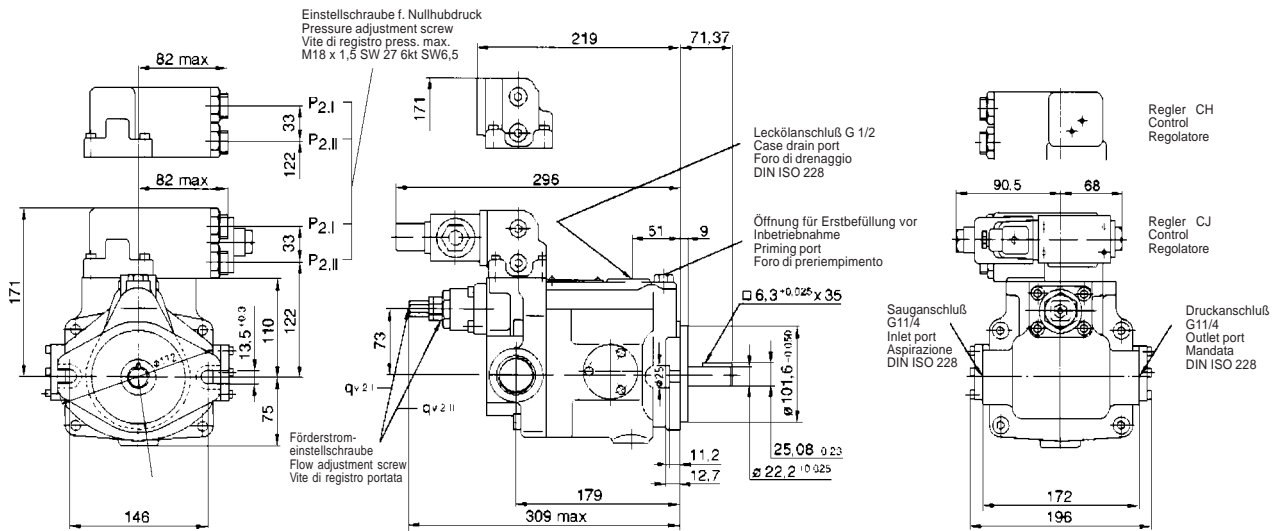
Baureihe J-V
Series J-V
Serie J-V

Baugröße J-V50 · Model J-V50 · Grandezza J-V50

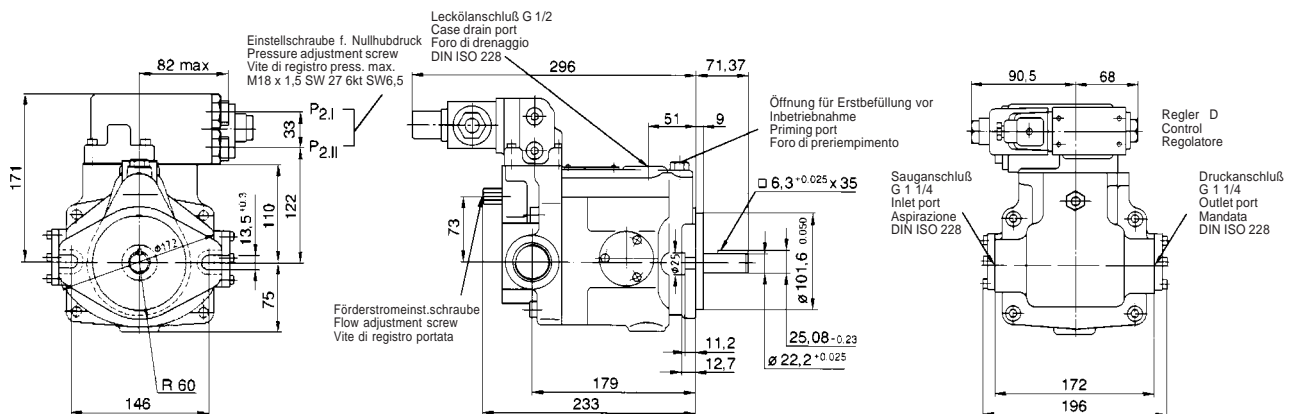
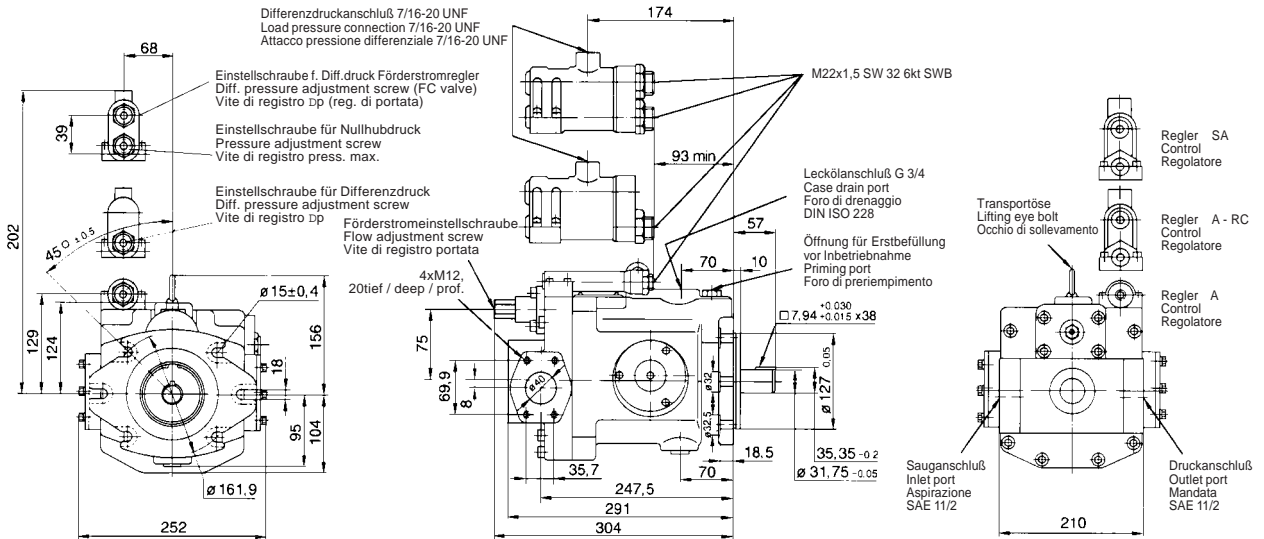

**Bild / Fig. 50: Baugröße · Model · Grandezza J-V50A*RX
 A*RX*RC
 SA*RX**



Bild / Fig. 51: Baugröße · Model · Grandezza J-V50 ACP**
 A**RC**CP**
 SA**CP****

Axialkolben-Verstellpumpen
Variable displacement axial piston pumps
Pompe variabili a pistoni assiali

Baureihe J-V
Series J-V
Serie J-V

Baugröße J-V70 · Model J-V70 · Grandezza J-V70

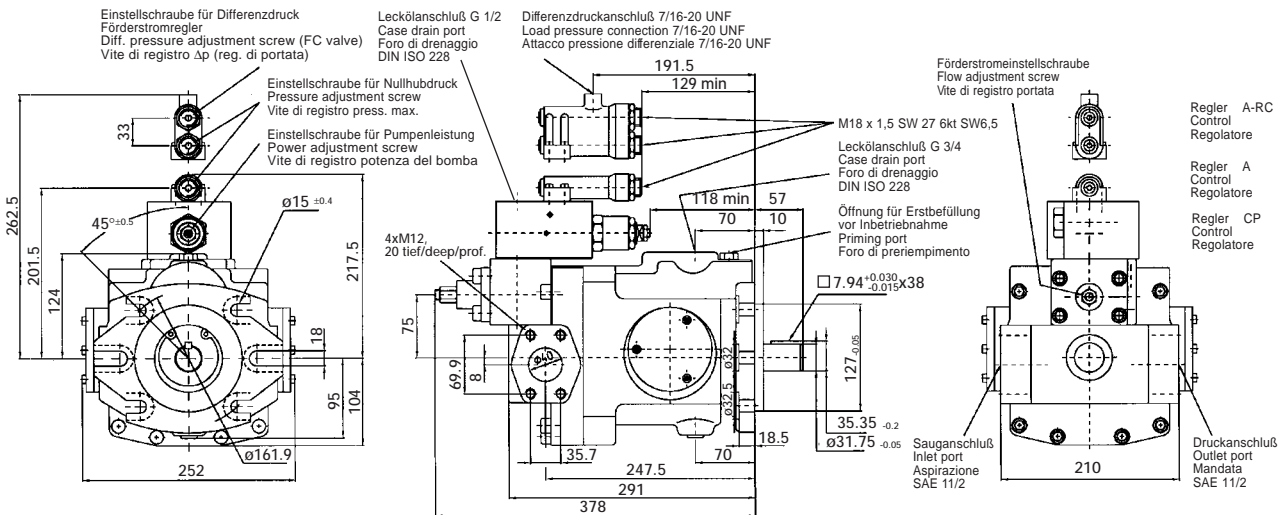
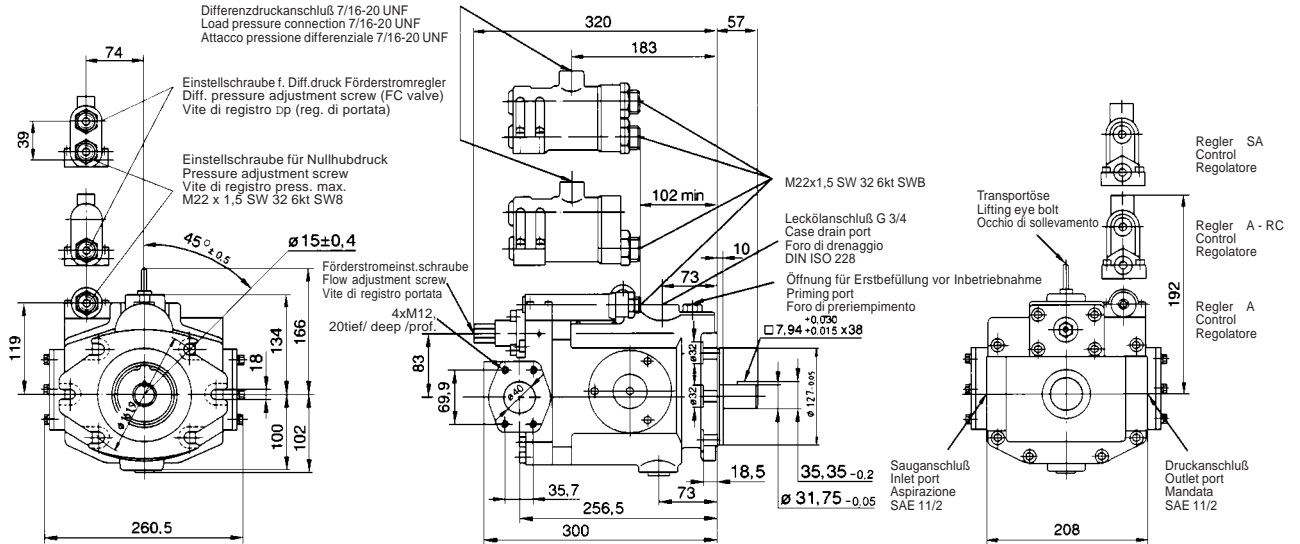

**Bild / Fig. 52: Baugröße · Model · Grandezza J-V70 A*RX
 A*RX*RC
 SA**RX**



Bild / Fig. 53: Baugröße · Model · Grandezza J-V70CRHX**



Bild / Fig. 54: Baugröße · Model · Grandezza J-V70 ACP**
 A**RC**CP**
 SA**CP****

Axialkolben-Verstellpumpen
Variable displacement axial piston pumps
Pompe variabili a pistoni assiali

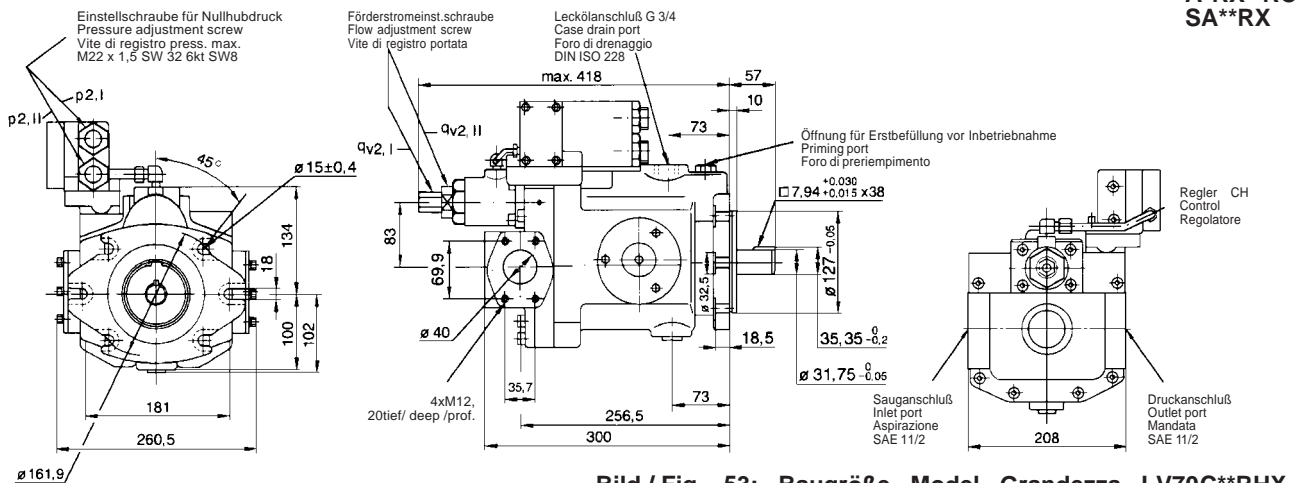
Baureihe J-V
Series J-V
Serie J-V

Durchtriebspumpen mit SAE-Anschluß, Geräteabmessungen · Through drive pumps with SAE connection size, Installation dimensions · Pompe ad albero passante con attacco SAE, dimensioni

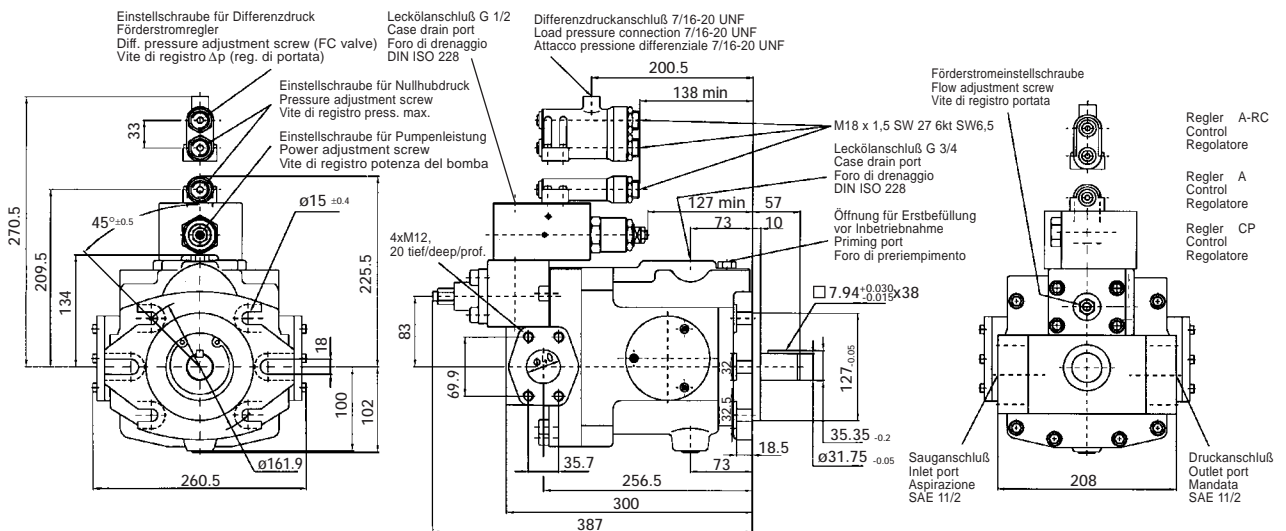

Bild / Fig. 51:

Baugröße Size Grandezza	J-V 23	J-V 38	J-V 70
A mm	232	238	335
B mm	106,4		146
C mm	10		
D mm	85,83 + ₀ ^{0,15}		107,77 + ₀ ^{0,15}
E mm	82,60 + ₀ ^{0,026}		101,60 + _{0,036} ^{0,071}
F mm	2 x 3/8-16 UNC-2B		2 x 1/2-13 UNC-2B
Verzahnung Shaft spline data Dati della dentatura	gemäß · according · conforme a SAE A Teilkreis ø · pitch dia. · diamet. primitivo = 14,2875mm Eingriffswinkel · press. angle · angolo di press. = 30° Zähnezahl · no. of teeth · numero denti = 9 Teilung · pitch · modulo = 16/32		gemäß · according · conforme a SAE B Teilkreis ø · pitch dia. · diamet. primitivo = 20,638mm Eingriffswinkel · press. angle · angolo di press. = 30° Zähnezahl · no. of teeth · numero denti = 13 Teilung · pitch · modulo = 16/32
Zul. Durchtriebsmoment bei α max. und 210 bar · Allowable output torque at α max. and 210 bar · Momento torcente amm. con α max. e 210 bar	46 Nm	55 Nm	200 Nm
Drehrichtung · Sense of rotation · Senso di rotazione	nur rechtsdrehend · only clockwise · solo destro		
Lage der Arbeitsanschlüsse · Port position · Posizione delle bocche	nur radial · only radial · solo radiali		
Lieferbare Regelorgane · Available control devices · Regolatori disponibili	Regler · control · regolatore A* A*-RC SA**		
Kombinationsmöglichkeiten · Possible combinations · Possibilità di abbinamento	J-V 15 ¹⁾ Zahnradpumpen · gear pumps · pompe ad ingranaggi		J-V 23, J-V 38 ¹⁾

Tabelle / Table / Tabella 6:

¹⁾ weitere Varianten auf Anfrage · other variants on demand · altre varianti a richiesta

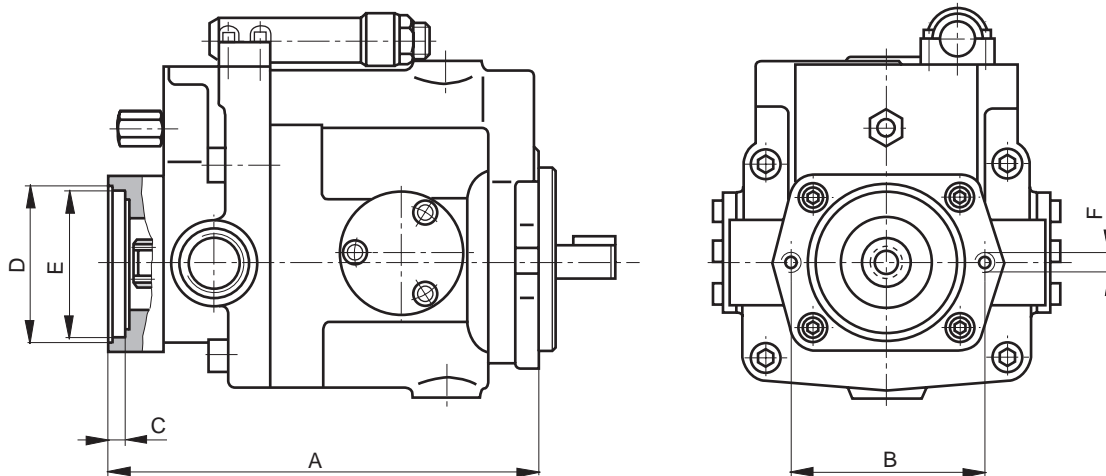
Axialkolben-Verstellpumpen
Variable displacement axial piston pumps
Pompe variabili a pistonni assiali

Baureihe J-V
Series J-V
Serie J-V

Notizen · Notes · Appunti

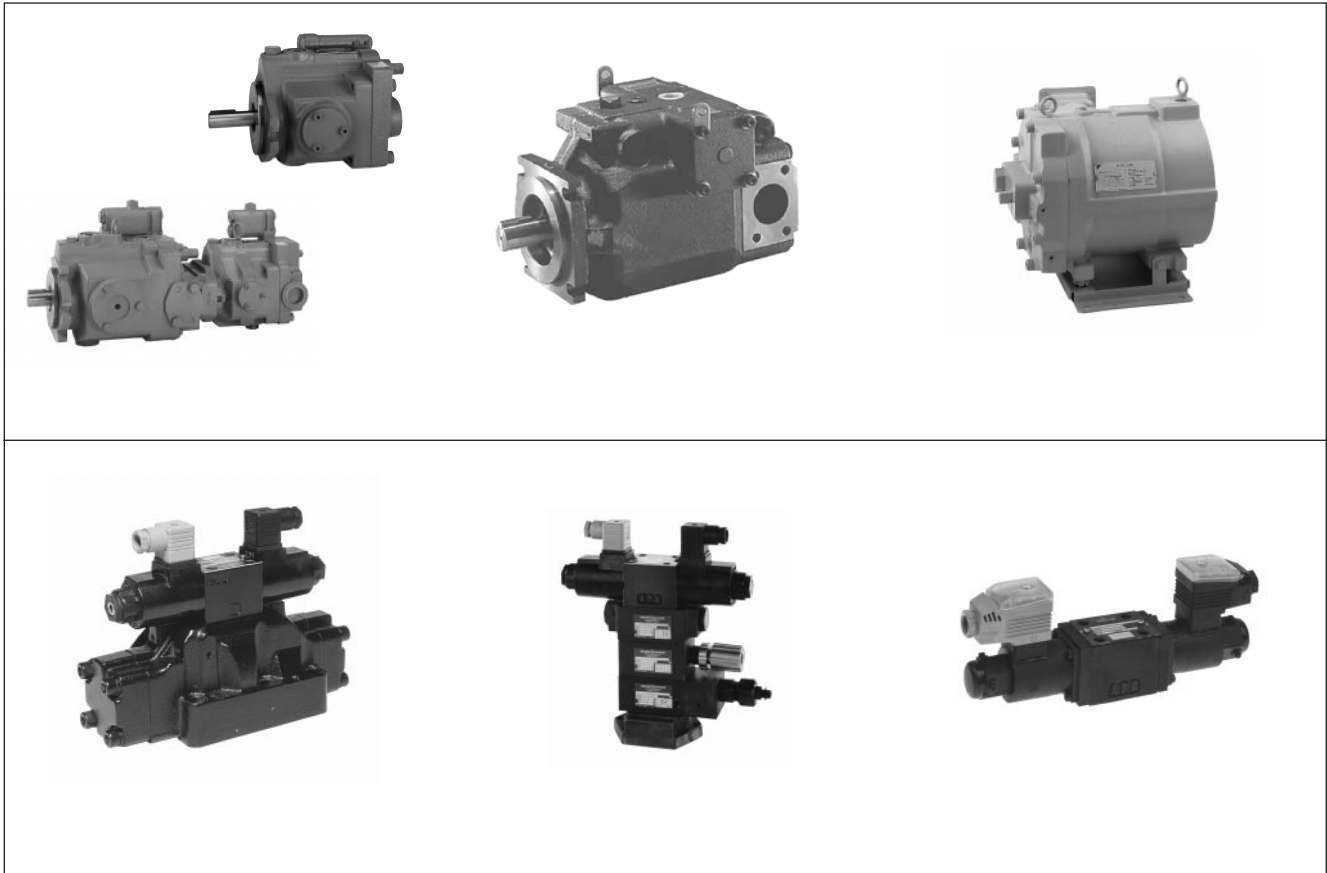

Zeus Hydratech Ltd
2 Swallow Drive
Alsager
Stoke-On-Trent
Staffordshire
ST7 2GJ
United Kingdom

Tel:-44 (0)1270 898594
www. zeushydratech.com