

ZEUS HYDRATECH LTD

Global Suppliers of Premium Hydraulic Components

Email: sales@zeushydratech.com
Tel: +44(0)1172 130042

HPVR Series

HPVR Series

Axial Piston Pumps

**Sizes: HPVR-6,
HPVR-10,
HPVR-15,
HPVR-20,
HPVR-29**

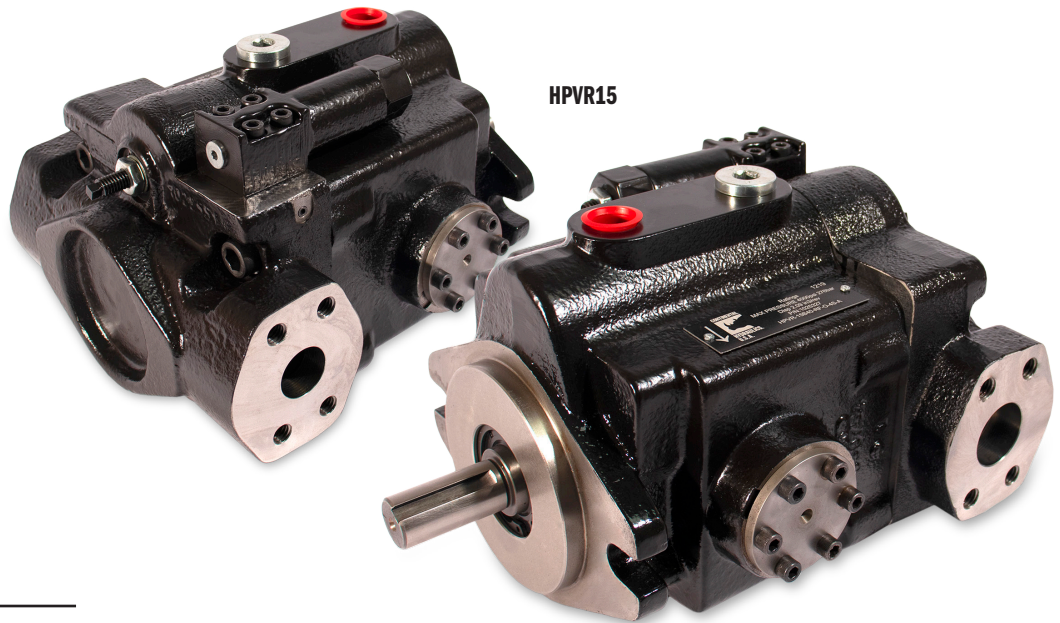

► DESCRIPTION:

The HPVR series of in-line axial piston variable displacement pumps, are available in five displacements and three compact frame sizes.

These pumps feature medium-high working pressure capabilities that will meet most applications.

The output flow and pressure is controlled by a variety of control options, and can easily work in conjunction with external control components making them the perfect choice for almost any application.

The HPVR series pumps are available in both SAE and ISO mounting 2 bolt patterns. Porting is available in rear and side locations as well as thru-drive configurations.

► PERFORMANCE:

		HPVR-6	HPVR-10	HPVR-15	HPVR-20	HPVR-29	
Volumetric Displacement	cu. in./rev.	0.88	1.26	2.09	2.62	3.97	
	ml/rev.	14.4	21.1	34.2	42.9	65	
Pump Delivery @ 1750 RPM	GPM	6.67	9.9	16.6	19.85	29	
	LPM	25.2	37.5	62.8	75.03	109.8	
Operating Pressures	Intermittent*	PSI	4500	4500	4500	4500	
		BAR	310	310	310	310	310
	Continuous	PSI	4000	4000	4000	4000	4000
		BAR	275	275	275	275	275
	Minimum**	PSI	200	200	200	200	200
		BAR	14	14	14	14	14
Shipping Weights	Rear Ports	lbs.	27	39	51	75	75
		kg	12.4	17.7	23.2	34	34
	Side Ports	lbs.	35	50	63	90	90
		kg	15.9	22.7	28.6	41	41
	Side Ports Tandem	lbs.	-	52	69	100	100
		kg	-	23.6	31.3	45.5	45.5

* This pressure should not exceed 10% of the duty cycle and not exceed 6 consecutive seconds.

** Pumps operating at less than 150 PSI (10 bar) may overheat and shorten pump life.

► TABLE OF CONTENTS:

Description and Benefits 1-2
 Compensator Description of Operation 3-5
 HPVR-6 6-10
 HPVR-10 11-16
 HPVR-15 17-22
 HPVR-20 23-28
 HPVR-29 29-34
 Seal and Compensator Kits 35

HPVR Series

Axial Piston Pumps

What Makes HPVR Series Axial Piston Pumps Your Best Buy?

Variable volume pressure compensated piston pumps match flow to system demand. Your system will generate less heat, and may not need a heat exchanger. Your system can be kept simpler too, with fewer valves and regulators, while still maintaining constant pressure. For long term reliability, and optimum performance, PowrFlow™ HPV Axial Piston Pumps are your best value.

Features and Benefits

- Simple Construction for long, dependable service.
- More contamination-tolerant than competitive pumps to improve dependability and reduce maintenance costs.
- Quiet operation simplifies meeting system sound level standards.
- Economical - low overall cost for a high performance variable volume pump.
- Efficient, energy-saving design.

Three Compensator Options for All Kinds of Applications

- Standard Compensator - designed for quick response. On stroke response less than 120 ms., Off stroke response 50 ms.
- Remote Compensator - provides the same pressure compensated performance with the added flexibility and convenience of remote pressure adjustment or multiple pressure levels.
- Load Sensing Compensator - allows the pump to maintain constant flow to the system regardless of fluctuating loads to maintain maximum system efficiency and minimum heat loss.

Power Flow Piston Pumps

Standard SAE 2-Bolt Flange Mount. Available in right or left-hand rotation. Readily interchangeable with other piston pumps.

Drive Shaft Choices

- SAE Straight Key
- Splined Through Drive Option.

Replaceable Thrust Plate
Simplifies servicing.

Nine Piston Rotating Group
Provides smooth power and quiet operation. Individually replaceable pistons.

Heavy Duty Construction
Designed for rugged use in industrial and mobile applications. Beefed up case also contributes to reduced sound levels for quiet operation.

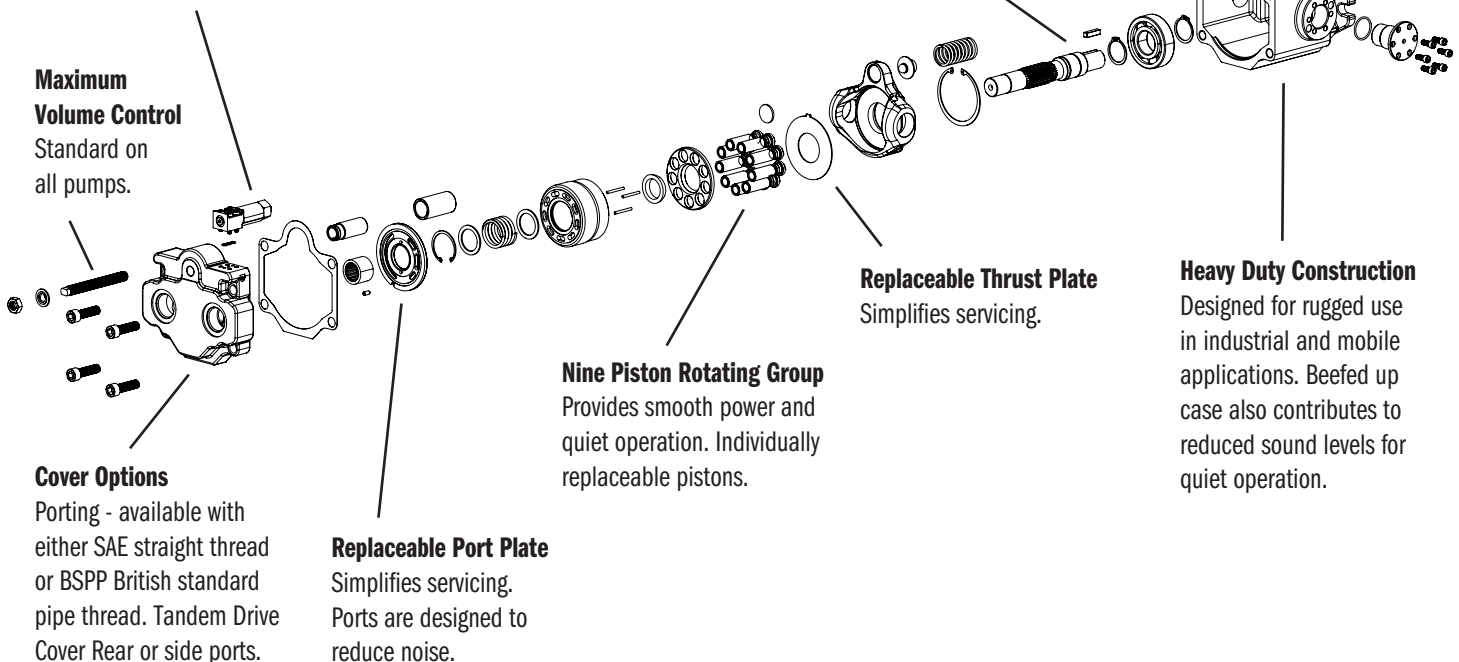

► **CONTROLS:**

PRESSURE COMPENSATED CONTROL (Standard)

By controlling the system pressure, the standard pressure compensated control changes pump displacement to match the system's flow requirement. Simply stated: a pressure compensated pump will provide variable flow at a constant pressure setting.

Pump displacement is mechanically controlled by the angle of the swash plate. The swash plate angle is controlled by the extension of the compensator plunger working against the swash plate bias spring. The compensator senses downstream pressure and adjusts displacement to maintain the set pressure.

The control would be used on systems requiring variable flow but unchanging pressure.

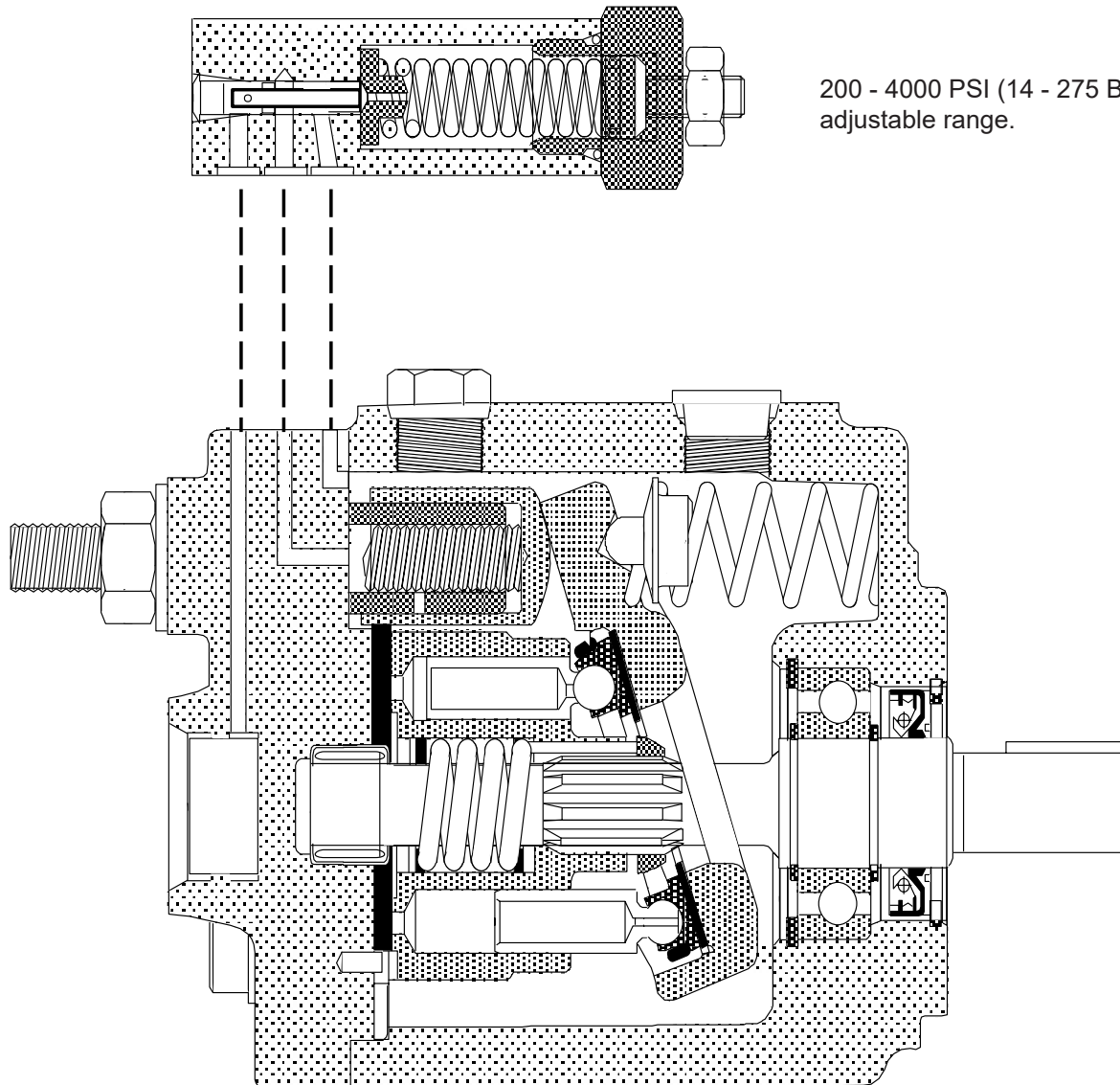

200 - 4000 PSI (14 - 275 Bar)
adjustable range.

► **CONTROLS:**

REMOTE PRESSURE CONTROL (Code 7)

By controlling the system pressure, the standard The remote pressure control works similar to the standard pressure compensated control, but with some added features. This is a two stage compensator with two pressure adjustments: one for the lower pressure limit and one for the upper pressure limit.

A vent line* is required to run back to the reservoir. When this line is vented, the pump will go to the lower pressure setting. When this line is blocked, the pump will

go to the upper pressure limit. Pressure in this line may be controlled by one or more relief valves. These valves should be direct acting and capable of pressures up to 3750 PSI (259 bar). The setting of these relief valves will control the pump's pressure setting.

The control would be used on systems where flow requirements are variable and multiple pressures are desirable.

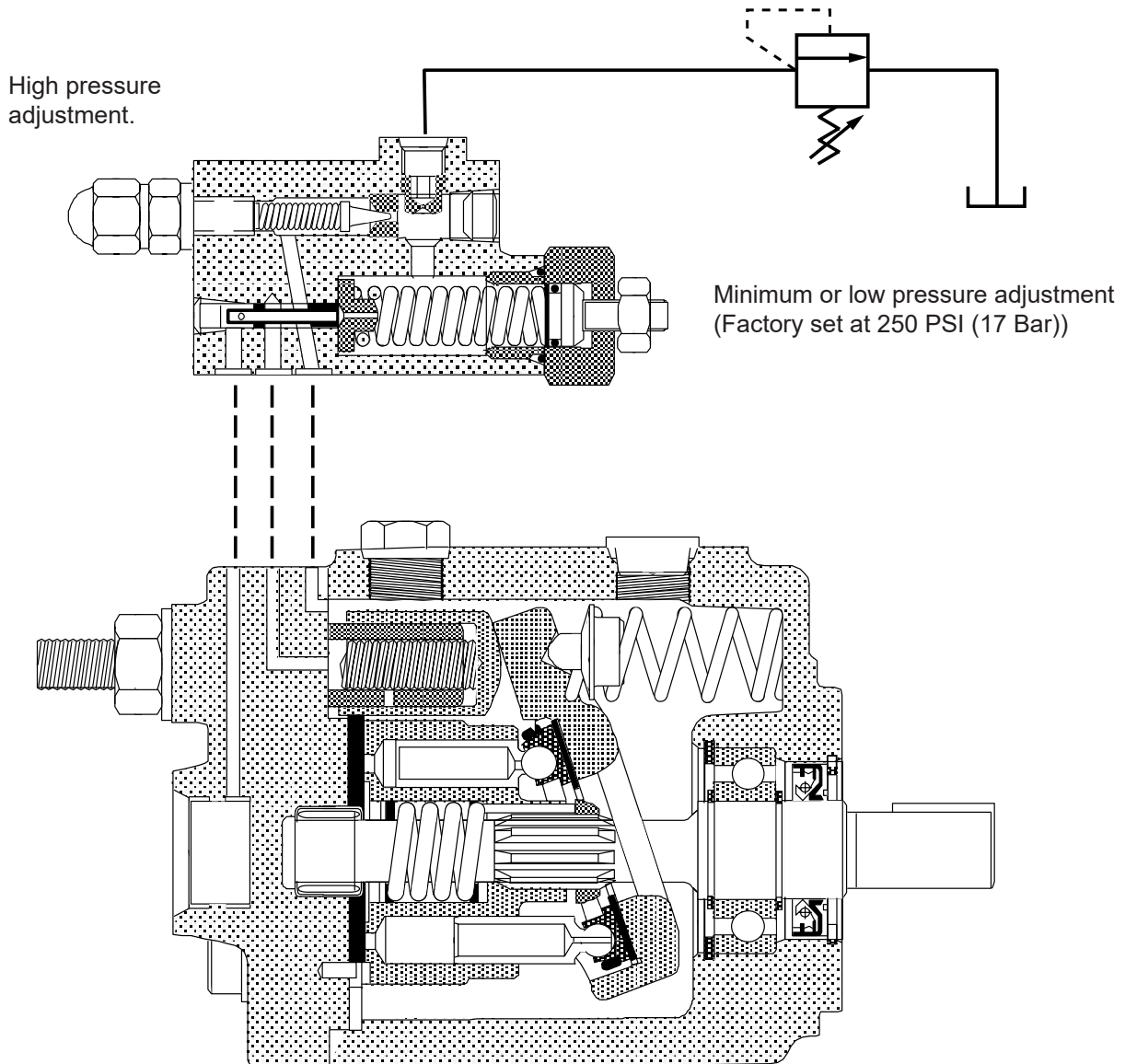

► **CONTROLS:**

LOAD SENSING CONTROL (Code 19)

The load sensing control is designed to deliver constant flow across an orifice, and to adjust pressure to meet the system's demands. This is accomplished by using a flow control valve between the pump outlet and actuator. This type of control is often called "flow compensating".

A sense line* must be connected between the downstream side of the flow control valve and the pump compensator. Through this line, the compensator senses fluctuations in system pressure requirements.

There are two adjustments on this compensator:
(A) Upper adjustment sets the upper pressure limit;
(B) Lower adjustment sets the pressure differential of the flow control valve. This setting comes preset to 250 PSI (17.2 Bar).

When this control is combined with a variable flow control (like a proportional valve), it will deliver both variable flow and variable pressure.

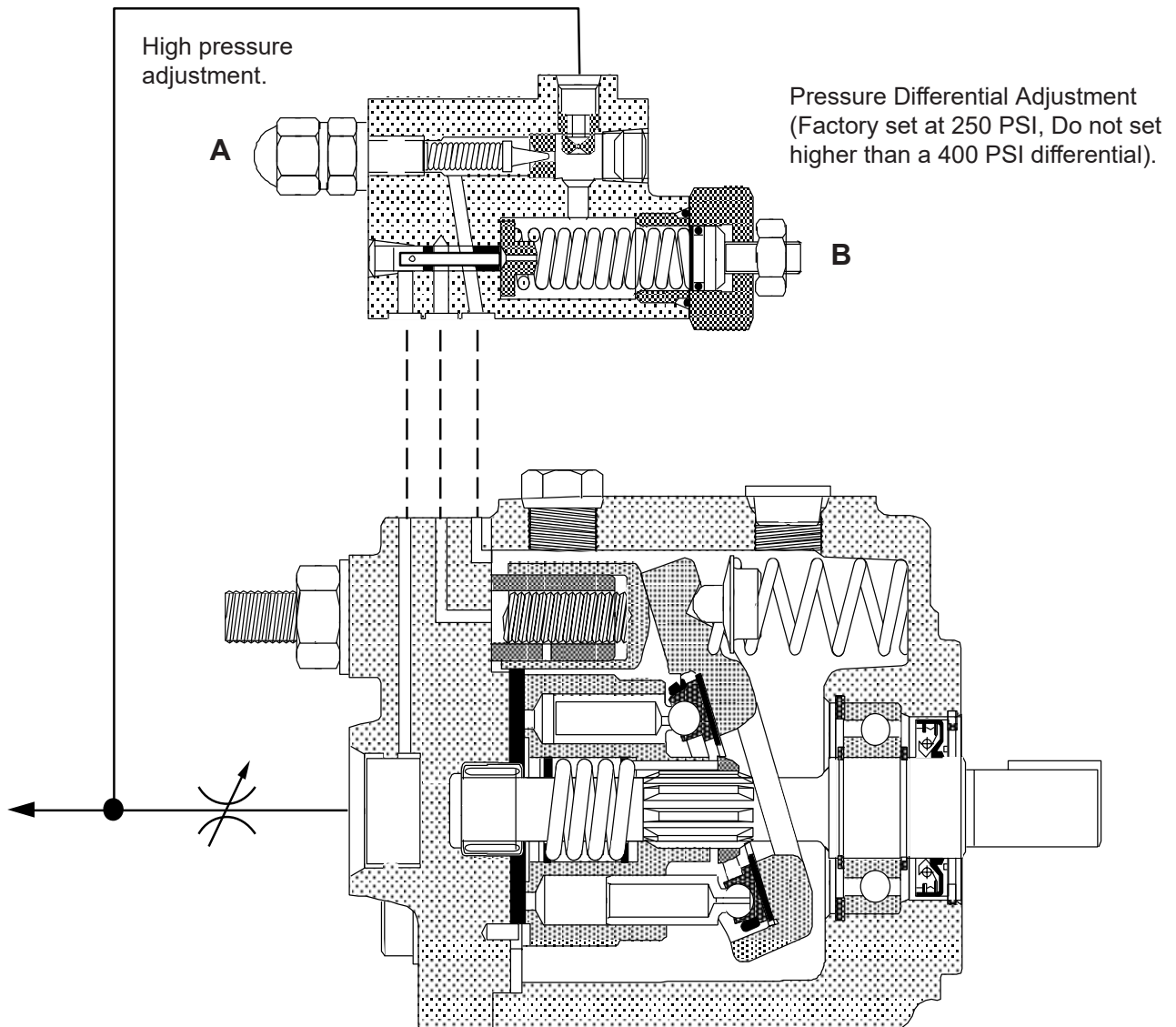

HPVR-6

Axial Piston Pumps

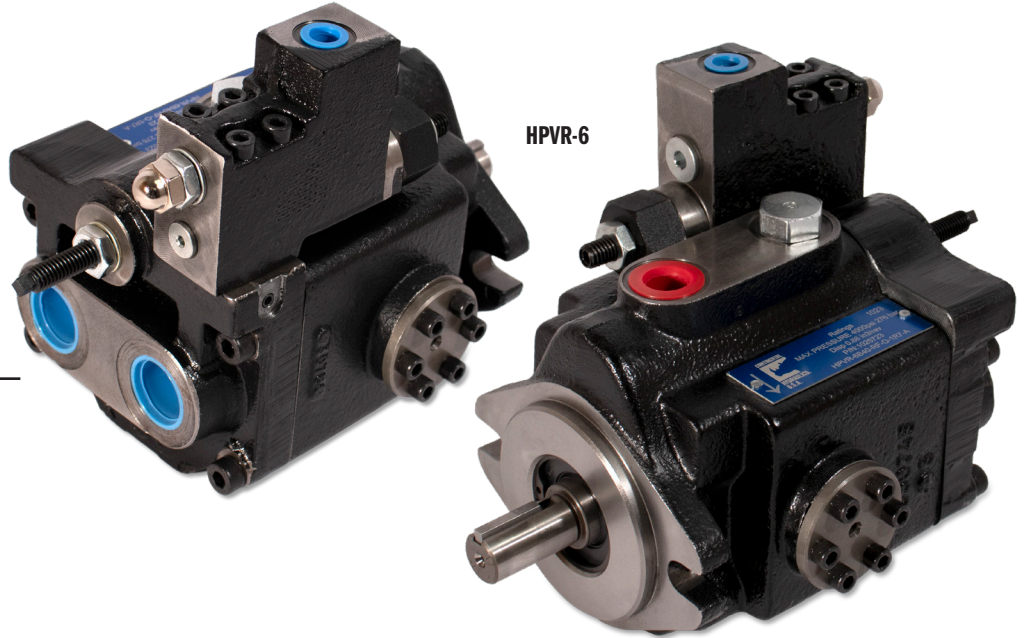

► SPECIFICATIONS:

CASE AND INLET PORT

Speed	Minimum Inlet Pressure						Maximum Case Pressure	
	Pressure Gauge				Absolute Pressure			
rpm	psi	bar	in.-Hg	mm-Hg	psi	bar	psi	bar
1800	-3	-0.21	-6.12	-155.46	11.7	0.81	10	0.69
2050	-3	-0.21	-6.12	-155.46	11.7	0.81	7	0.48
2100	-3	-0.21	-6.12	-155.46	11.7	0.81	5	0.34
2750	-2.53	-0.17	-4.79	-121.67	12.35	0.8	5	0.34
2900	-0.96	-0.17	-1.97	-49.94	13.74	0.9	5	0.34
3000	0.00	0.00	0.00	0.00	14.7	1.01	5	0.34

PRESSURE AND VOLUME ADJUSTMENT SENSITIVITY

Pressure Adjustment	Pressure Change / Turn	650 PSI	44.8 Bar
Volume Adjustment	Flow Change / Turn	0.7 GPM	2.6 LPM
	Maximum Torque	28 in.-lbs	3.2 Nm

► PERFORMANCE:

		HPVR-6	
Volumetric Displacement	cu. In./rev.	0.88	
	ml/rev.	14.4	
Pump Delivery @ 1750 RPG	GPM	6.67	
	LPM	25.2	
Operating Pressures	Intermittent*	PSI	4500
		BAR	310
	Continuous	PSI	4000
		BAR	276
	Minimum**	PSI	200
		BAR	14
Operating Speeds	Maximum RPM	see below	
	Rated RPM	1750	
	Minimum RPM	500	
Input Power @ 1750 RPM (Rated Flow and Pressure)	HP	18	
	kW	13.4	
Case Drain Flow @ Deadhead & Rated Pressure	GPM	0.3	
	LPM	1.1	
Mounting Flange		SAE Type	A 2-Bolt
Drive Shaft	Keyed Shaft	SAE J744C	0.75 in.
	Spline Shafts	SAE B	.8125 13 tooth
Shipping Weights	Rear Ports	lbs.	27
		kg	12.4
	Side Ports	lbs.	35
		kg	15.9

* This pressure should not exceed 10% of the duty cycle and not exceed 6 consecutive seconds.

** Pumps operating at less than 150 PSI (10 bar) may overheat and shorten pump life.

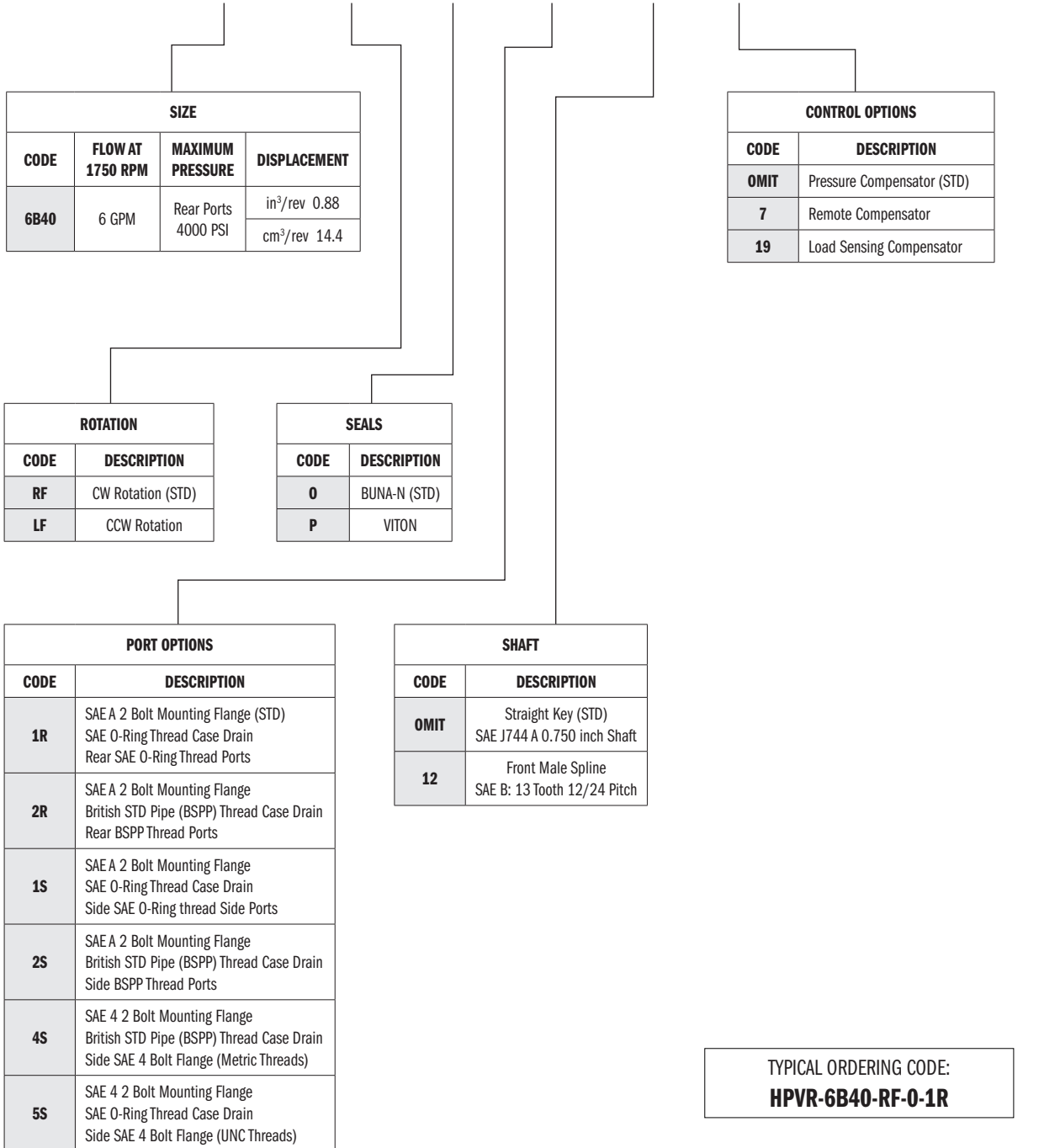
► HPVR-6 IDENTIFICATION CODE:
HPVR - - - - - - ——— DESIGN LETTER

See Dimensional Pages for Port Size and Code Type

► **HPVR-6 PERFORMANCE DATA:**

TABLES: Data taken at 1800 RPM

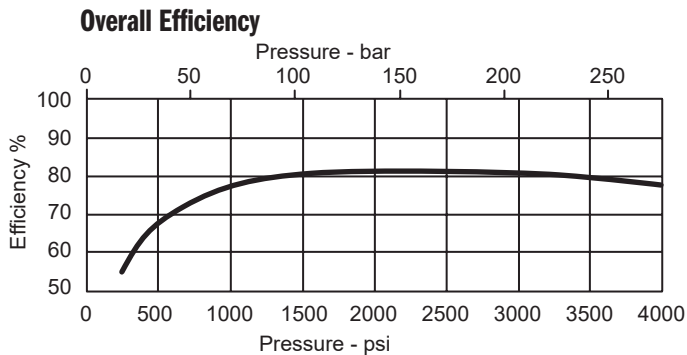
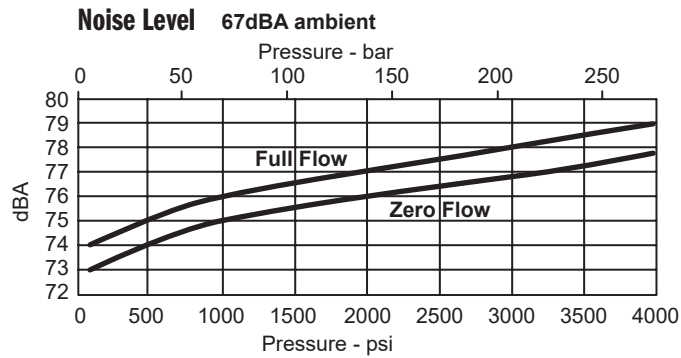
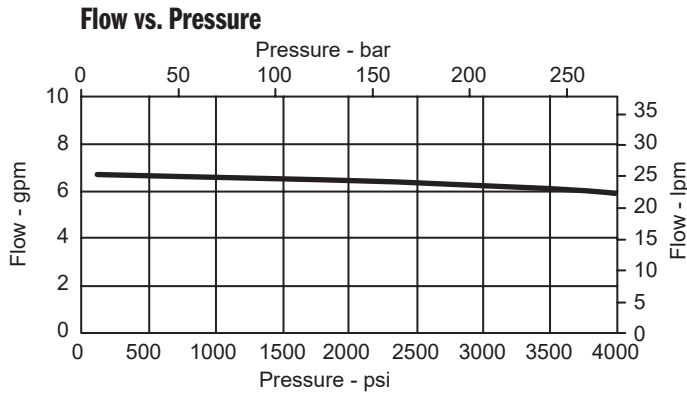
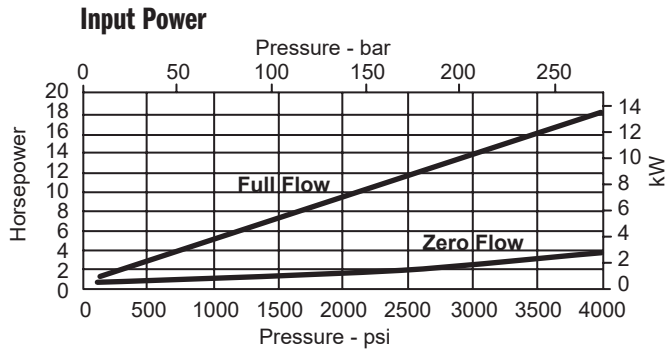

► **HPVR-6 INSTALLATION DATA:**

Dimensions:
inches (± .125")
millimeters (± 1 mm)

FEATURES: REAR PORT DIMENSIONS

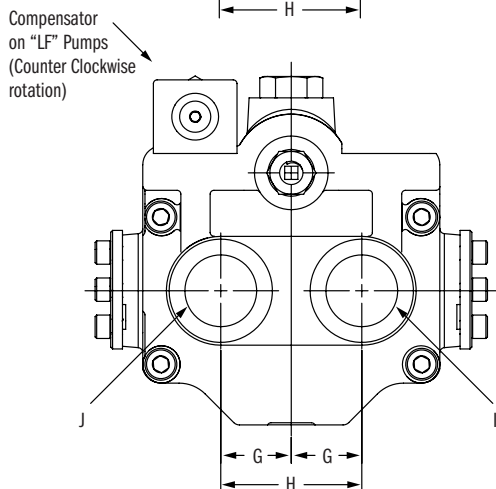
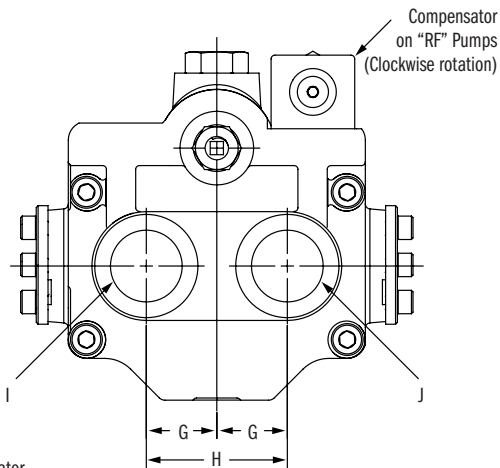
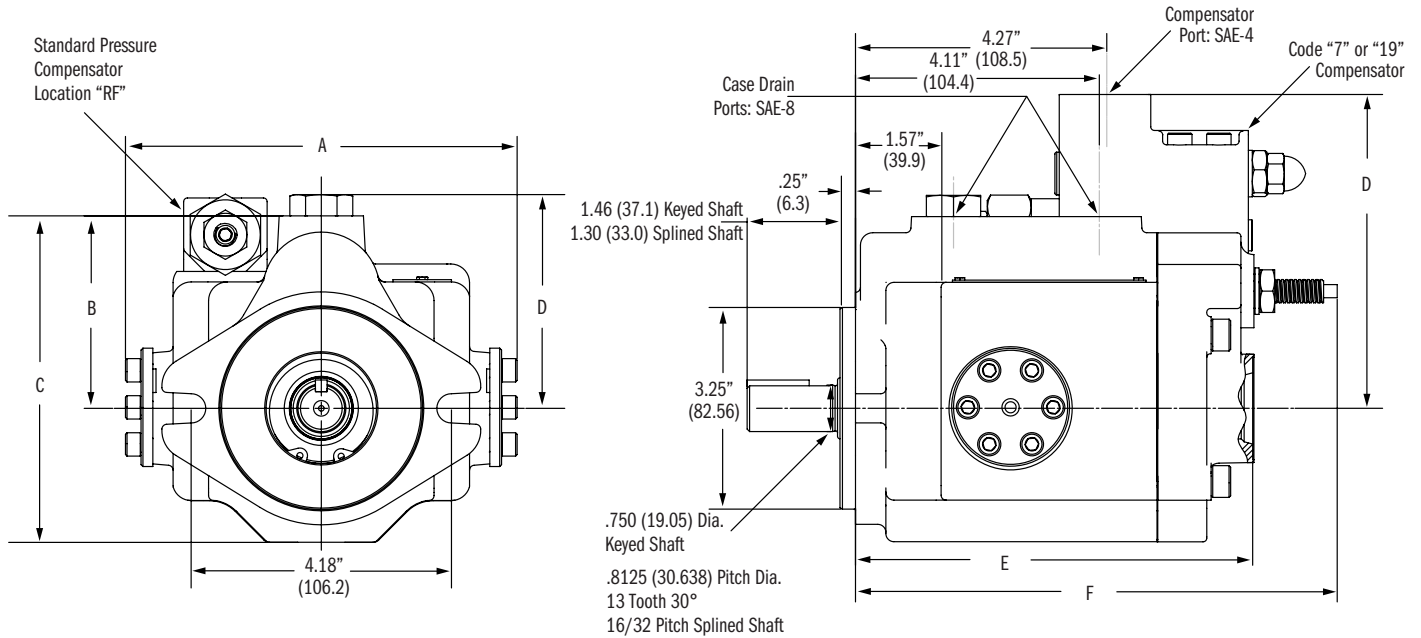

DIMENSIONAL REFERENCE DATA	Inch (mm)
A	6.29 (159.8)
B	3.09 (78.49)
C	5.24 (133.1)
D (STD Pressure Compensator)	3.43 (87.12)
D (Code 7 Remote & Code 19 Load Sense)	5.06 (128.5)
E	6.40 (162.5)
F	7.76 (197.1)
G	1.13 (28.7)
H	2.26 (57.4)
I/J Code 1R - Rear SAE Porting	SAE-12
I/J Code 2R - Rear BSPP Porting	3/4 BSPP

**NOTE: I = Inlet Port,
J = Outlet Port**

► **HPVR-6 INSTALLATION DATA:**

FEATURES: SIDE PORT DIMENSIONS

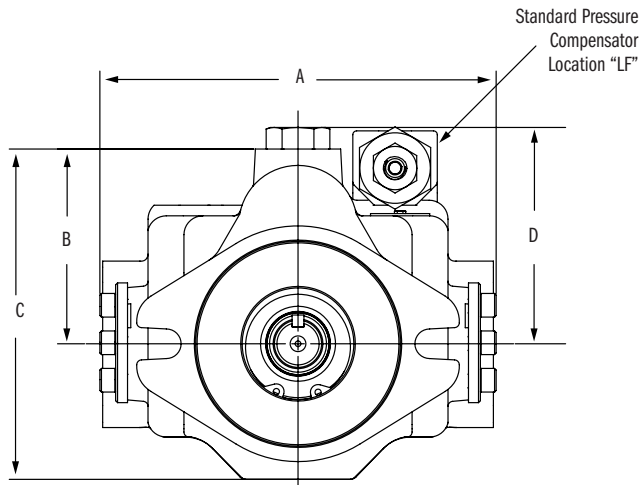
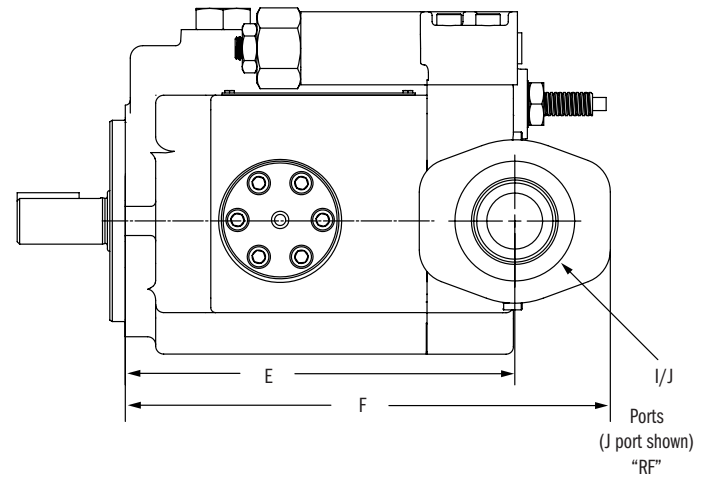
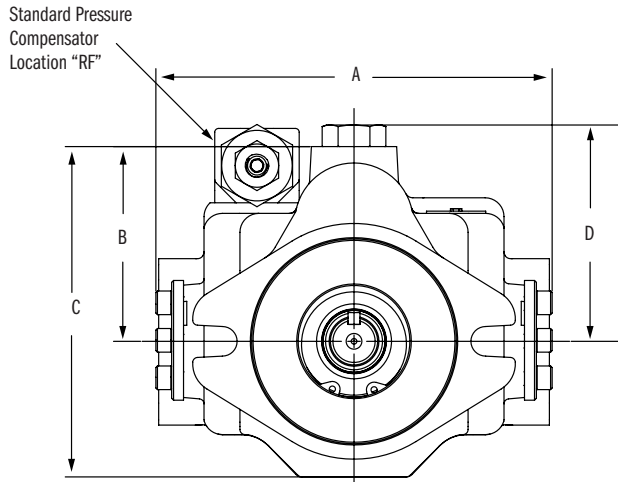

DIMENSIONAL REFERENCE DATA	Inch (mm)
A	6.29 (159.8)
B	3.09 (78.49)
C	5.24 (133.1)
D (STD Pressure Compensator)	3.43 (87.12)
D (Code 7 Remote & Code 19 Load Sense)	5.06 (128.5)
E	6.29 (159.8)
F	7.83 (198.9)
I Code 1S - Side SAE Porting	SAE-16
I Code 2S - Side BSPP Porting	1" BSPP
J Code 1S - Side SAE Porting	SAE-12
J Code 2S - Side BSPP Porting	3/4" BSPP
I Code 4S - 4 bolt Flange Metric thd.	1" S. F.
I Code 5S - bolt Flange UNC thd.	1" S. F.
J Code 4S - 4 bolt Flange Metric thd.	3/4" S. F.
J Code 5S - bolt Flange UNC thd.	3/4" S. F.

NOTE: Suction Flange Code 61, Pressure Flange Code 62

**NOTE: I = Inlet Port,
J = Outlet Port**

HPVR-10
Code 21 Tandem

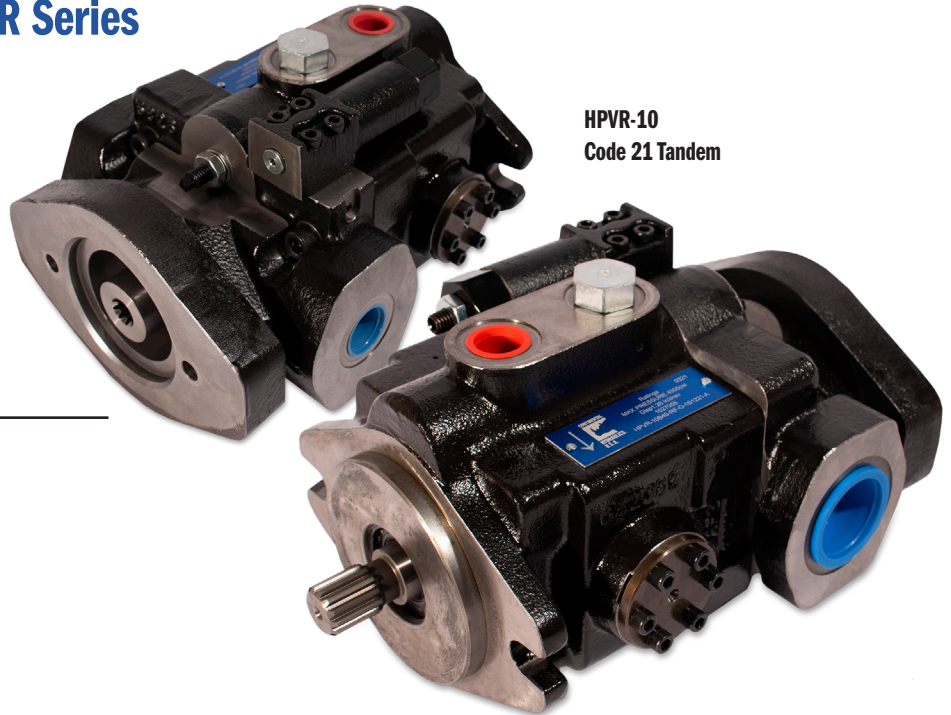

HPVR-10

Axial Piston Pumps

► SPECIFICATIONS:

CASE AND INLET PORT

Speed	Minimum Inlet Pressure						Maximum Case Pressure	
	Pressure Gauge				Absolute Pressure			
rpm	psi	bar	in.-Hg	mm-Hg	psi	bar	psi	bar
1800	-3	-0.21	-6.12	-155.46	11.7	0.81	10	0.69
2100	-3	-0.21	-6.12	-155.46	11.7	0.81	7	0.48
2500	-3	-0.21	-6.12	-155.46	11.7	0.81	5	0.34
2700	-1.03	-0.17	-2.1	-53.44	13.67	0.9	5	0.34
2800	0.00	0.00	0.00	0.00	14.7	1.01	5	0.34
3000	2.18	0.15	4.44	112.71	16.88	1.2	5	0.34

PRESSURE AND VOLUME ADJUSTMENT SENSITIVITY

Pressure Adjustment	Pressure Change / Turn	650 PSI	44.8 Bar
Volume Adjustment	Flow Change / Turn	1.2 GPM	4.5 LPM
	Maximum Torque	25 in.-lbs	2.8 Nm

► PERFORMANCE:

		HPVR-10	
Volumetric Displacement		cu. in./rev.	1.26
		ml/rev.	21.1
Pump Delivery @ 1750 RPG		GPM	9.9
		LPM	37.5
Operating Pressures	Intermittent*	PSI	4500
		BAR	310
	Continuous	PSI	4000
		BAR	276
Minimum**	PSI	200	
	BAR	14	
Operating Speeds	Maximum RPM	see below	
	Rated RPM	1750	
	Minimum RPM	500	
Input Power @ 1750 RPM (Rated Flow and Pressure)	HP	27	
	kW	20.1	
Case Drain Flow @ Deadhead & Rated Pressure	GPM	0.7	
	LPM	2.6	
Mounting Flange	SAE Type	B 2-Bolt	
Drive Shaft	Keyed Shaft	SAE J744C	0.875 in.
	Spline Shafts	SAE C	13 tooth
Shipping Weights	Rear Ports	lbs.	39
		kg	17.7
	Side Ports	lbs.	50
		kg	22.7
	Side Ports Tandem	lbs.	52
		kg	23.6

* This pressure should not exceed 10% of the duty cycle and not exceed 6 consecutive seconds.

** Pumps operating at less than 150 PSI (10 bar) may overheat and shorten pump life.

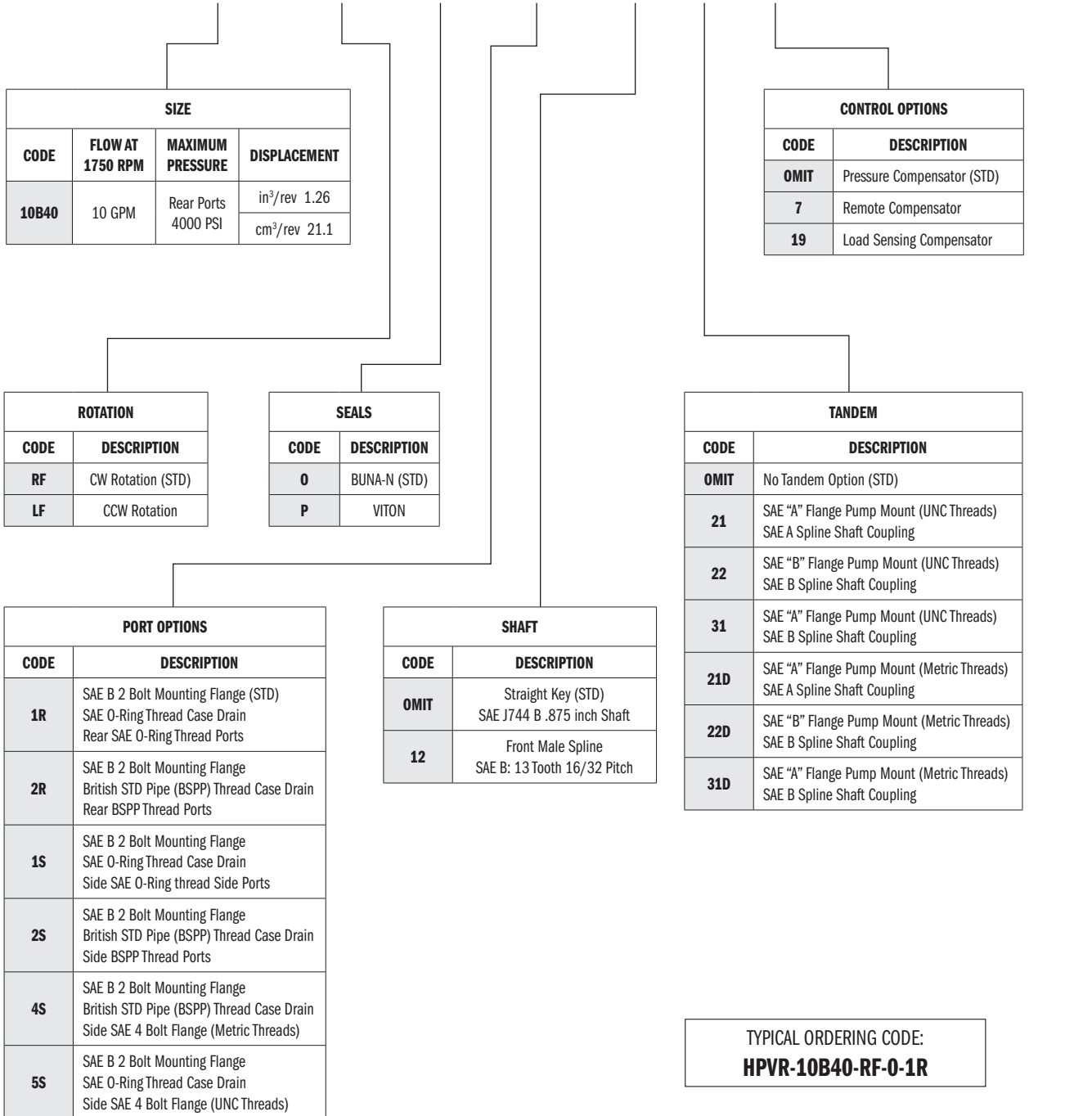
► HPVR-10 IDENTIFICATION CODE:
HPVR - [] - [] - [] - [] - [] [] [] - [] ——— DESIGN LETTER

See Dimensional Pages for Port Size and Code Type

► **HPVR-10 PERFORMANCE DATA:** TABLES: Data taken at 1800 RPM

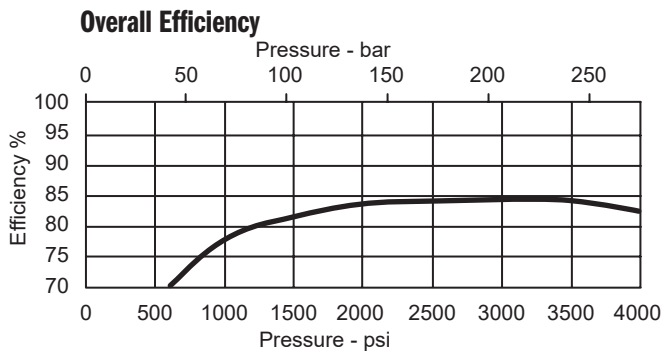
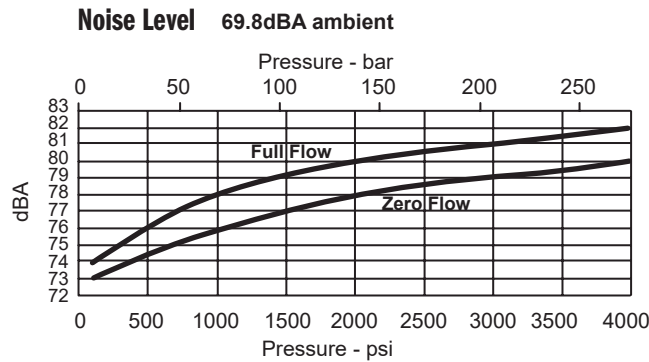
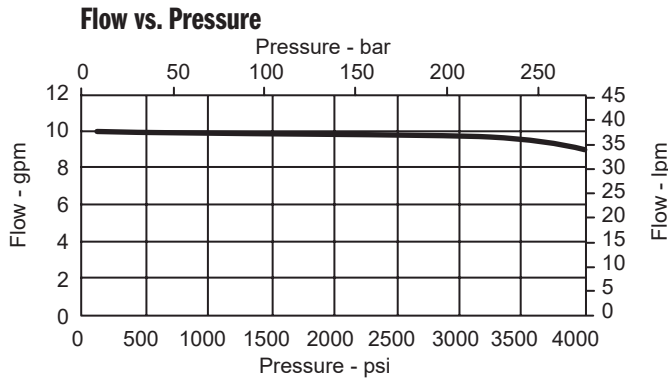
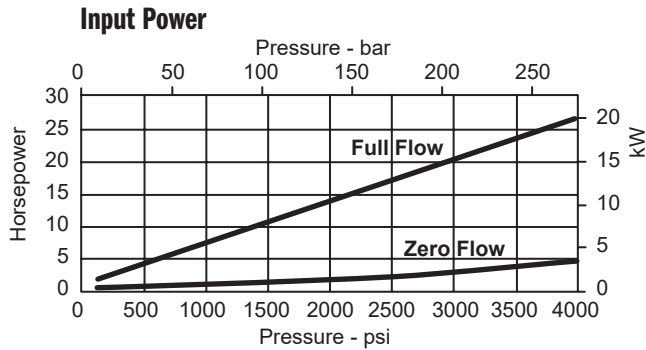

► **HPVR-10 INSTALLATION DATA:**

Dimensions:
inches (± .125")
millimeters (± 1 mm)

FEATURES: REAR PORT DIMENSIONS

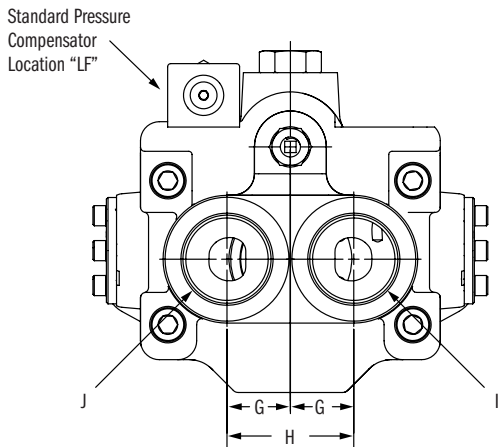
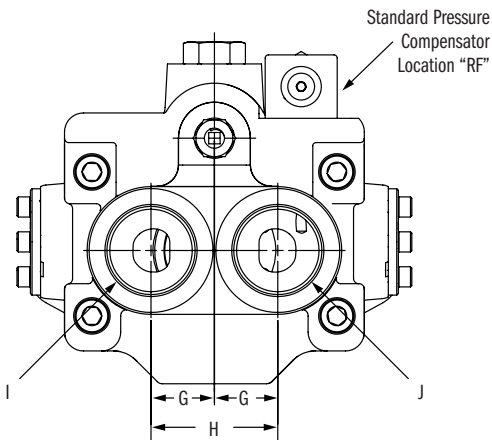
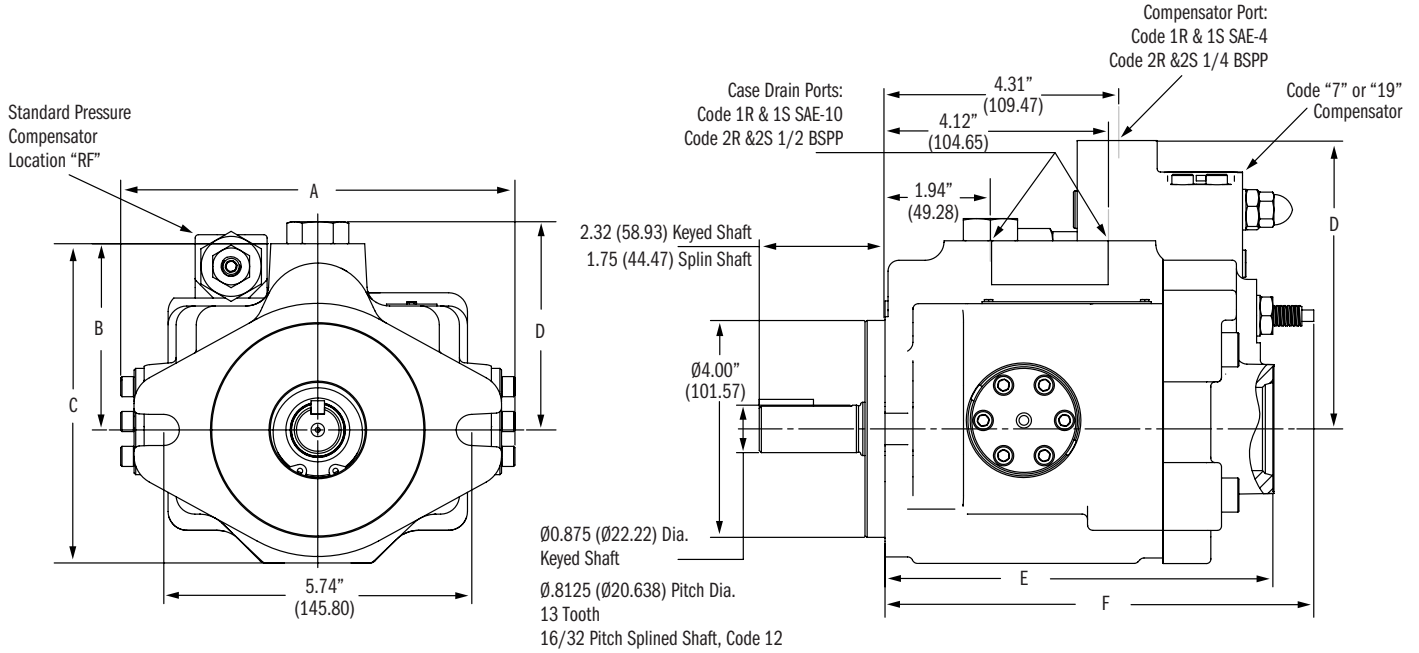

DIMENSIONAL REFERENCE DATA	Inch (mm)
A	7.35 (186.7)
B	3.45 (87.6)
C	5.93 (150.6)
D (STD Pressure Compensator)	3.90 (99.0)
D (Code 7 Remote & Code 19 Load Sense)	5.32 (135.1)
E	7.15 (181.6)
F	7.92 (201.2)
G	1.18 (29.9)
H	2.36 (59.9)
I Code 1R - Rear SAE Porting	SAE-20
I Code 2R - Rear BSPP Porting	1 1/4 BSPP
J Code 1R - Rear SAE Porting	SAE-20
J Code 2R - Rear BSPP Porting	1 1/4 BSPP

**NOTE: I = Inlet Port,
J = Outlet Port**

► **HPVR-10 INSTALLATION DATA:**

Dimensions:
inches (± .125")
millimeters (± 1 mm)

FEATURES: SIDE PORT DIMENSIONS

Standard Pressure
Compensator
Location "RF"

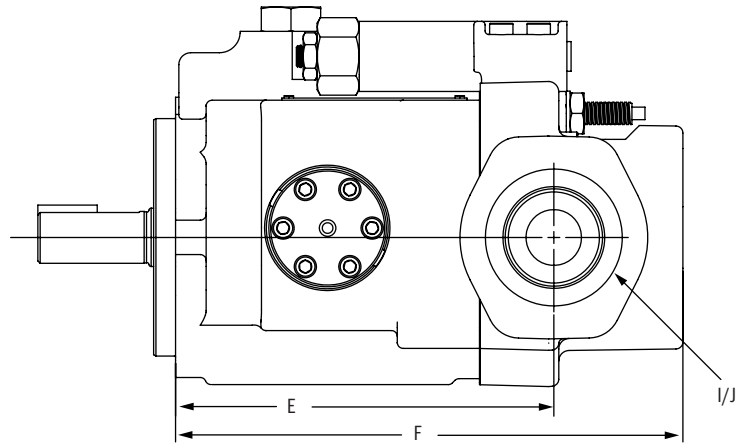
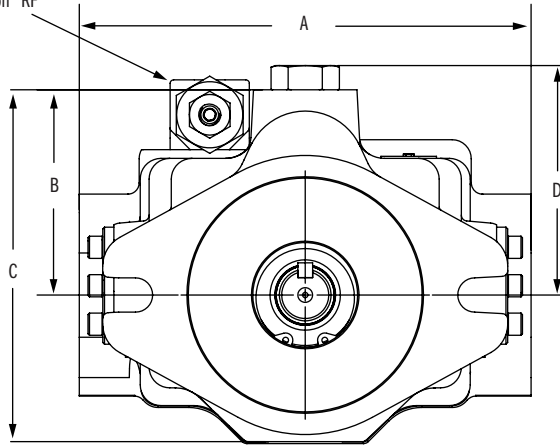

Standard Pressure
Compensator
Location "LF"

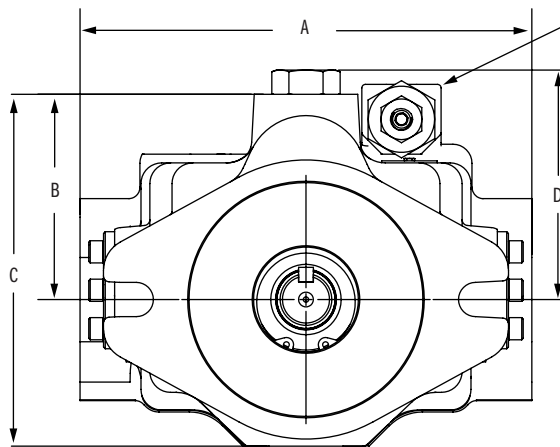

DIMENSIONAL REFERENCE DATA	Inch (mm)
A	7.64 (194)
B	3.47 (88.1)
C	5.95 (151)
D (STD Pressure Compensator)	3.88 (99)
D (Code 7 Remote & Code 19 Load Sense)	5.32 (135.1)
E	6.37 (161.8)
F	8.55 (217.2)
I Code 1S (SAE Ports)	SAE-20
I Code 2S (BSPP Ports)	1-1/4 BSPP
I Code 4S (4 Bolt Metric Ports)	1-1/4" SF
I Code 5S (4 Bolt UNC Ports)	1-1/4" SF
J Code 1S (SAE Ports)	SAE-12
J Code 2S (BSPP Ports)	3/4 BSPP
J Code 4S (4 Bolt Metric Ports)	3/4" SF
J Code 5S (4 Bolt UNC Ports)	3/4" SF

NOTE: Suction Flange Code 61, Pressure Flange Code 62

**NOTE: I = Inlet Port,
J = Outlet Port**

▶ HPVR-10 INSTALLATION DATA:

Dimensions:
inches (± .125")
millimeters (± 1 mm)

FEATURES: SIDE PORT DIMENSIONS

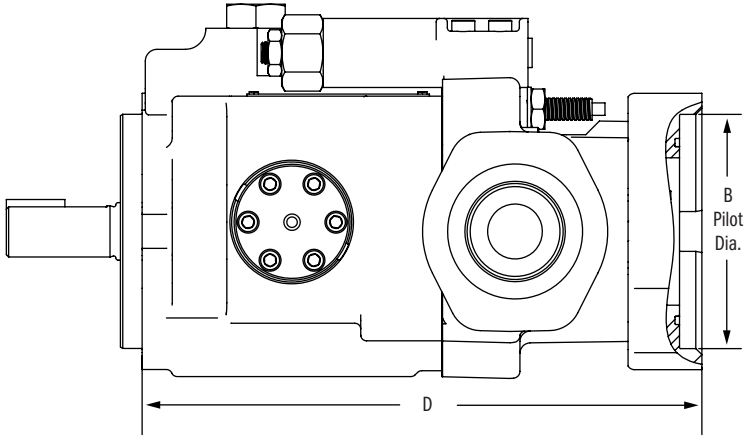
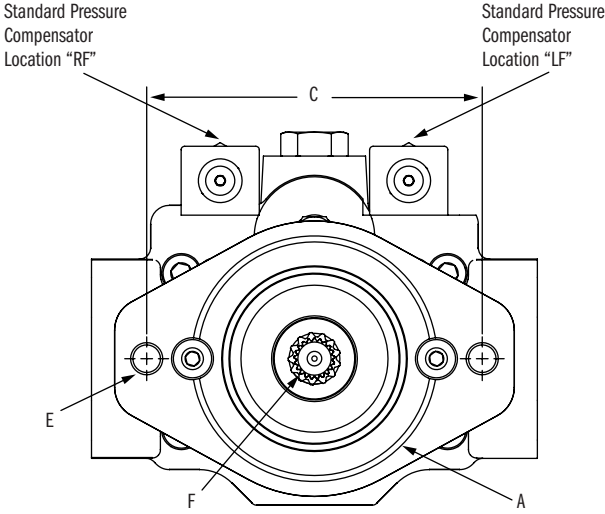

CODE	Mounting Pad	Dimensions inches (mm)				Thread	30° Involute Internal Spline	Maximum H.P. Rating* (at 175 RPM)	Maximum Torque Rating (in-lbs)
		A	B	C	D				
21	SAE "A"	3.25 (82.6)	4.18 (106.2)	9.40 (238.7)	3/8-16 UNC	9 Tooth 16/32 Pitch 0.5625 Dia.	8.5	306	
22	SAE "B"	4.00 (101.6)	5.75 (146.1)	9.56 (242.8)	1/2-13 UNC	13 Tooth 16/32 Pitch 0.8125 Dia.	16.8	586	
31	SAE "A"	3.25 (82.6)	4.18 (106.2)	9.56 (242.8)	3/8-16 UNC	13 Tooth 16/32 Pitch 0.8125 Dia.	16.8	586	
21D	SAE "A"	3.25 (82.6)	4.18 (106.2)	9.40 (238.7)	M10	9 Tooth 16/32 Pitch 0.5625 Dia.	8.5	306	
22D	SAE "B"	4.00 (101.6)	5.75 (146.1)	9.56 (242.8)	M12	13 Tooth 16/32 Pitch 0.8125 Dia.	16.8	586	
31D	SAE "A"	3.25 (82.6)	4.18 (106.2)	9.56 (242.8)	M10	13 Tooth 16/32 Pitch 0.8125 Dia.	16.8	586	

***This is the maximum horsepower or torque that can be transmitted through the shaft coupling to the rear pump.**

HPVR-15

Axial Piston Pumps



HPVR-15

► SPECIFICATIONS:

CASE AND INLET PORT

Speed	Minimum Inlet Pressure						Maximum Case Pressure	
	Pressure Gauge				Absolute Pressure			
rpm	psi	bar	in.-Hg	mm-Hg	psi	bar	psi	bar
1800	-3	-0.21	-6.12	-155.46	11.7	0.81	10	0.69
2100	-3	-0.21	-6.12	-155.46	11.7	0.81	7	0.48
2230	-3	-0.21	-6.12	-155.46	11.7	0.81	5	0.34
2275	-2.53	-0.17	-5.16	-130.95	12.17	0.84	5	0.34
2350	-1.71	-0.12	-3.49	-88.67	12.99	0.9	5	0.34
2500	0.00	0.00	0.00	0.00	14.7	1.01	5	0.34

PRESSURE AND VOLUME ADJUSTMENT SENSITIVITY

Pressure Adjustment	Pressure Change / Turn	650 PSI	44.8 Bar
Volume Adjustment	Flow Change / Turn	1.8 GPM	6.8 LPM
	Maximum Torque	41 in.-lbs	4.6 Nm

► PERFORMANCE:

			HPVR-15
Volumetric Displacement		cu. In./rev.	2.09
		ml/rev.	34.2
Pump Delivery @ 1750 RPG		GPM	16.6
		LPM	62.8
Operating Pressures	Intermittent*	PSI	4500
		BAR	310
	Continuous	PSI	4000
		BAR	275
	Minimum**	PSI	200
		BAR	14
Operating Speeds	Maximum RPM	see below	
	Rated RPM	1750	
	Minimum RPM	500	
Input Power @ 1750 RPM (Rated Flow and Pressure)	HP	42	
	kW	31.3	
Case Drain Flow @ Deadhead & Rated Pressure	GPM	0.95	
	LPM	3.6	
Mounting Flange	SAE Type	B 2-Bolt	
Drive Shaft	Keyed Shaft	SAE J744C	0.875 in.
	Spline Shafts	SAE C	.8125 13 tooth
Shipping Weights	Rear Ports	lbs.	51
		kg	23.2
	Side Ports	lbs.	63
		kg	28.6
	Side Ports Tandem	lbs.	69
		kg	31.3

* This pressure should not exceed 10% of the duty cycle and not exceed 6 consecutive seconds.

** Pumps operating at less than 150 PSI (10 bar) may overheat and shorten pump life.

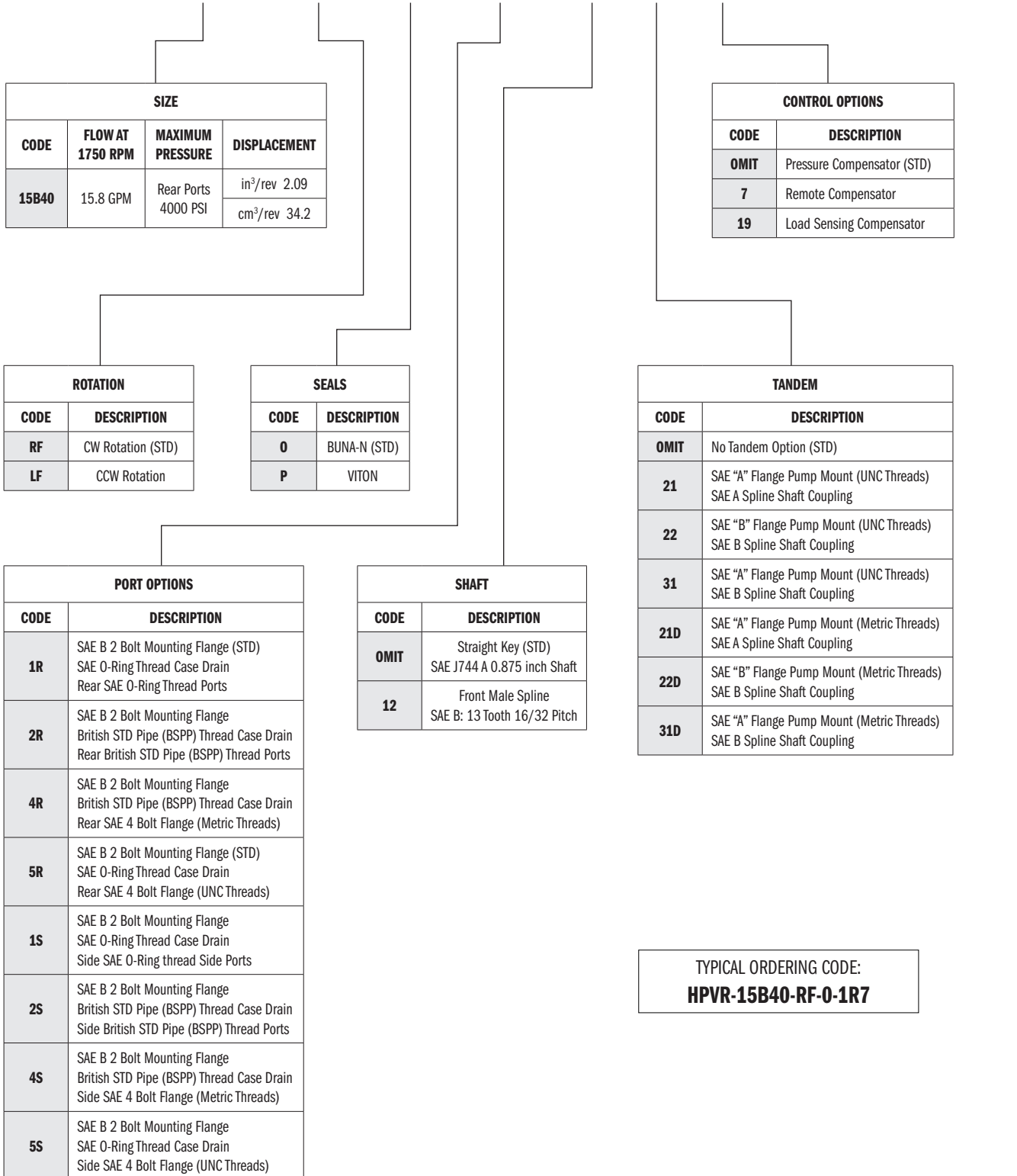
► HPVR-15 IDENTIFICATION CODE:
HPVR - [] - [] - [] - [] - [] [] [] - [] ——— DESIGN LETTER

TYPICAL ORDERING CODE:
HPVR-15B40-RF-O-1R7

See Dimensional Pages for Port Size and Code Type

► **HPVR-15 PERFORMANCE DATA:** TABLES: Data taken at 1800 RPM

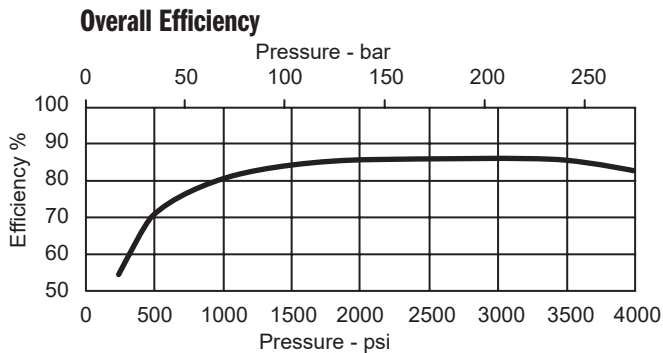
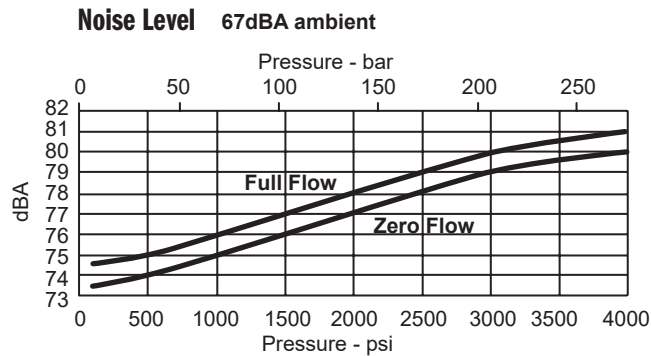
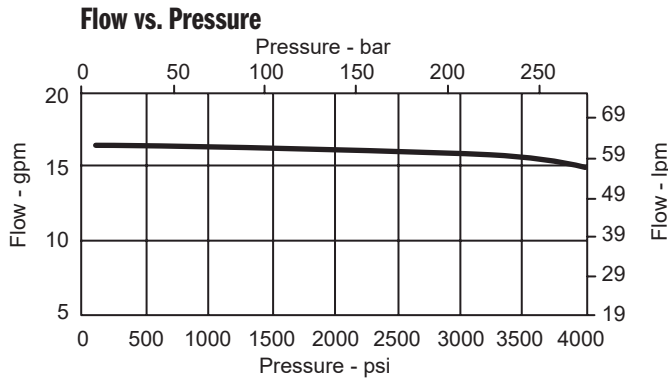
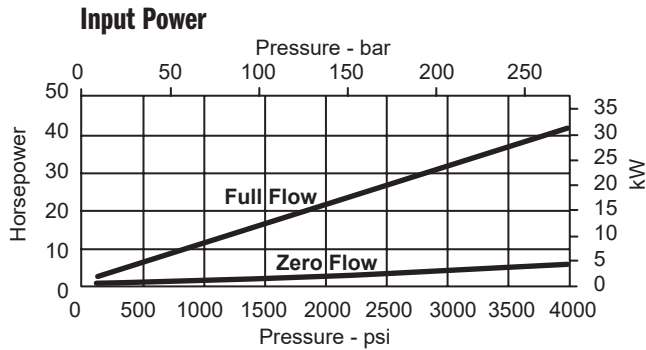

► **HPVR-15 INSTALLATION DATA:**

Dimensions:
inches (± .125")
millimeters (± 1 mm)

FEATURES: REAR PORT DIMENSIONS

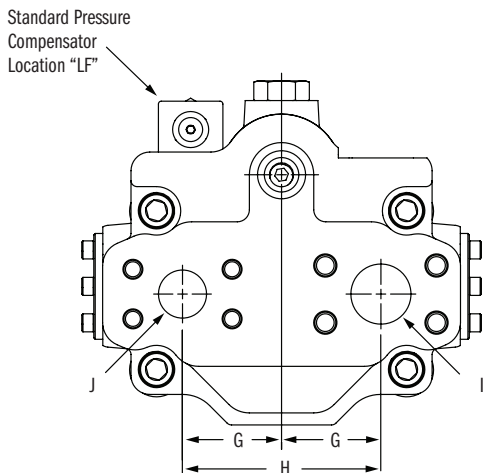
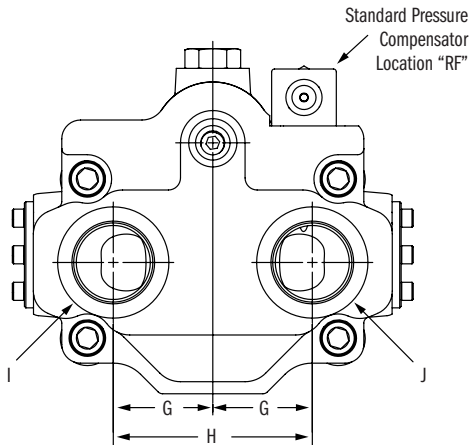
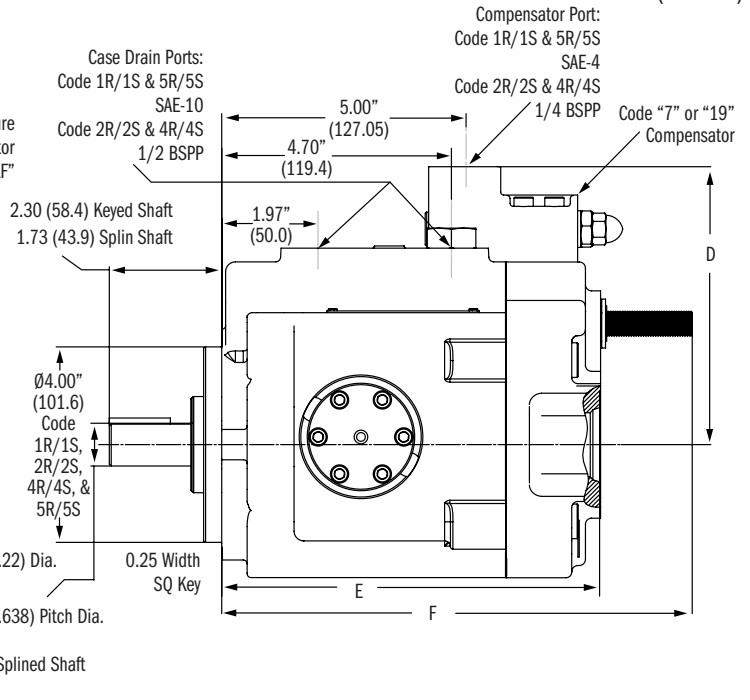
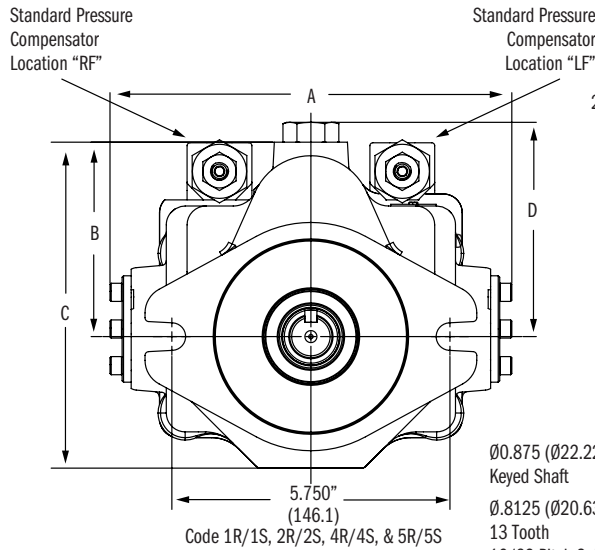

DIMENSIONAL REFERENCE DATA	Inch (mm)
A	8.31 (211.1)
B	4.02 (102.1)
C	6.74 (171.2)
D (STD Pressure Compensator)	4.45 (113.0)
D (Code 7 Remote & Code 19 Load Sense)	5.73 (145.5)
E	7.73 (196.3)
F	9.62 (244.3)
G	2.06 (52.4)
H	4.125 (104.8)
I/J Code 1R - Rear SAE Porting	SAE-20
I/J Code 2R - Rear BSPP Porting	1 1/4 BSPP
I Code 4R - Rear 4 Bolt Flange (Metric Threads)	1 1/4 SF
I Code 5R - Rear 4 Bolt Flange (UNC Threads)	1 1/4 SF
J Code 4R - Rear 4 Bolt Flange (Metric Threads)	1 SF
J Code 5R - Rear 4 Bolt Flange (UNC Threads)	1 SF

NOTE: Suction Flange Code 61, Pressure Flange Code 62

**NOTE: I = Inlet Port,
J = Outlet Port**

► **HPVR-15 INSTALLATION DATA:**

Dimensions:
inches (± .125")
millimeters (± 1 mm)

FEATURES: SIDE PORT DIMENSIONS

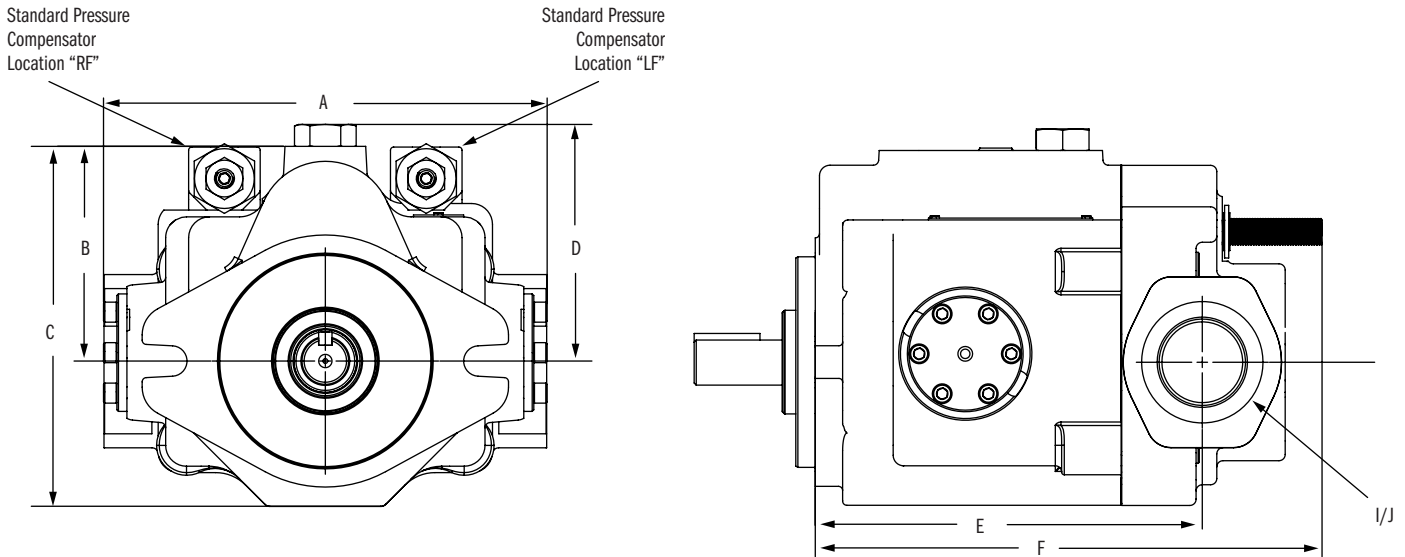

DIMENSIONAL REFERENCE DATA	Inch (mm)
A	8.31 (211.0)
B	4.02 (102.1)
C	6.74 (171.2)
D (STD Pressure Compensator)	4.43 (112.5)
D (Code 7 Remote & Code 19 Load Sense)	5.69 (144.5)
E	7.35 (186.7)
F	9.627 (244.5)
I/J Code 1S Side (SAE Ports)	SAE-20
I/J Code 2S Side (BSPP Ports)	1-1/4 BSPP
I Code 4S - Side 4 Bolt Flange (Metric Threads)	1-1/4 SF
I Code 5S - Side 4 Bolt Flange (UNC Threads)	1-1/4 SF
J Code 4S - Side 4 Bolt Flange (Metric Threads)	1 SF
J Code 5S - Side 4 Bolt Flange (UNC Threads)	1 SF

NOTE: Suction Flange Code 61, Pressure Flange Code 62

**NOTE: I = Inlet Port,
J = Outlet Port**

► **HPVR-15 INSTALLATION DATA:**

FEATURES: SIDE PORT DIMENSIONS

Dimensions:
inches (± .125")
millimeters (± 1 mm)

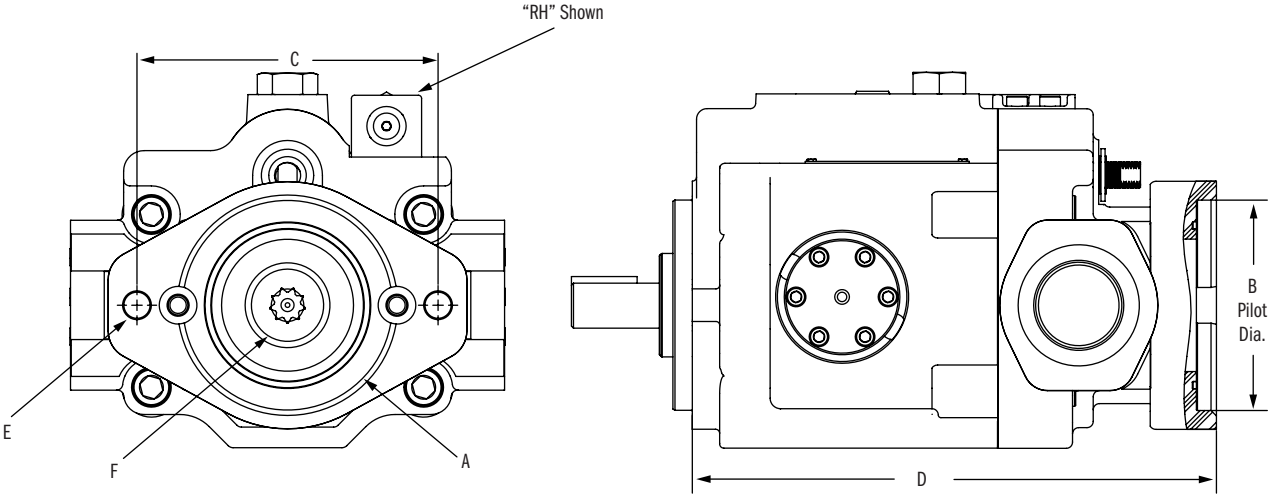

CODE	Mounting Pad	Dimensions inches (mm)				Thread	30° Involute Internal Spline	Maximum H.P. Rating* (at 175 RPM)	Maximum Torque Rating (in-lbs)
		A	B	C	D				
21	SAE "A"	3.25 (82.6)	4.18 (106.2)	9.81 (249.1)	3/8-16 UNC	9 Tooth 16/32 Pitch 0.5625 Dia.	8.5	306	
22	SAE "B"	4.00 (101.6)	5.75 (146.1)	9.97 (253.2)	1/2-13 UNC	13 Tooth 16/32 Pitch 0.8125 Dia.	28.1	1012	
31	SAE "A"	3.25 (82.6)	4.18 (106.2)	9.81 (249.1)	3/8-16 UNC	13 Tooth 16/32 Pitch 0.8125 Dia.	28.1	1012	
21D	SAE "A"	3.25 (82.6)	4.18 (106.2)	9.81 (249.1)	M10	9 Tooth 16/32 Pitch 0.5625 Dia.	8.5	306	
22D	SAE "B"	4.00 (101.6)	5.75 (146.1)	9.97 (253.2)	M12	13 Tooth 16/32 Pitch 0.8125 Dia.	28.1	1012	
31D	SAE "A"	3.25 (82.6)	4.18 (106.2)	9.81 (249.1)	M10	13 Tooth 16/32 Pitch 0.8125 Dia.	28.1	1012	

*This is the maximum horsepower or torque that can be transmitted through the shaft coupling to the rear pump.

HPVR-20

Axial Piston Pumps

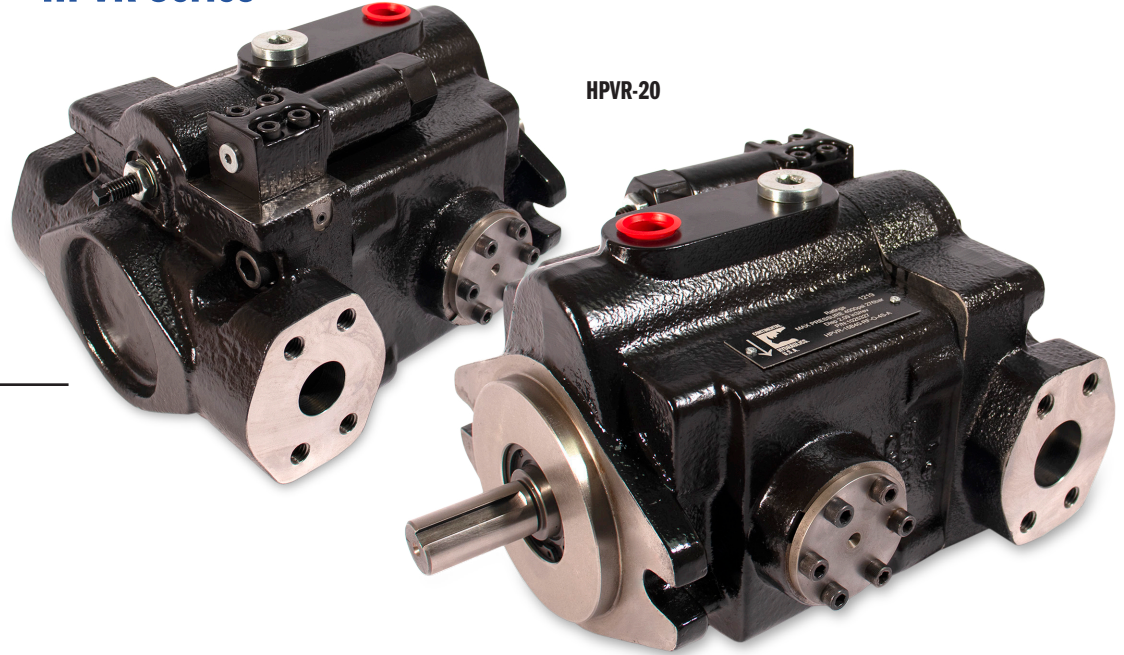

HPVR-20

► SPECIFICATIONS:

CASE AND INLET PORT

Speed	Minimum Inlet Pressure						Maximum Case Pressure	
	Pressure Gauge				Absolute Pressure			
rpm	psi	bar	in.-Hg	mm-Hg	psi	bar	psi	bar
1800	-3	-0.21	-6.12	-155.46	11.7	0.81	10	0.69
2050	-3	-0.21	-6.12	-155.46	11.7	0.81	7	0.48
2100	-2.45	-0.17	-6.12	-126.72	12.25	0.8	5	0.34
2200	-1.25	-0.09	-5.16	-64.8	13.45	0.9	5	0.34
2300	0.00	0.00	0.00	0.00	14.7	1.01	5	0.34
2400	1.31	0.09	2.66	67.88	16.08	1.1	5	0.34

PRESSURE AND VOLUME ADJUSTMENT SENSITIVITY

Pressure Adjustment	Pressure Change / Turn	650 PSI	44.8 Bar
Volume Adjustment	Flow Change / Turn	2.1 GPM	7.9 LPM
	Maximum Torque	49 in.-lbs	5.5 Nm

► PERFORMANCE:

		HPVR-20	
Volumetric Displacement		cu. In./rev.	2.62
		ml/rev.	42.9
Pump Delivery @ 1750 RPG		GPM	19.85
		LPM	75.03
Operating Pressures	Intermittent*	PSI	4500
		BAR	310
	Continuous	PSI	4000
		BAR	275
	Minimum**	PSI	200
		BAR	14
Operating Speeds	Maximum RPM	see below	
	Rated RPM	1750	
	Minimum RPM	500	
Input Power @ 1750 RPM (Rated Flow and Pressure)		HP	53
		kW	39.5
Case Drain Flow @ Deadhead & Rated Pressure		GPM	1.6
		LPM	6.1
Mounting Flange	SAE Type	C 2-Bolt	
Drive Shaft	Keyed Shaft	SAE J744C	1.25 in.
	Spline Shafts	SAE C	14 tooth
Shipping Weights	Rear Ports	lbs.	75
		kg	34
	Side Ports	lbs.	90
		kg	41
	Side Ports Tandem	lbs.	100
		kg	45.5

* This pressure should not exceed 10% of the duty cycle and not exceed 6 consecutive seconds.

** Pumps operating at less than 150 PSI (10 bar) may overheat and shorten pump life.

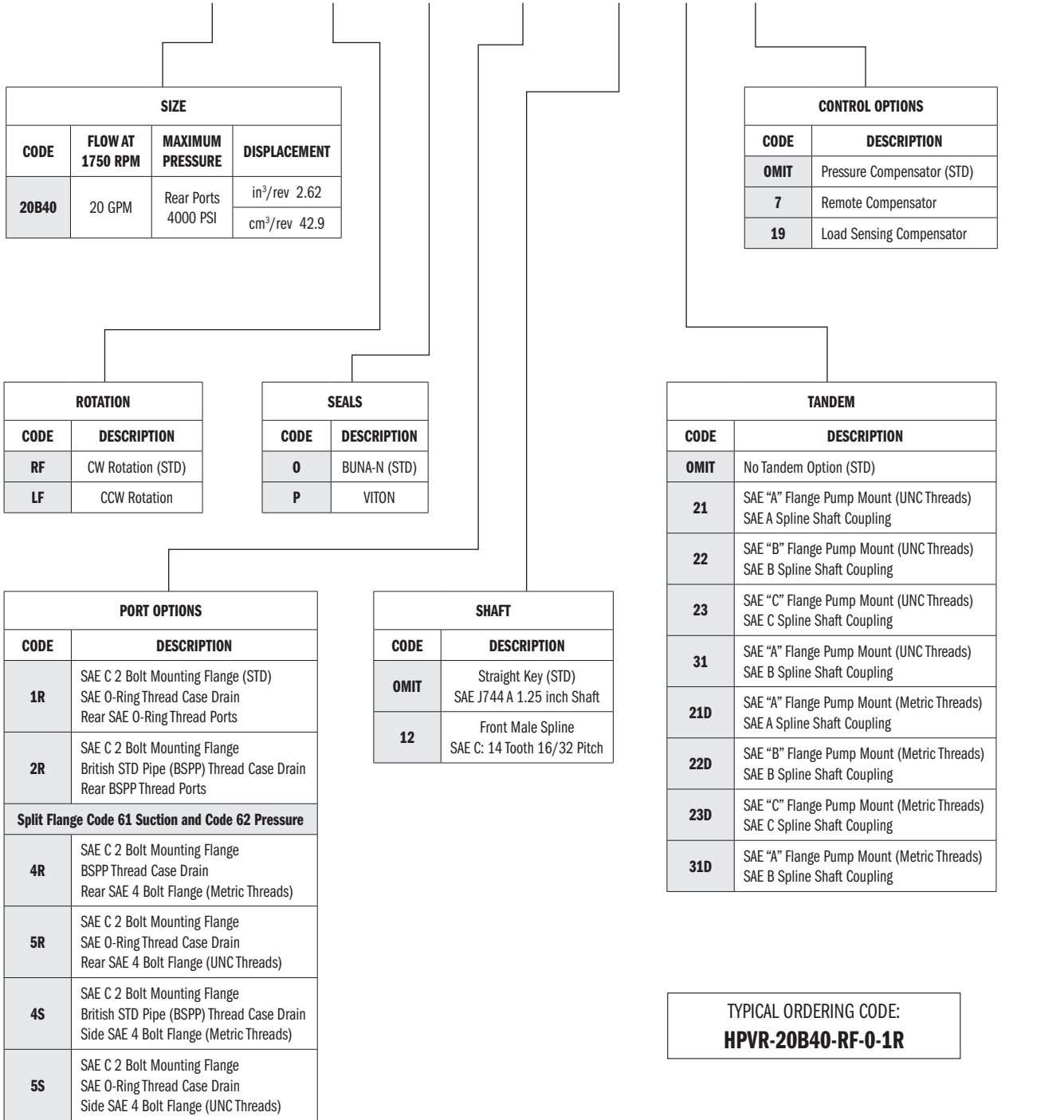
► HPVR-20 IDENTIFICATION CODE:
HPVR - - - - - - - - - - - ——— DESIGN LETTER

See Dimensional Pages for Port Size and Code Type

► **HPVR-20 PERFORMANCE DATA:** TABLES: Data taken at 1800 RPM

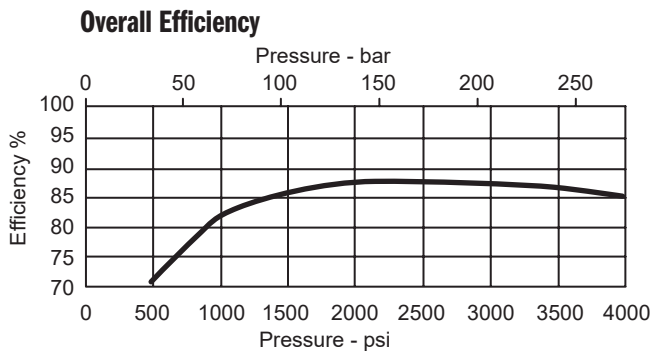
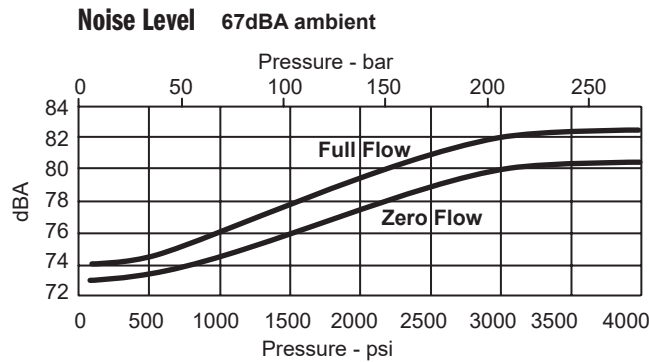
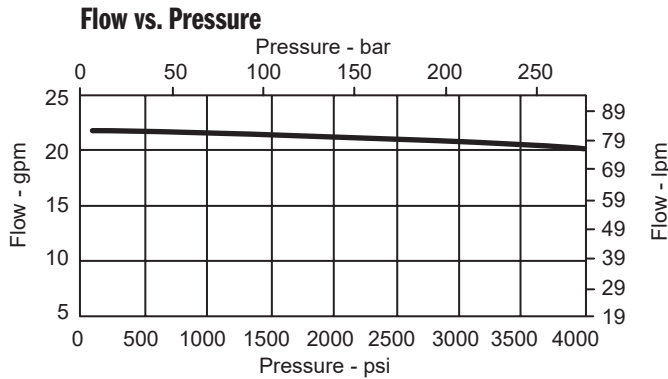
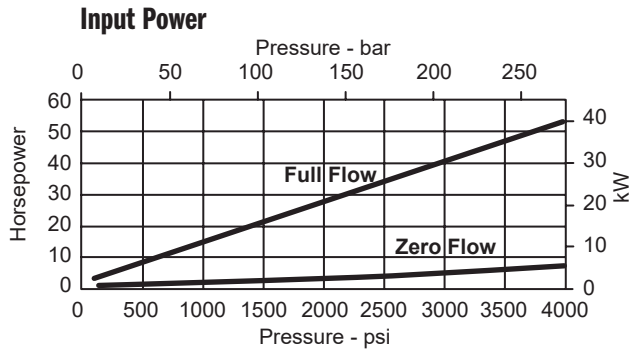

► **HPVR-20 INSTALLATION DATA:**

Dimensions:
inches (± .125")
millimeters (± 1 mm)

FEATURES: REAR PORT DIMENSIONS

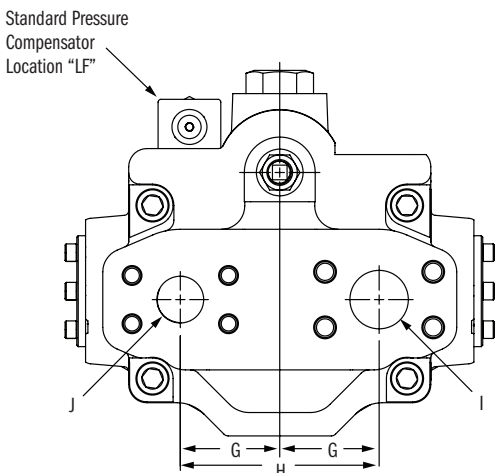
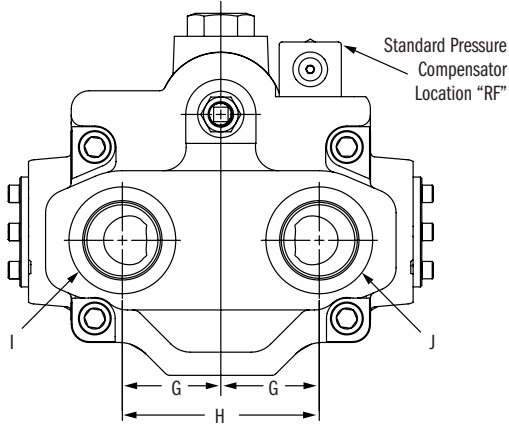
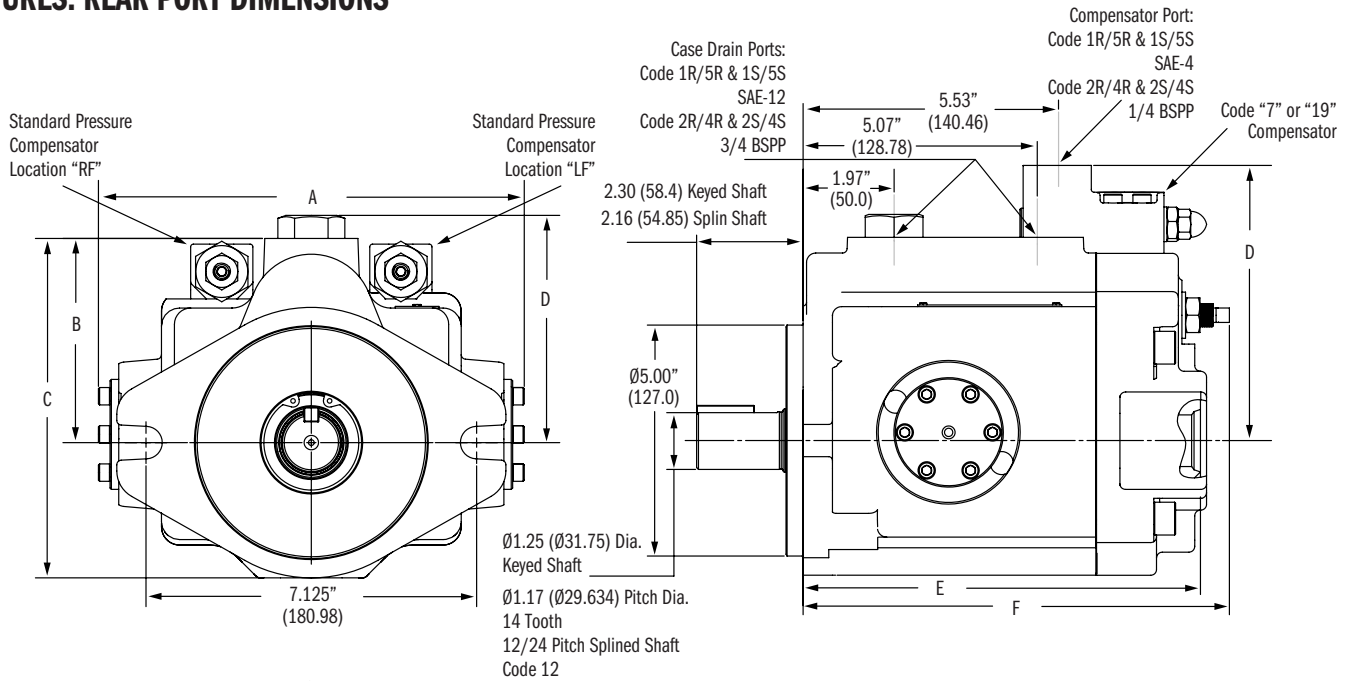

DIMENSIONAL REFERENCE DATA	Inch (mm)
A	9.18 (233.2)
B	4.40 (111.8)
C	7.32 (185.9)
D (STD Pressure Compensator)	4.90 (124.4)
D (Code 7 Remote & Code 19 Load Sense)	5.96 (151.4)
E	8.60 (218.4)
F	9.23 (234.4)
G	2.125 (53.9)
H	4.25 (107.9)
I Code 1R - Rear SAE Porting	SAE-20
I Code 2R - Rear BSPP Porting	1-1/4 BSPP
I Code 4R - Rear 4 Bolt Flange (Metric Threads)	1-1/4 SF
I Code 5R - Rear 4 Bolt Flange (UNC Threads)	1-1/4 SF
J Code 1R - Rear SAE Porting	SAE-20
J Code 2R - Rear BSPP Porting	1-1/4 BSPP
J Code 4R - Rear 4 Bolt Flange (Metric Threads)	1 SF
J Code 5R - Rear 4 Bolt Flange (UNC Threads)	1 SF

NOTE: Suction Flange Code 61, Pressure Flange Code 62

**NOTE: I = Inlet Port,
J = Outlet Port**

► **HPVR-20 INSTALLATION DATA:**

Dimensions:
inches (± .125")
millimeters (± 1 mm)

FEATURES: SIDE PORT DIMENSIONS

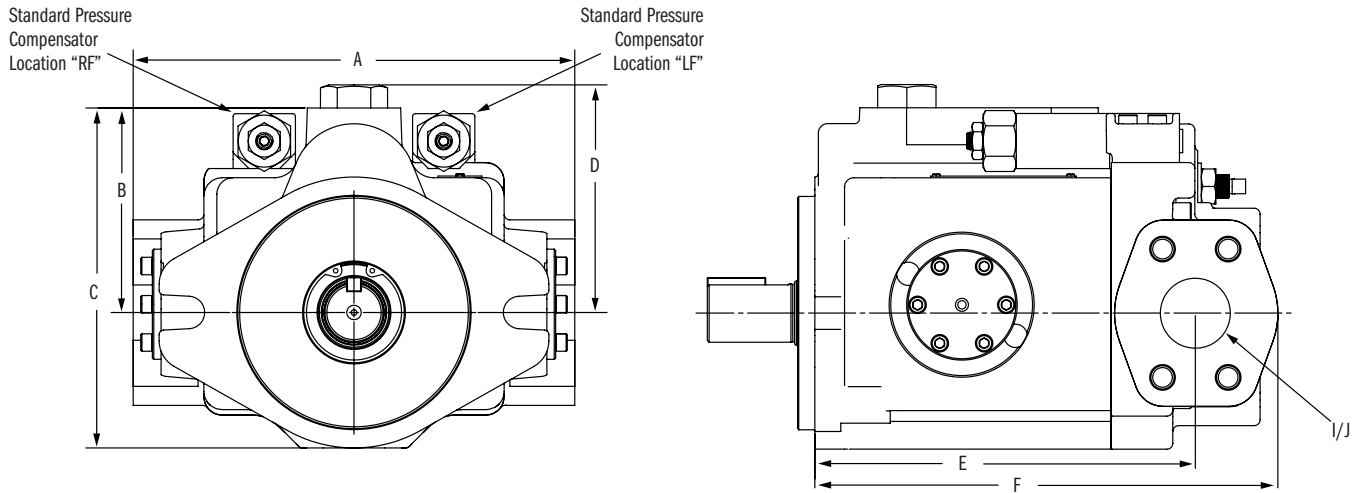

DIMENSIONAL REFERENCE DATA	Inch (mm)
A	9.50 (241.3)
B	4.40 (111.7)
C	7.32 (185.9)
D (STD Pressure Compensator)	4.90 (124.4)
D (Code 7 Remote & Code 19 Load Sense)	5.96 (151.4)
E	8.15 (207.0)
F	9.92 (251.9)
I Code 4S - Side 4 Bolt Flange (Metric Threads)	1-1/2 SF
I Code 5S - Side 4 Bolt Flange (UNC Threads)	1-1/2 SF
J Code 4S - Side 4 Bolt Flange (Metric Threads)	1 SF
J Code 5S - Side 4 Bolt Flange (UNC Threads)	1 SF

NOTE: Suction Flange Code 61, Pressure Flange Code 62

**NOTE: I = Inlet Port,
J = Outlet Port**

► HPVR-20 INSTALLATION DATA:
FEATURES: SIDE PORT DIMENSIONS

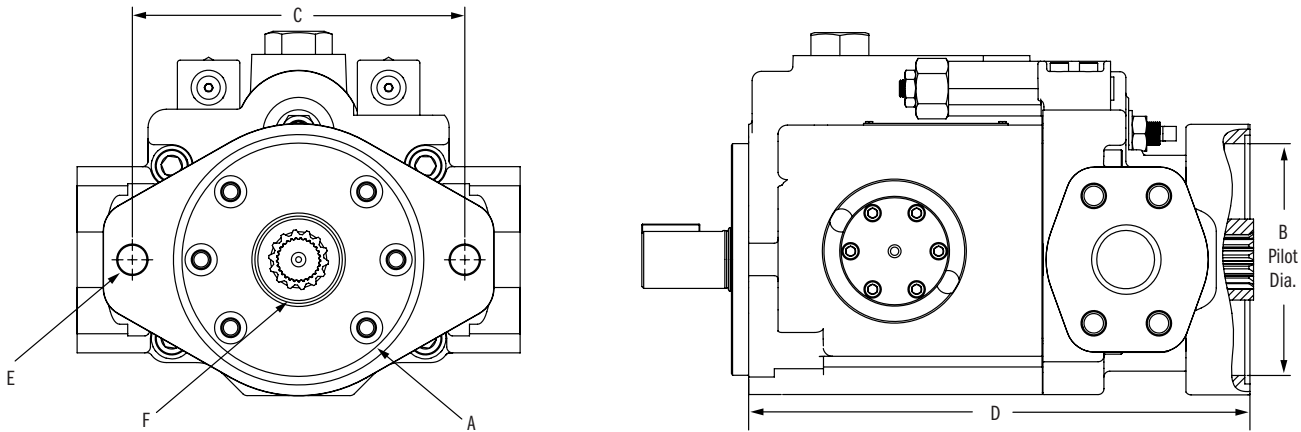
 Dimensions:
 inches (± .125")
 millimeters (± 1 mm)

CODE	Mounting Pad	Dimensions inches (mm)			Thread	30° Involute Internal Spline	Maximum H.P. Rating* (at 175 RPM)	Maximum Torque Rating (in-lbs)
		A	B	C				
21	SAE "A"	3.25 (82.6)	4.18 (106.2)	10.54 (267.7)	3/8-16 UNC	9 Tooth 16/32 Pitch 0.5625 Dia.	8.5	306
22	SAE "B"	4.00 (101.6)	5.75 (146.1)	10.70 (271.8)	1/2-13 UNC	13 Tooth 16/32 Pitch 0.8125 Dia.	16.8	586
23	SAE "C"	5.00 (127.0)	7.13 (181.1)	10.82 (274.8)	5/8-11 UNC	14 Tooth 12/24 Pitch 1.1667 Dia.	43.8	1577
31	SAE "A"	3.25 (82.6)	4.18 (106.2)	10.54 (267.7)	3/8-16 UNC	13 Tooth 16/32 Pitch 0.8125 Dia.	16.8	586
21D	SAE "A"	3.25 (82.6)	4.18 (106.2)	10.54 (267.7)	M10	9 Tooth 16/32 Pitch 0.5625 Dia.	8.5	306
22D	SAE "B"	4.00 (101.6)	5.75 (146.1)	10.70 (271.8)	M12	13 Tooth 16/32 Pitch 0.8125 Dia.	16.8	586
23D	SAE "C"	5.00 (127.0)	7.13 (181.1)	10.82 (274.8)	M16	14 Tooth 12/24 Pitch 1.1667 Dia.	43.8	1577
31D	SAE "A"	3.25 (82.6)	4.18 (106.2)	10.54 (267.7)	M10	13 Tooth 16/32 Pitch 0.8125 Dia.	16.8	586

*This is the maximum horsepower or torque that can be transmitted through the shaft coupling to the rear pump.

HPVR-29

Axial Piston Pumps

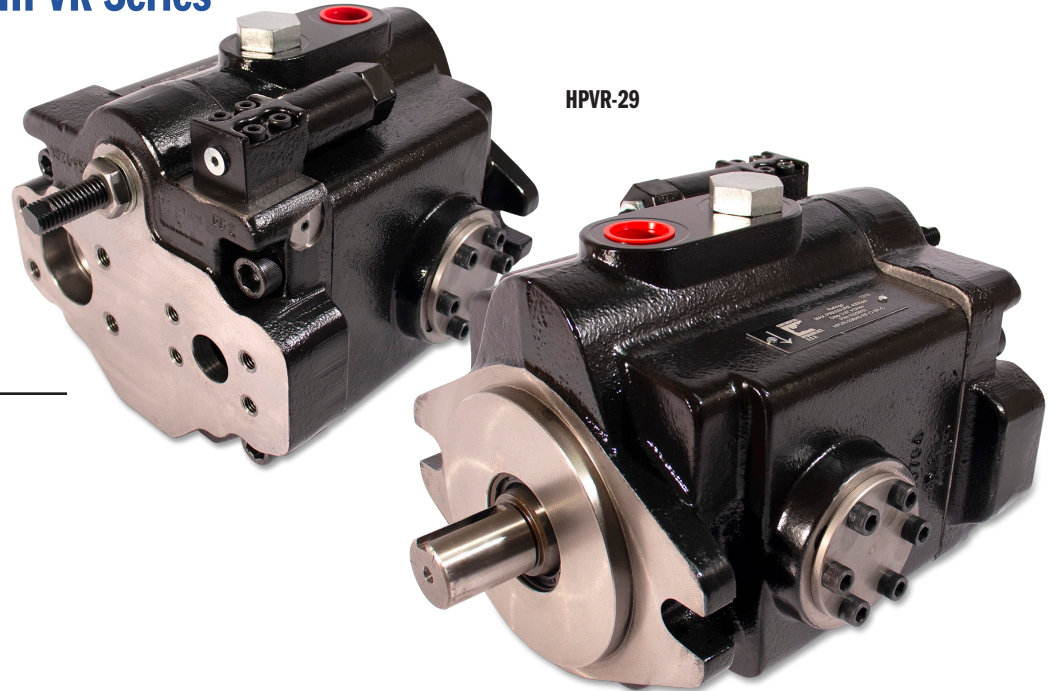

HPVR-29

► SPECIFICATIONS:

CASE AND INLET PORT

Speed	Minimum Inlet Pressure						Maximum Case Pressure	
	Pressure Gauge				Absolute Pressure			
rpm	psi	bar	in.-Hg	mm-Hg	psi	bar	psi	bar
1800	-3	-0.21	-6.12	-155.46	11.7	0.8	10	0.69
2050	-3	-0.21	-6.12	-155.46	11.7	0.81	7	0.48
2100	-2.45	-0.17	-4.99	-126.72	12.25	0.8	5	0.34
2200	-1.25	-0.09	-2.55	-64.8	13.45	0.9	5	0.34
2300	0	0	0	0	14.7	1	5	0.34
2400	1.31	0.09	2.66	67.88	16.01	1.1	5	0.34

PRESSURE AND VOLUME ADJUSTMENT SENSITIVITY

Pressure Adjustment	Pressure Change / Turn	650 PSI	44.8 Bar
Volume Adjustment	Flow Change / Turn	2.8 GPM	10.6 LPM
	Maximum Torque	45 in.-lbs	5.1 Nm

► PERFORMANCE:

		HPVR-29	
Volumetric Displacement	cu. in./rev.	3.97	
	ml/rev.	65	
Pump Delivery @ 1750 RPG	GPM	29	
	LPM	109.8	
Operating Pressures	Intermittent*	PSI	4500
		BAR	310
	Continuous***	PSI	4000
		BAR	275
	Minimum**	PSI	200
		BAR	14
Operating Speeds	Maximum RPM	see below	
	Rated RPM	1750	
	Minimum RPM	500	
Input Power @ 1750 RPM (Rated Flow and Pressure)	HP	82	
	kW	62	
Case Drain Flow @ Deadhead & Rated Pressure	GPM	1.9	
	LPM	7.2	
Mounting Flange	SAE Type	C 2-Bolt	
Drive Shaft	Keyed Shaft	SAE J744C	1.25 in.
	Spline Shafts	SAE C	14 tooth
Shipping Weights	Rear Ports	lbs.	75
		kg	34
	Side Ports	lbs.	90
		kg	41
	Side Ports Tandem	lbs.	100
		kg	45.5

* This pressure should not exceed 10% of the duty cycle and not exceed 6 consecutive seconds.

** Pumps operating at less than 150 PSI (10 bar) may overheat and shorten pump life.

*** Side port options 3500 PSI Continuous.

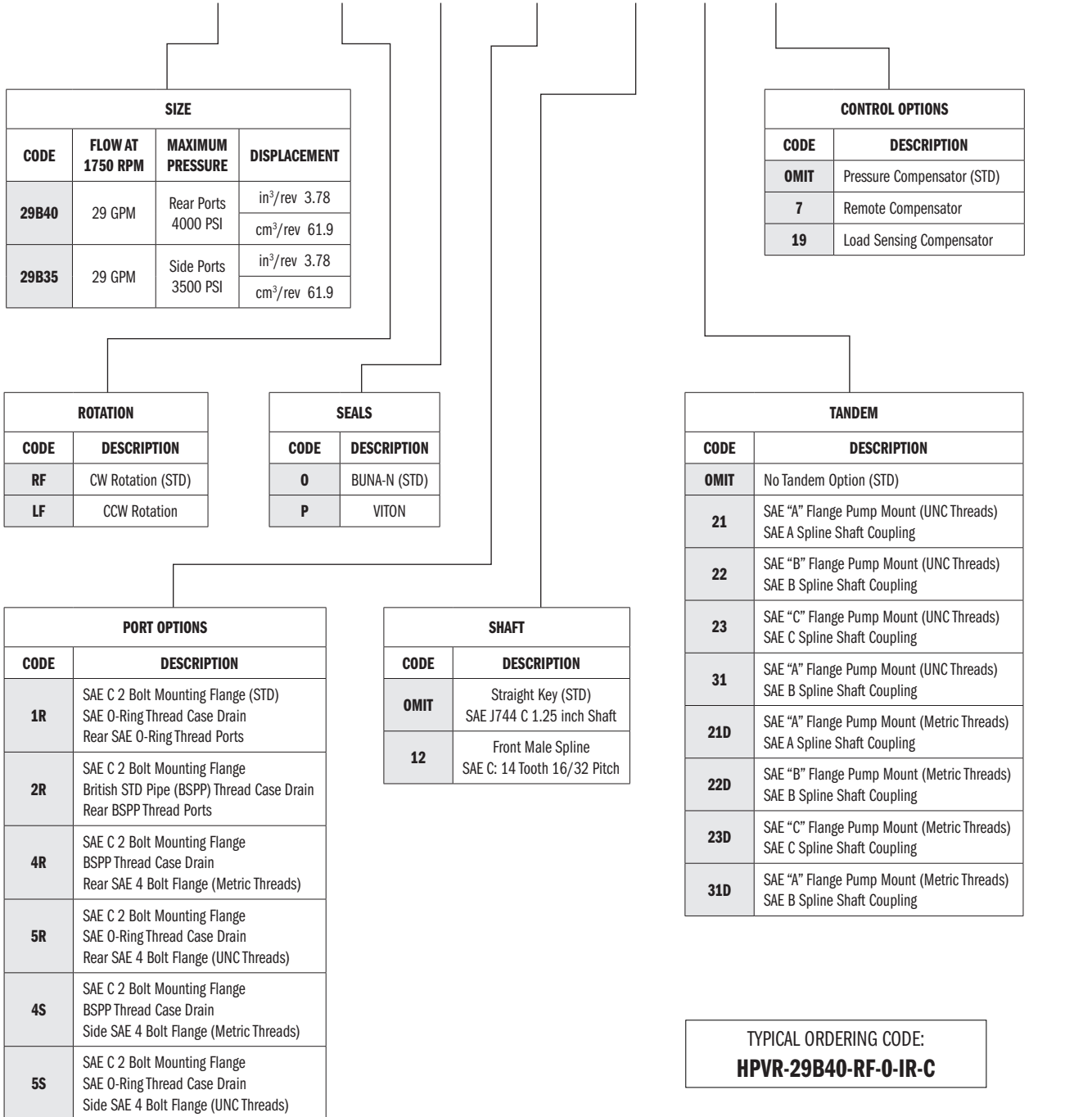
► HPVR-29 IDENTIFICATION CODE:
HPVR - [] - [] - [] - [] - [] [] [] - [] ——— DESIGN LETTER

 See Dimensional Pages for
 Port Size and Code Type

► **HPVR-29 PERFORMANCE DATA:** TABLES: Data taken at 1800 RPM

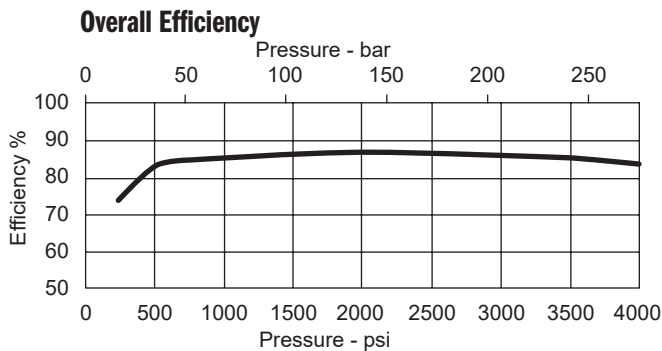
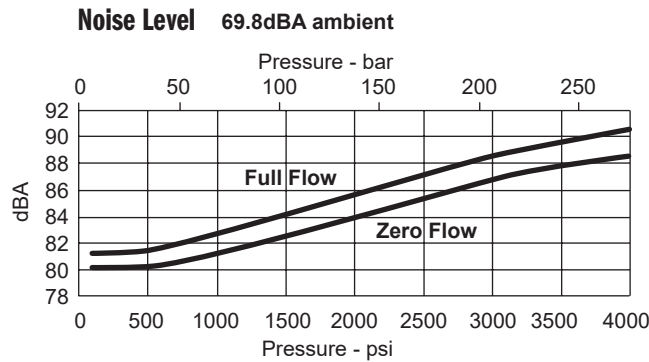
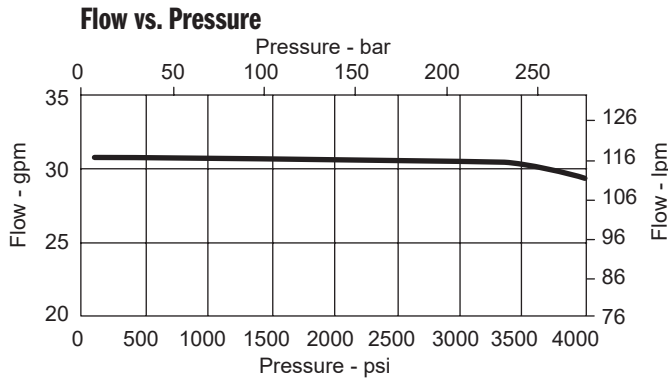
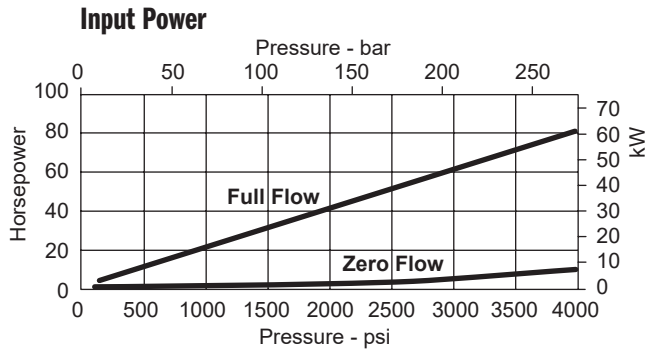
NOTE: Side port options maximum pressure is 3500 PSI



► **HPVR-29 INSTALLATION DATA:**

FEATURES: REAR PORT DIMENSIONS

Dimensions:
inches (± .125")
millimeters (± 1 mm)

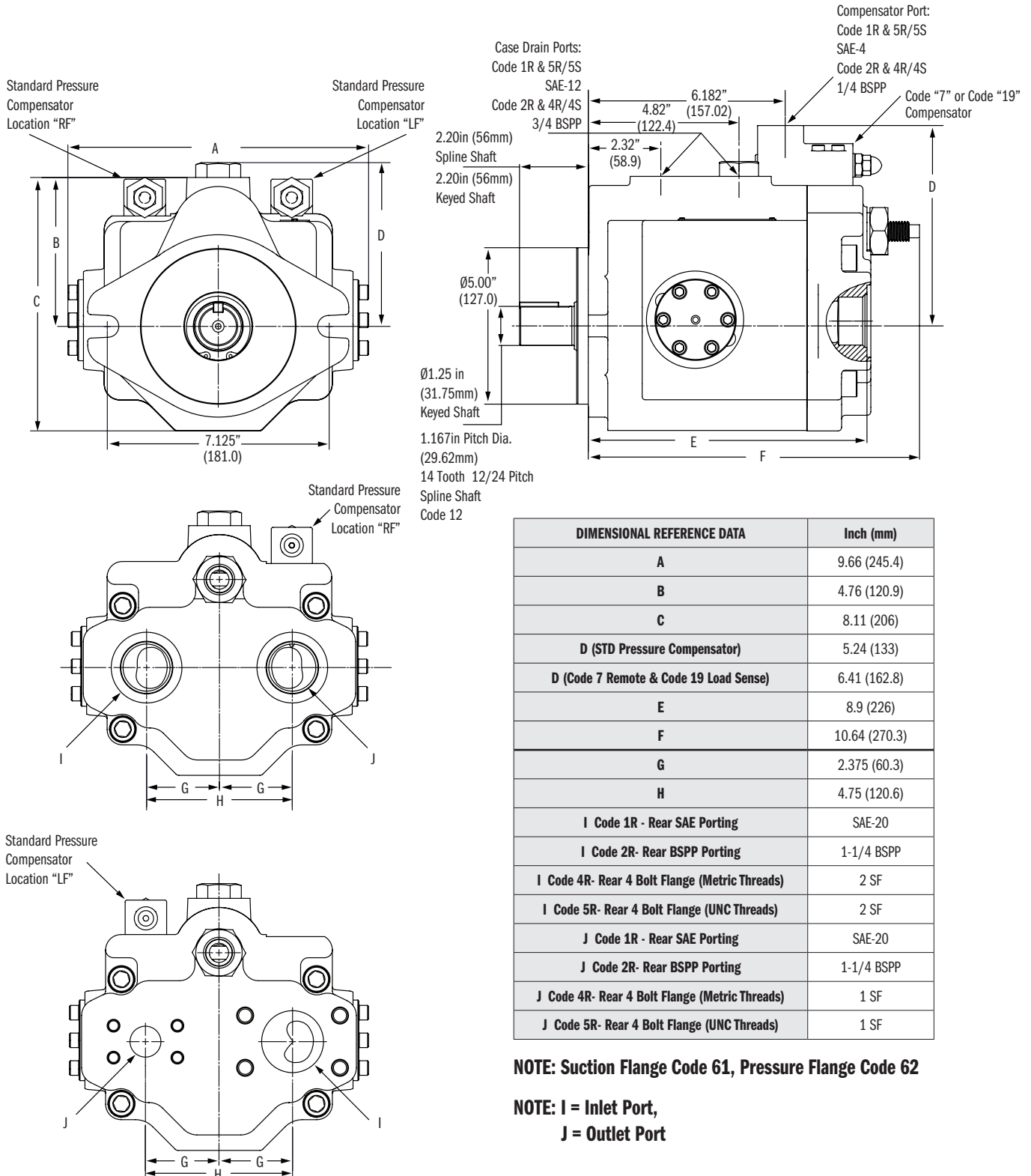

► **HPVR-29 INSTALLATION DATA:**

FEATURES: SIDE PORT DIMENSION DATA - MAX RATED 3500 PSI CONTINUOUS

Dimensions:
inches (± .125")
millimeters (± 1 mm)

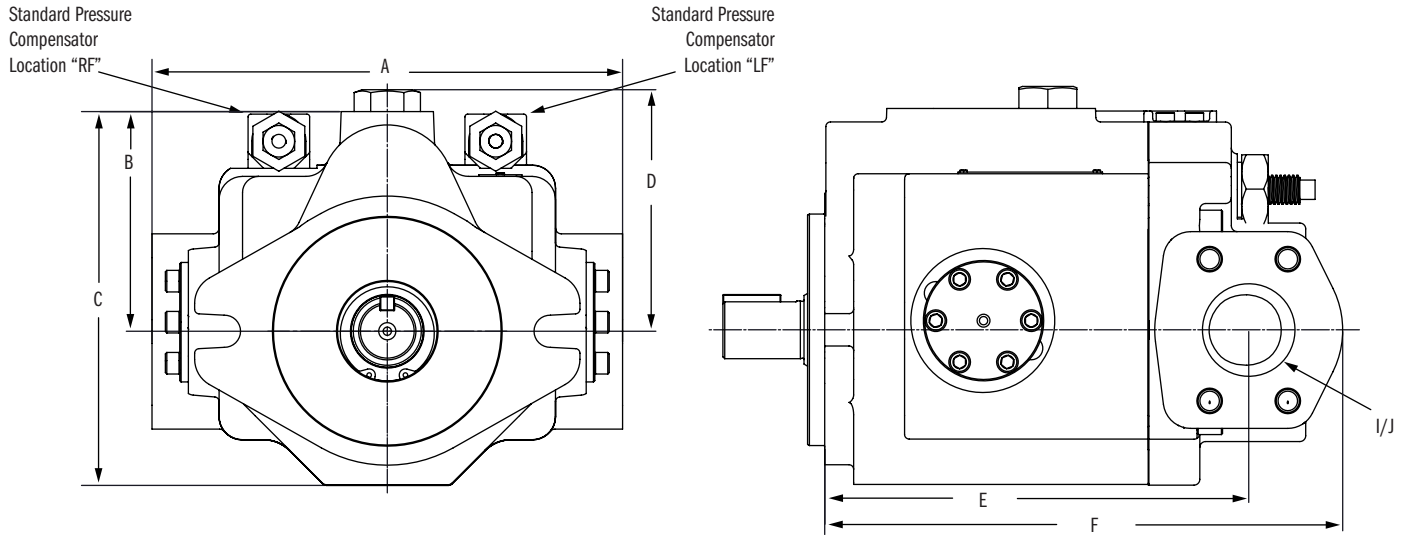

DIMENSIONAL REFERENCE DATA	Inch (mm)
A	10.24 (260.1)
B	4.76 (120.9)
C	8.11 (206)
D (STD Pressure Compensator)	5.24 (133)
D (Code 7 Remote & Code 19 Load Sense)	6.41 (162.8)
D (Code 26 Torque Limit)	9.52
E	9.16 (232.7)
F	11.12 (282.5)
I Code 4S- Side 4 Bolt Flange (Metric Threads)	2 SF
I Code 5S- Side 4 Bolt Flange (UNC Threads)	2 SF
J Code 4S- Side 4 Bolt Flange (Metric Threads)	1 SF
J Code 5S- Side 4 Bolt Flange (UNC Threads)	1 SF

Note: Suction Flange are code 61 and Pressure Flange are code 62

**NOTE: I = Inlet Port,
J = Outlet Port**

▶ HPVR-29 INSTALLATION DATA:
FEATURES: SIDE PORT DIMENSION DATA - MAX RATED 3500 PSI CONTINUOUS

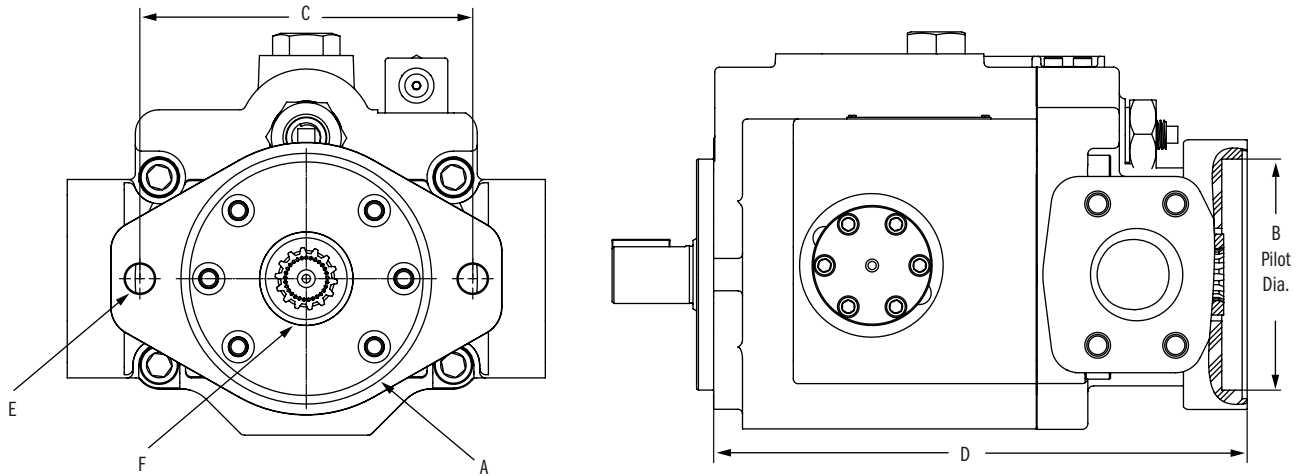
 Dimensions:
 inches (± .125")
 millimeters (± 1 mm)

CODE	Mounting Pad	Dimensions (Inches (mm))				Thread	30 Involute Internal Spline	Maximum H.P. Rating* (at 1750 RPM)	Maximum Torque Rating* (in-lbs)
	A	B	C	D	E	F			
21	SAE "A"	3.25 (82.6)	4.19 (106.4)	11.27 (286.26)	3/8-16 UNC	9 Tooth 16/32 Pitch 0.5625 Dia.	8.5	306	
22	SAE "B"	4.00 (101.6)	5.75 (146.1)	11.43 (290.3)	1/2-13 UNC	13 Tooth 16/32 Pitch 0.8125 Dia.	28.1	1012	
23	SAE "C"	5.00 (127.0)	7.13 (181.1)	11.55 (293.4)	5/8-11 UNC	14 Tooth 12/24 Pitch 1.1667 Dia.	43.8	1577	
31	SAE "A"	3.25 (82.6)	4.19 (106.4)	11.27 (286.26)	3/8-16 UNC	13 Tooth 16/32 Pitch 0.8125 Dia.	28.1	1012	
21D	SAE "A"	3.25 (82.6)	4.19 (106.4)	11.27 (286.26)	M10	9 Tooth 16/32 Pitch 0.5625 Dia.	8.5	306	
22D	SAE "B"	4.00 (101.6)	5.75 (146.1)	11.43 (290.3)	M12	13 Tooth 16/32 Pitch 0.8125 Dia.	28.1	1012	
23D	SAE "C"	5.00 (127.0)	7.13 (181.1)	11.55 (293.4)	M16	14 Tooth 12/24 Pitch 1.1667 Dia.	43.8	1577	
31D	SAE "A"	3.25 (82.6)	4.19 (106.4)	11.27 (286.26)	M10	13 Tooth 16/32 Pitch 0.8125 Dia.	28.1	1012	

* This is the maximum horsepower or torque that can be transmitted through the shaft coupling to the rear pump

SEAL KIT

	HPVR-6	HPVR-10	HPVR-15	HPVR-20	HPVR-29
BUNA SEAL KIT	1025398	1025399	1025400	1025401	1025402
VITON SEAL KIT	1025403	1025404	1025405	1025406	1025407

**FIELD CONVERSION
COMPENSATORS**

	BUNA	VITON
STD PRESSURE COMP	261097	261098
REMOTE COMP (7)	261099	261100
LEAD SENSING (19)	261103	261104