



# Original instruction

## CONTENTS

# OILCON 10 series

## Oil Cooling Unit (Circulation type)



- The fluorinated greenhouse gases are contained in hermetically sealed.
- To prevent global warming, when relocating, repairing, or disposing of this product, collect fluorocarbons in accordance with the laws of your country.

### Models

Menu Series	Standard model	Built-in breaker model (-B)	CE/UKCA model (-C)	Modbus communication (-J)	Built-in heater model (-H)	Built-in tank model (-T)	Different- voltage
AKZ14A	<input type="checkbox"/>	<input type="checkbox"/>	<input type="checkbox"/>	<input type="checkbox"/>	<input type="checkbox"/>	<input type="checkbox"/>	<input type="checkbox"/>
AKZ32A	<input type="checkbox"/>	<input type="checkbox"/>	<input type="checkbox"/>	<input type="checkbox"/>	<input type="checkbox"/>	<input type="checkbox"/>	<input type="checkbox"/>
AKZ43A	<input type="checkbox"/>	<input type="checkbox"/>	<input type="checkbox"/>	<input type="checkbox"/>	<input type="checkbox"/>	<input type="checkbox"/>	<input type="checkbox"/>
AKZ56A	<input type="checkbox"/>	<input type="checkbox"/>	<input type="checkbox"/>	<input type="checkbox"/>	<input type="checkbox"/>	<input type="checkbox"/>	<input type="checkbox"/>
AKZ90A	<input type="checkbox"/>	<input type="checkbox"/>	<input type="checkbox"/>	<input type="checkbox"/>	<input type="checkbox"/>	<input type="checkbox"/>	<input type="checkbox"/>

Thank you for purchasing our OILCON.  
This instruction manual includes precautions for using the OILCON.

To ensure proper use of this product, be sure to read through this instruction manual before using it.

After reading this manual, keep it handy for your future reference.

### Proper use results in power saving

If the air filter is clogged, the cooling performance deteriorates, causing excess power consumption.

Clean the air filter periodically to reduce power consumption.

### Read First

Safety Precautions.....	1
Main Applications .....	5

### Installation

Method of Transportation / Conveyance / Storage.....	6
Precautions for Installation.....	7
Reference for Pipe Selection .....	8
Electric Wiring .....	10

### Handling

Check Before Operation.....	16
Part Names and Functions .....	17
Outline of control panel.....	18
Checking Initial Conditions.....	19
About Operations.....	20

Hold a Constant Oil Temperature.....	22
Tune the oil temperature to room temperature (or machine temperature) .....	23
Cool the Oil at Constant Capacity (%) .....	24

Monitor Items.....	25
Timer Operation .....	26
About Special Functions .....	27
Setting Special Function .....	29
For Temperature Control Improvement.....	32

### Optional Parts (Sold Separately)

Machine temperature tuning control.....	35
Returned oil temperature control .....	36
Communication with main machine.....	37

### Maintenance

Maintenance/Inspection .....	38
• Daily maintenance/inspection	
• Periodic maintenance/inspection	
• To leave the unit unused for a long period	

Troubleshooting .....	39
• When the unit operation seems abnormal although no alarm is activated	
• When an alarm is activated	
• When a warning is activated	

### Product Specifications

Specifications Table .....	44
Electric wiring diagram.....	46

Installation  
Procedure

Before  
Operation

Operating  
Procedure

Useful  
Functions

Optional  
Functions

Maintenance

Troubleshooting

Product  
Specifications



# Safety Precautions

Before using this product, read the following instructions carefully to ensure proper use.

- The instructions described below are intended to prevent injury or damage to you and other people. Possible conditions that may result from improper handling are classified as follows:

 <b>DANGER</b>	 <b>WARNING</b>	 <b>CAUTION</b>
This category indicates urgently hazardous conditions that may result in death or serious injury.	This category indicates potentially hazardous conditions that may result in death or serious injury.	This category indicates potentially hazardous conditions that may result in injury or property damage only.

- All these instructions include important information on safety. Be sure to observe the instructions.
- After reading this manual, be sure to keep it in place so that users can read it whenever required.
- If this product is transferred to another person, be sure to attach this manual to the product.
- To use this product safely, be sure to observe the following instructions, and safety laws and regulations for the relevant standards listed below.

1. Industrial Safety and Health Law
2. Fire Service Law
3. JIS B8361 General Rules for Hydraulic Systems

## Precautions for installation

### **DANGER**



**Mandatory**

#### **Only qualified people can handle the unit.**

Transportation, installation, piping, electric wiring, operation, maintenance and inspection of the unit must be conducted by qualified people.  
Check the power supply (voltage, frequency and current).

#### **Connect the power cable according to the procedure described in this instruction manual.**

Connect the power cable according to the procedure described in "Electric Wiring" on page  10.

#### **Check the weight, and hang the unit by the specified points.**

Check the weight of the unit with the nameplate to make sure that it does not exceed the rated load capacity of the carrier. Hang the unit by the points specified in the outline drawing. Also, do not install and hang things other than the OILCON. Failure to observe this instruction may result in fall or overturn of the unit, causing injury or property damage.



**Ground cable connection**

#### **Ground the unit securely.**

If the unit is not grounded, you may get an electric shock.

## **WARNING**



**Mandatory**

### **Conduct electric wiring according to the ratings.**

Conduct electric wiring in accordance with respective national and regional standards. Improper wiring may result in burnout or fire.

### **Fasten the unit during operation.**

Check the fastening points with the outline drawing, and fasten the unit securely with bolts or foundation bolts. Failure to observe this instruction may result in fall or overturn of the unit, if this unit is installed at an elevated position.

### **Check the power cable, and have it replaced by a qualified person if it is damaged**

If the power cable is damaged, there is a danger of earth leakage. Have it replaced by a certified electrician such as a manufacturer or service provider.



**Forbidden**

### **Keep away from the unit when it is being carried with slings.**

Never get close to the unit when it is being carried with slings. Also, do not install and hang things other than the OILCON. Failure to observe this instruction may result in fall or overturn of the unit, causing injury or property damage.

### **Do not climb on the OILCON (when it is packaged)**

Do not climb on the OILCON when it is transported or installed. You may become trapped under the oil controller due to the package falling.

## **CAUTION**



**Mandatory**

### **Prepare an earth leakage circuit breaker at user's site.**

The OILCON is not equipped with an earth leakage circuit breaker. An earth leakage circuit breaker (3-pole) exclusively for the OILCON should be provided by user. (\*)

To use an earth leakage breaker, select an inverter-compatible type.

(Recommended: Rated sensitivity current 15 mA or 20 mA)

\* The earth leakage circuit breaker must conform to IEC 60947-2, and the distance between the contacts must be more than 3 mm.

### **Check the oil piping.**

Before or immediately after connection of the OILCON, make sure that the oil piping of the main machine is not blocked (fully closed). If the unit is operated with the oil piping blocked (fully closed), the oil hose may break due to an oil temperature rise, causing oil to flow out of the OILCON. When the oil temperature abnormally rises, the FH alarm is activated. In this case, stop operation of the main machine as soon as possible.

### **Provide a flow switch for the main machine.**

If the pump motor operation system has a fault, oil cannot be supplied to the main machine. Normally in this case, the OILCON detects the fault and outputs an alarm signal. However, it may not be detected depending on the fault mode. If the main machine must be protected even in such a case, provide a flow switch for the oil flow path of the main machine to watch the oil flow.

### **Check altitude**

Do not use at an altitude of 2,000m or more.

Insulation resistance may decrease, resulting in electric shock.

## Precautions for use



**Mandatory**

### **Before handling this unit, turn OFF the power supply.**

Before handling this unit, be sure to turn OFF the power supply.

Handling this unit while power is being supplied may result in electric shock.

To prevent erroneous powering while handling this unit, use this unit with the power box locked.

### **Do not use the unit beyond specified operating conditions.**

Do not use this unit in any condition other than those specified in the catalog or delivery specifications. Failure to observe this instruction may result in a serious accident, such as damage to the main machine, injury, fire and electric shock.



**Forbidden**

### **Do not handle the unit for 5 minutes after power supply is turned OFF.**

During this period, electric discharge from the internal high-voltage parts (capacitors) has not been completed. Failure to observe this instruction may result in electric shock.

### **Do not operate the unit with the covers opened.**

Do not operate the OILCON with the unit casing or terminal covers of the motor or other electric parts removed. Failure to observe this instruction may result in electric shock.

### **Keep your hand or body away from the unit during operation.**

During operation, the external casing may become extremely hot. Be careful that your hand or body does not directly touch it. Otherwise, you may get a burn.

### **Observe the supervision and instructions of the safety manager**

The appliance is not intended for use by persons (including children) with reduced physical, sensory or mental capabilities, or lack of experience and knowledge, unless they have been given supervision or instruction concerning use of the appliance by a person responsible for their safety.

Children should be supervised to ensure that they do not play with the appliance.

### **Do not use the unit in explosive atmosphere.**

Do not install this unit in a place where evolution, inflow, retention or leak of inflammable gas may be expected, or where airborne carbon fiber is present. Failure to observe this instruction causes fire.



**Do not disassemble**

### **Do not disassemble or repair the unit.**

Do not modify this unit.

Any person other than DAIKIN authorized service personnel must not disassemble or repair this unit. Failure to observe this instruction causes fire, electric shock or injury.

If this unit is disassembled, repaired or modified by an unauthorized person, it shall not be beyond the scope of warranty.



**Forbidden**

### **Do not splash water.**

Do not immerse this unit in water, or splash water on the unit. Failure to observe this instruction may result in short-circuit or electric shock.

Do not touch electric components with wet hands. Failure to observe this instruction may result in electric shock.

## **WARNING**



**Mandatory**

### **If refrigerant leaks, provide thorough ventilation.**

If a large quantity of refrigerant is filled in the site, people in the site may be anesthetized or suffocated. With the CE/UKCA model, SDS (Safety Data Sheet) for the refrigerant is attached to the product. Take an action according to the SDS.

### **Use a commercial power supply.**

Be sure to use a commercial power supply. Using an inverter power supply may result in burnout.

### **If an abnormal condition occurs, stop operation immediately.**

If an abnormal condition occurs, stop operation of the unit, and leave it unused until the cause of the trouble is securely removed. Failure to observe this instruction may result in damage to the unit, electric shock, fire or injury.

### **Turn OFF the earth leakage circuit breaker.**

After stopping operation, be sure to turn OFF the earth leakage circuit breaker.



**Forbidden**

### **Do not step on the unit.**

Do not sit or step on this unit. Failure to observe this instruction may result in fall or overturn of the unit, causing injury.

If the system is broken, the live parts may be exposed. Failure to observe this instruction may result in electric shock.



**Caution**

### **Do not put a finger or foreign object in an aperture of the unit.**

To ensure safety, a cover or casing is mounted to rotary parts. Do not put a finger or foreign object in an aperture of the cover or casing. Failure to observe this instruction may result in injury.

## **CAUTION**



**Mandatory**

### **During transportation, fasten the unit securely.**

Fasten this unit securely so that it will not be moved by vibration or external force during transportation.

If strong vibration or external force is applied to the unit, the internal equipment may be damaged.

### **Ensure safety of the main machine before trial run.**

Before executing a trial run, make sure that the main machine is set in safe conditions (the main machine will not run, or no accident occurs even if the main machine runs.) Failure to observe this instruction may result in injury or damage to the machine.

### **Check the unit before operation.**

Before start of operation, make sure that the oil piping and electric wiring are properly conducted, and connecting parts are securely tightened.



**Forbidden**

### **Do not use the unit in special atmosphere.**

Do not use this unit in a special atmosphere including dust, oil mist or corrosive gas (H<sub>2</sub>S, SO<sub>2</sub>, NO<sub>2</sub>, Cl<sub>2</sub>, etc.), or at a high temperature or high humidity.

### Electrical Hazard

You may be seriously injured or killed because of an electric shock or fire. Do not open the cover of electric component box during the operation.

Maintenance and inspection should be carried out by qualified personnel after the power supply is turned OFF.

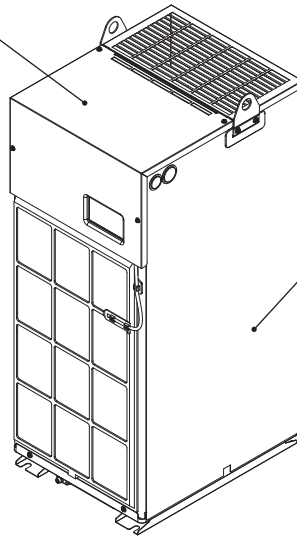

### Heat

Do not touch the external casing of the main unit or internal equipment during the operation (otherwise, you may burn yourself).

## Main Applications

### ■ Example of major applications

Machine tools: Machining center, NC lathe, grinding machine, NC specialized machine, NC electric discharge machine, etc.

Industrial machine: Molding machine, press, etc.

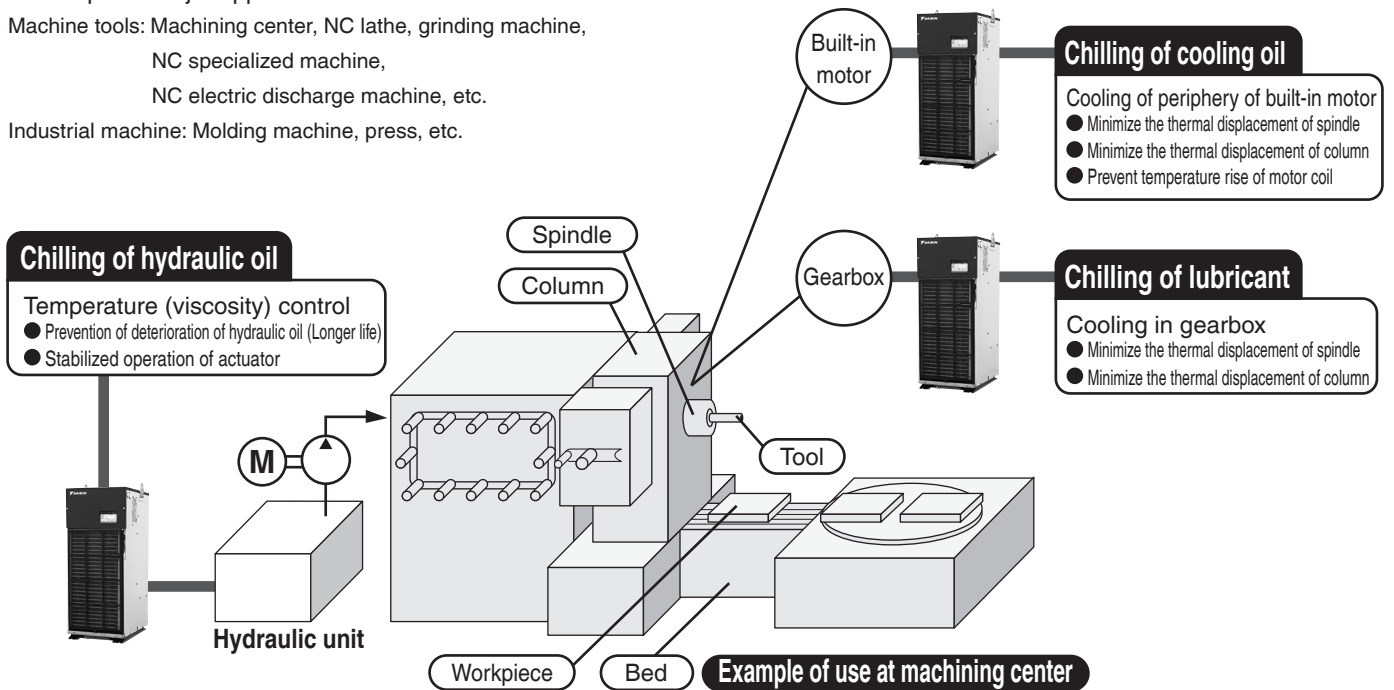

# Method of Transportation / Conveyance / Storage

## Precautions on transportation / conveyance / storage

- During transportation or conveyance, wear gloves and a helmet.
- Do not transport or convey the product by any method other than that specified below.
- For a product with a tank (-T), do not transport or convey the unit by hanging with the eye plate, because the unit may fall or oil may be spilled if the tank is filled with oil.
- Do not transport or convey the unit after installing the tank or other equipment, which is prepared by the customer, by hanging with the eye plate. The unit may fall.
- For the different-voltage model (-048), carry out the transportation or conveyance using the hanger of transformer box. If you hang it using the eye plate, it may fall.
- Set the ambient storage temperature to 0 to 55°C (annual average 25°C) and set the ambient humidity to 95% (RH) or less (annual average is less than 75%).
- Do not tilt the OILCON more than 30°. If the unit is tilted more than 30°, the compressor may have a fault.
- If the liquid is sealed inside the product, the pressure will increase as the temperature rises, which may break the hose or leak. When transporting or storing the product, be sure to drain the liquid inside the product.

## Method of Transportation / Conveyance

Carry out the transportation or conveyance according to the following method.

- Carry out the transportation or conveyance by fixing the hanging tool to the right and left eye plates.
- Stay away from the product during transportation or conveyance using the hanging tool.

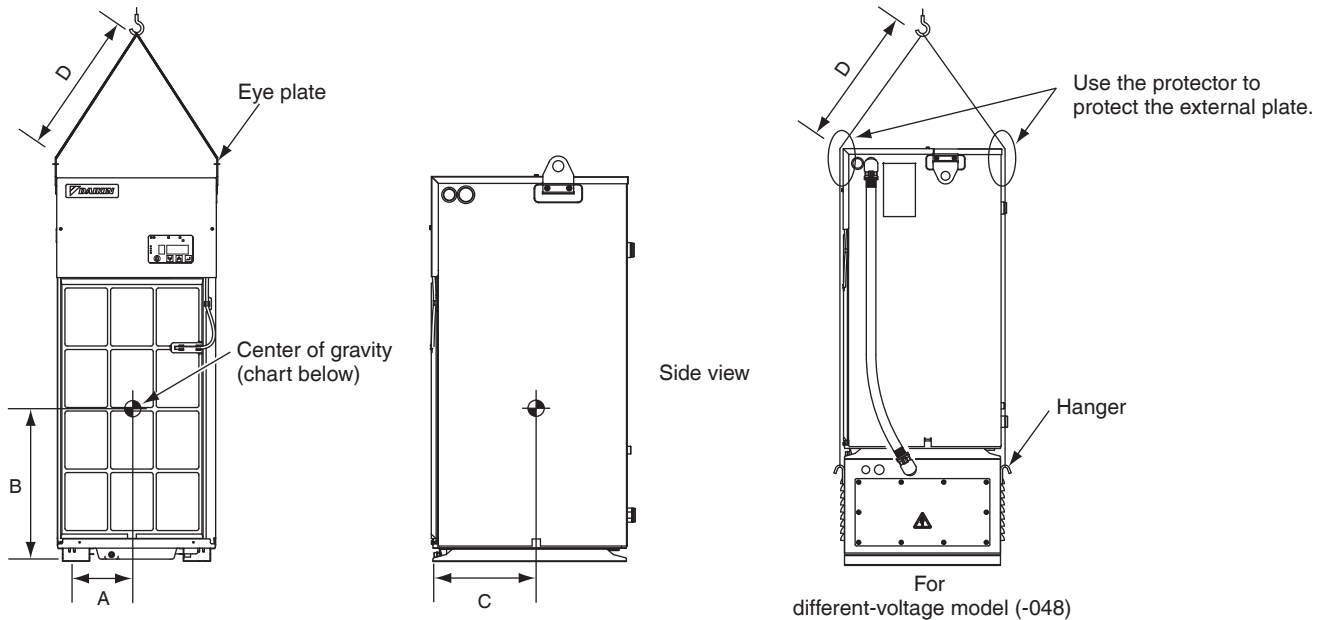

### Center of gravity position (Reference)

Unit: mm

		A	B	C	D
AKZ14A	-B, -C, -J	160	295	230	400 or more
	-T	160	380	220	
	-H	160	455	225	
	-048	145	405	220	
AKZ32A	-B, -C, -J	155	340	235	
	-T	155	440	220	
	-H	155	490	225	
	-048	145	440	225	
AKZ43A	-B, -C, -J	155	375	235	
	-T	155	470	220	
	-H	155	515	225	
	-048	145	470	225	
AKZ56A	-B, -C, -J	190	420	275	500 or more
	-T	190	555	270	
	-H	190	560	270	
	-048	200	280	445	
AKZ90A	-B, -C, -J	230	450	330	600 or more
	-T	235	575	335	
	-H	235	580	325	
	-048	250	335	455	

6 \* The position of the center of gravity is defined with no liquid inside the cooler.



# Precautions for Installation

## Installation place

■ For an installation place, observe the following.

1. Horizontal and rugged floor face (vertical interval 5 mm or less)  
When you install the product, fix it with a bolt (M10×20 hexagonal bolt is recommended).
2. A place where the unit is not exposed to direct sunlight or heat
3. A place with proper ventilation and little humidity
4. A place where exhaust air does not circulate (exhaust air will not be taken into the unit)
5. A place that allows easy access to piping and wiring
6. A place with little contaminant, waste, dust particles or oil mist  
(Ensure that no foreign matter enters the electric component box.)
7. A place free from explosive atmosphere (evolution, inflow, retention or leak of inflammable gas)
8. Do not install the unit outdoors.
9. Install the unit within 1 m of the tank level. (Otherwise, it will affect the sucking capability of the pump.)
10. Keep any electrical noise generating devices away from the unit. If it is difficult to do so, implement appropriate measures on the noise generating devices.
11. Leave safe, sufficient space around the unit to ensure proper, trouble-free operations of the control panel.
12. Do not install at an altitude of 2,000m or more.
13. Do not place an object that may block air flow within 500 mm from the air intake/exhaust port.

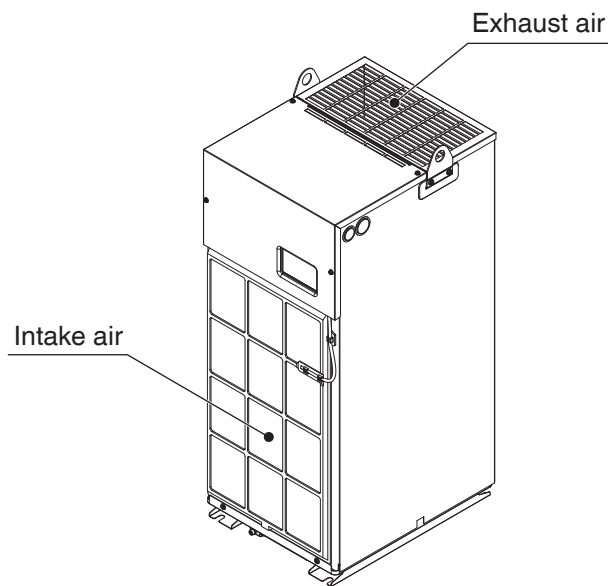

## Oil tank

- To receive oil from the main machine oil piping system, provide an oil tank that can accept an increase/decrease in oil quantity.
- Consider the tank structure so that inside of the tank can be easily cleaned. (For example, the tank has a cleaning hole or the tank top plate is detachable.)
- Before the start of operation, make sure that the tank is filled with oil to an appropriate level.

# Reference for Pipe Selection

## Piping

- Locations of the oil inlet, oil outlet and oil drain are shown below.  
Oil may remain inside the OILCON, so prepare something to catch the oil, such as an oil tray.

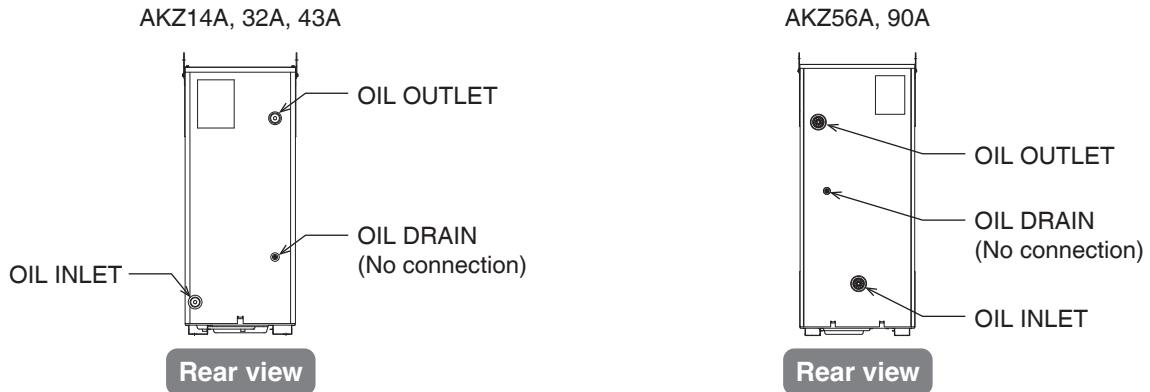

- Make sure that the pressure loss at the oil inlet/outlet is within the following range:
  - Suction pressure (at oil inlet) ..... -30.7 to 0 kPa
  - Discharge pressure (at oil outlet) ..... 0.5 MPa or less
 However, if the atmospheric pressure drops, use thorough caution about suction pressure.  
In case atmospheric pressure drops, be careful of the decrease of inlet suction pressure.  
(Reference)Reduction of the pressure at altitude:-1kPa/100m
- Use piping that can withstand a pressure of more than 1MPa and with oil resistance characteristics, and avoid using a valve in the middle of the piping as much as possible.  
If a valve is used, it causes a large pressure loss even when it is fully opened.
- If the oil viscosity is high, or if there is a large pressure loss in external piping (other than the piping for the OILCON), use a pipe with a larger diameter to reduce the pressure loss. (To change the pipe size, refer to “**Pipe size/maximum pipe length chart**” on page 9.)  
If the operating condition exceeds the specified range, it causes noise or fault of the unit. Use thorough caution about the operating condition. Keep the oil viscosity at 1.4 to 200 mm<sup>2</sup>/s.
- To prevent air entry or oil leak, wrap the pipe joints with sealing tape, etc.
- Make sure that the oil piping of the main machine is not blocked (fully closed).

## Suction strainer (Line filter)

Attach a strainer (mesh size: 100 to 150) with a small pressure loss to the oil piping system.

- If the evaporator (cooler) in the OILCON is clogged with dust, it causes not only cooling capacity deterioration, but also a fault of the compressor or pump motor.
- During adjustment at trial run, the strainer gathers much dust from the oil piping system. Clean or replace the strainer before starting actual operation. Check the strainer periodically.
- The oil pollution level must not exceed NAS class 10.

## Connection pipe diameter (Standard model)

Model	AKZ14A • 32A • 43A	AKZ56A • 90A
Oil Inlet	Rc3/4	Rc1 1/4
Oil Outlet	Rc3/4	Rc1 1/4
Oil Drain	Rc1/4	

\* For menu models, refer to “Specifications Table” on page 44-45.

# Pipe size / maximum pipe length chart

Suction pipe (Hose inner diameter)

Unit: m

Model		Size (mm)	φ19	φ25.4	φ31.8	φ38.1
AKZ14A	50 Hz		2.1	6.3	(15)* <sup>1</sup>	—
	60 Hz		1.7	5.1	(12)* <sup>1</sup>	—
AKZ32A AKZ43A	50 Hz		—	2.8	6.7	—
	60 Hz		—	2.3	5.5	—
AKZ56A AKZ90A	50 Hz		—	—	5	10
	60 Hz		—	—	4	8

Discharge pipe

Unit: m

Model		Size (mm)	φ12.7	φ19	φ25.4	φ31.8
AKZ14A	50 Hz		4.2	21	*2	—
	60 Hz		3.4	17	*2	—
AKZ32A AKZ43A	50 Hz		1.8	9	28	—
	60 Hz		1.4	7	23	—
AKZ56A AKZ90A	50 Hz		—	—	20	48
	60 Hz		—	—	16	40

Condition: ISO VG32, Viscosity: 200 mm<sup>2</sup>/s

\*1: The above pipe size may not be applied to the unit, depending on the pipe specifications. For details, contact Nearby Service Network.

\*2: Refer to the pipe resistance calculation formula.

## Pipe resistance calculation method

To determine the oil pipe size, calculate it based on the following formula:

$$\Delta P = 0.595 \times V \times Q \times L / D^4$$

(For general hydraulic oil/lubrication oil)

ΔP: Pipe resistance (MPa)

V: Kinematic viscosity coefficient (mm<sup>2</sup>/s)

.....See "Viscosity vs. Temperature" chart.

Q: Flow rate (L/min)

L: Pipe length (m)

D: Pipe inner diameter (mm)

\* For flow rate (Q), refer to "Oil pump discharge rate" in "Specifications Table" on page 44-45.

Example of viscosity (Kinematic viscosity coefficient)

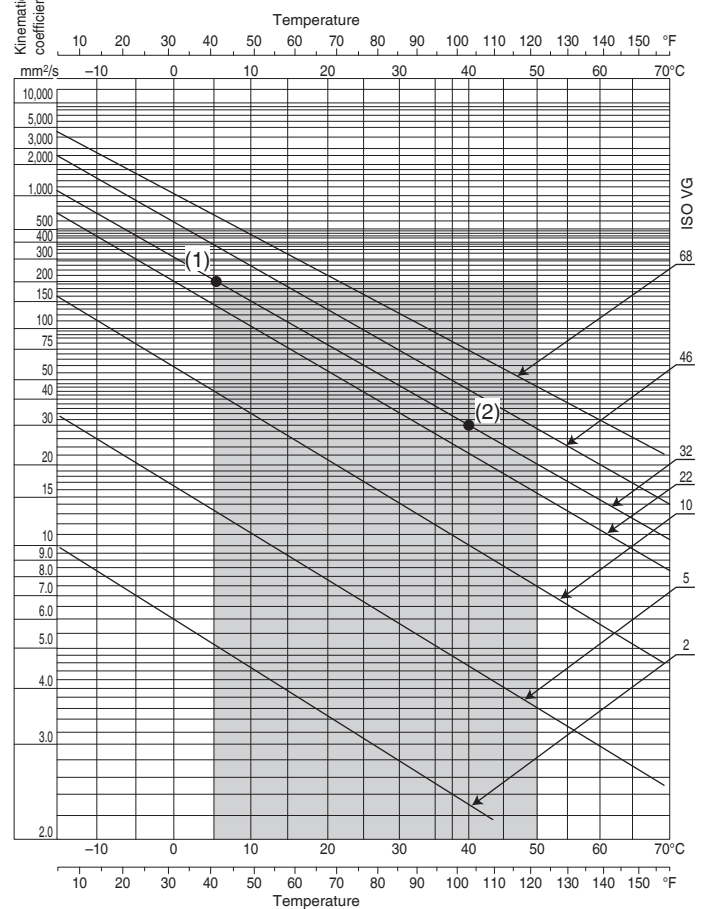

(1) In winter: 195 mm<sup>2</sup>/s (ISO VG32, Oil temperature: 5°C)

(2) In summer: 29 mm<sup>2</sup>/s (ISO VG32, Oil temperature: 40°C)



# Electric Wiring



## Precautions when wiring

 <b>WARNING</b>	
	Conduct electric wiring in accordance with respective national and regional standards. Be sure to use a commercial power supply. Using an inverter power supply may result in burnout.
	Do not change the wiring in the OILCON. Do not touch the protection devices.

(Note)

For electric wiring, refer to the electric wiring diagram on the nameplate attached to the rear of the electrical equipment box cover.





## Mounting an earth leakage circuit breaker

 <b>CAUTION</b>	
	<p>The OILCON is not equipped with an earth leakage circuit breaker. Be sure to mount a 3-pole earth leakage circuit breaker (*) exclusively for the OILCON to the main machine, or if you are using a wiring circuit breaker (breaker), take separate measures against earth leakage. For the breaker capacity, refer to the specifications of each model (see page 44-45).</p> <p>To use an earth leakage breaker, select an inverter-compatible type.</p> <p>If the earth leakage breaker is not inverter-compatible, it may malfunction due to high-frequency noise of the inverter. (Recommended: Rated sensitivity current 15 mA or 20 mA)</p> <p>* The earth leakage circuit breaker must conform to IEC 60947-2, and the distance between the contacts must be more than 3 mm.</p>

## Starting/stopping the OILCON

To turn ON the power supply for the OILCON, the following three methods are available:

- 1) Starting/stopping the unit with the Earth-Leakage Circuit Breaker on the main machine
- 2) Starting/stopping the unit with the remote control contact (see page 14)
- 3) Starting/stopping the OILCON with the control panel

If you keep pressing the  and  keys for at least 5 seconds in the “operation lock” mode, the OILCON starts operation according to preset conditions. If you keep pressing the  and  keys for at least 5 seconds during operation, “Loc” blinks on the data display, and the OILCON will be stopped (locked).

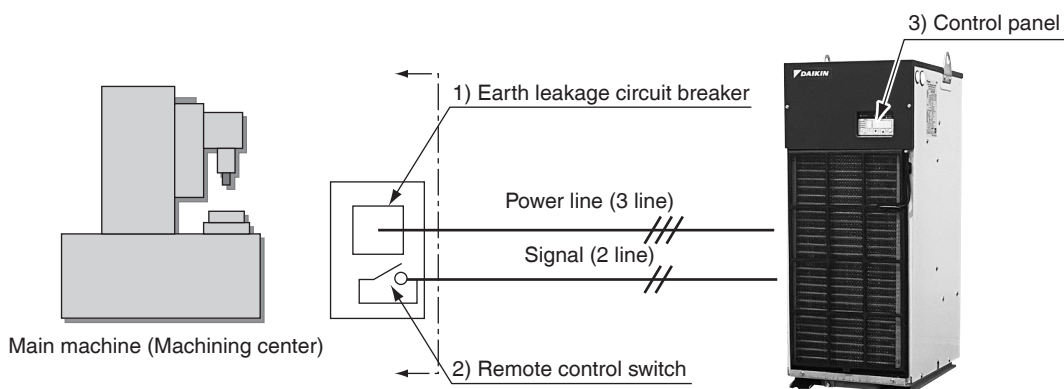

# Wiring procedure

The cables below must be acquired separately.

Model/Series name	UL cable	IEC/CENELEC cable
AKZ14A/32A/43A/56A series	UL1015 AWG#14 (equivalent to 2.0 mm <sup>2</sup> )	2.5 mm <sup>2</sup> (60245 IEC53/H05RR-F)
AKZ90A series	UL1015 AWG#12 (equivalent to 3.5 mm <sup>2</sup> )	4.0 mm <sup>2</sup> (60245 IEC53/H05RR-F)

- For each wiring, use M4 or M5 coated round crimp-style terminal. (For the crimp tool, use the specified tool. Carry out the processing of the crimp-style terminal to prevent short-circuits between phases.)
- The tightening torque of the screw to the terminal block should be 0.98 to 1.47N·m.
- Carry out the processing of the wiring carefully not to damage the electric wire coating.
- Fix the electric wire and the signal wire to the anchor mount with tie wrap. (See page [12](#))

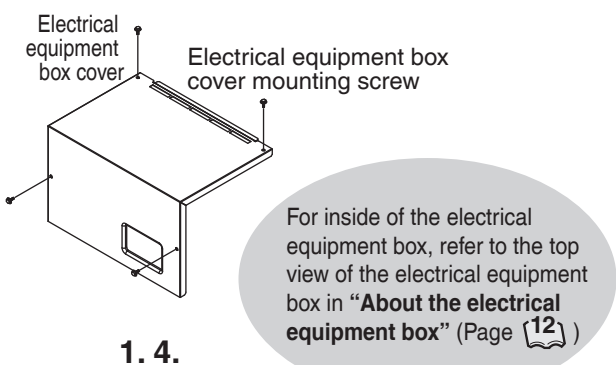

1. 4.

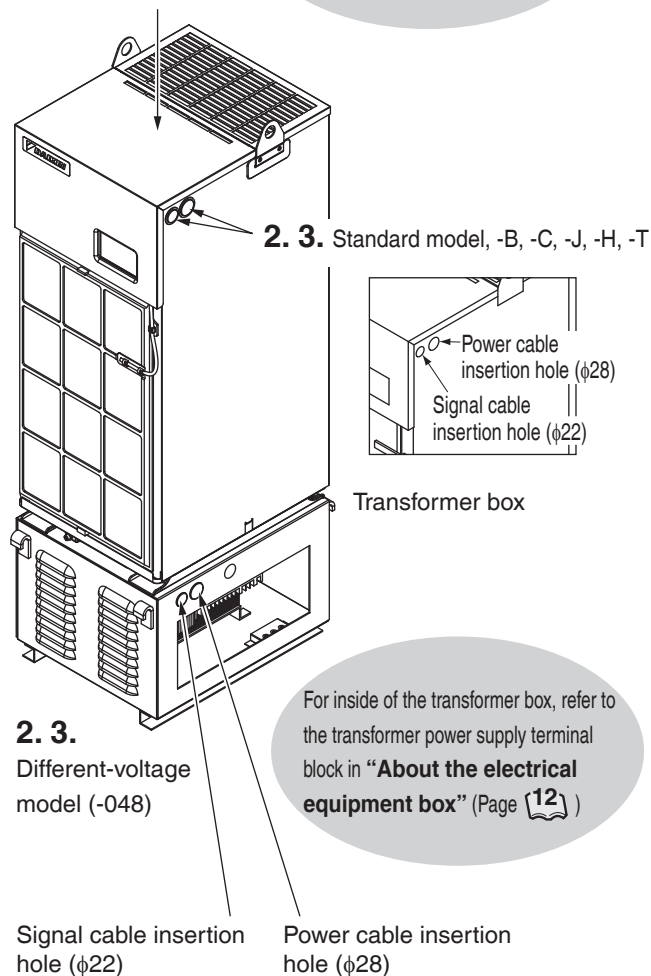

**1. Remove the electrical equipment box cover mounting screws, and remove the electrical equipment box cover.**

**2. 1) Insert the power cable into the power cable insertion hole (φ28) in the side plate of the unit. When using the different-voltage model (-048), insert the power cable into the transformer box.**

**2) Insert the remote control signal cable and external output signal cable into the signal cable insertion hole (φ22) in the side plate of the unit.**

\* Use conduits with IP54 or higher for wiring intake to allow the electric component box to have a protective structure equivalent to IP54. If the electric component box is affected by electrical noise, use conduits or shielded cables. Allow a proper distance from the potential noise source.

**3. 1) Connect the ground cable to the (ground) terminal.**

**Use green/yellow ground cable.**

**2) Connect the power cable to the power supply terminal block.**

**Connect the power cable to the breaker if OILCON is supplied with breaker.**

■ When you remove the power cables, follow the instructions above in reverse. (Default setting is breaker OFF.)

■ For **remote control input connecting** procedure, refer to page [14](#).

■ For **external output contact connecting** procedure, refer to page [13](#).

**4. Re-mount the electrical equipment box cover, and fasten it with the screws.**

■ Secure the electrical equipment box cover mounting screws with 1N·m to maintain the protection structure of the electrical equipment box.

# About the electrical equipment box (Typical: AKZ32A)

Model	Terminal screw size	Tightening torque (N·m)
Terminal block for standard model (Including -C, -J, -H and -T)	M4, M5	0.98–1.47
Breaker terminals (-B)	M5	2–3
Transformer terminals (-048)	M4	1.2–2.0

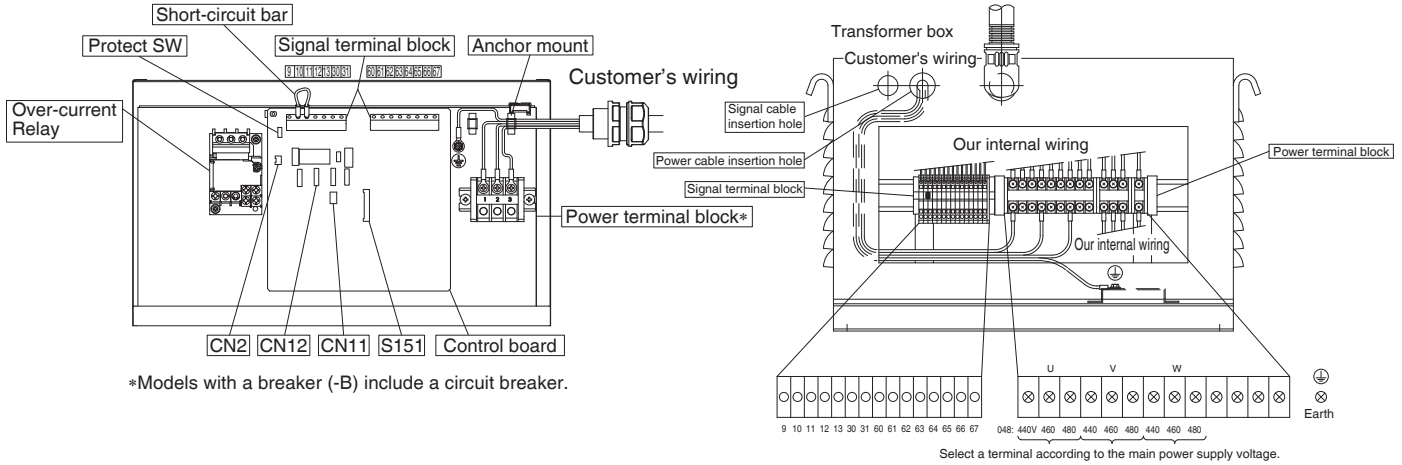

**For different-voltage model (-048)\***  
 (\*Wiring connection example when the voltage is 440V)

Protect switch (erroneous operation prevention)	Factory Default Setting: OFF (ON in some non-standard machines) Pay attention when you attempt to change any of the operation setting, parameter setting or timer setting.
Connector CN2 (Option OP2 terminal)	Refer to “Alarm Settings for Optional Protection Devices” (page 14).
Connector CN11	Refer to “Returned oil temperature control” (page 36).
Connector CN12	Refer to “Communication with main machine” (page 37).
Connector S151	Refer to “Communication with main machine” (page 37).

## Connection of signal terminal block

This is connected when the operation status of the OILCON is to be input into the main machine. If the output contact is to be used, refer to “Alarm/Warning Output Logic” (page 15).

### ■ The cables below must be acquired separately

Bar-type Terminal	Cable size	
	IEC cable	UL cable
*	0.3 mm <sup>2</sup> -1.5 mm <sup>2</sup>	AWG22-16

\* Recommended Model (Manufacturer): TGN TC-1.25-9T (Nichifu)

- If using a twisted cable, the use of a bar-type crimp terminal is recommended.
- When a 2-core IEC cable is used, the cable size should be 0.5 to 1.5 mm<sup>2</sup>.
- When you use a stripped cable, strip the sheath 9 to 10 mm from the end of the cable.

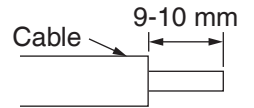

### ■ Cable connection and removal

- If using a bar-type terminal, you can connect the cable simply by inserting it.
- If using a twisted cable that has been stripped, connect the cable while pushing the terminal push button down vertically in relation to itself as shown in the figure on the right.
- When removing the cable, pull the cable out while pushing the terminal push button down vertically in relation to itself as shown in the figure on the right.

\* If you push the terminal push button down diagonally, the terminal may be damaged.

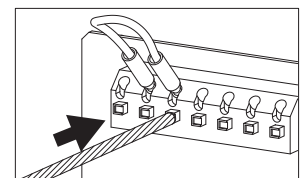

Recommended tool: 210-719 (WAGO)

# Connection of external output contact

To output the OILCON operation status signal to the main machine, connect the required signal cable to the signal terminal block. (For the connecting method, refer to “Connection of signal terminal block” on page 12.) For details of alarms, refer to “Alarm list” (page 44). For details of warnings, refer to “Warning list” (page 43). To use an output contact, change the parameter setting, and make sure that the output contact normally operates. (For parameter setting changing procedure, refer to page 28.)

## 1. External input and output circuit

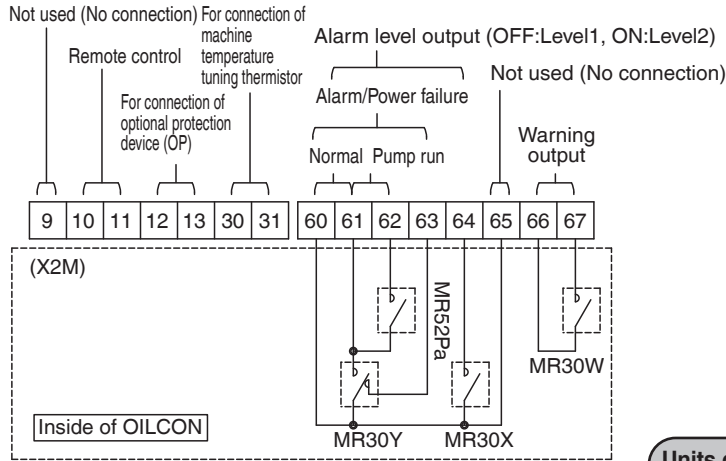

(For alarm levels, refer to page 44.)

**CAUTION**

- The contact capacity is as follows:  
Resistance load: 30 VDC, 2 A
- The minimum allowable load is as follows:  
12 mVDC, 10 μA
- To connect an inductive load, be sure to use a surge absorber.

## 2. Alarm and warning output logic

The alarm and warning output logic can be changed depending on the parameter setting. (See page 15.)

Units digit of alarm and warning output logic parameter (n001)	
0 (Factory setting) [Positive action]	1 [“b” contact]
<p>Normal</p>	<p>Normal or power failure</p>
<p>Alarm or power failure</p>	<p>Alarm</p>

## External output timing chart

When the power supply is turned ON, external output becomes unstable. Set up the main machine sequence program so that the external output signal is ignored for one second after power-ON.

Operation status			Power OFF (including power failure)		Power ON					
			Run	Alarm level 2	Run	Alarm level 1	Run			
Preset condition	Power supply		OFF	ON	Reset	Reset				
	Remote control contact	Between terminals [10]-[11]	ON	OFF						
	Operation panel	Operation lock mode	ON	OFF	ON	ON				
Mode and terminal symbol of external output contact Output logic parameter setting: “0”	Normal (“a” contact)	Between terminals [60]-[61]	OFF	ON						
	Alarm/Stop (Power OFF) (“b” contact)	Between terminals [60]-[63]	ON	OFF						
	Agitator operation/ Pump run (“a” contact)	Between terminals [61]-[62]	OFF	ON	OFF	ON	ON			
	Alarm level	Between terminals [60]-[64]	OFF	ON						
	Alarm (“a” contact)	Between terminals [60]-[61]	OFF	ON	OFF	ON				
	Normal/Stop (Power OFF) (“b” contact)	Between terminals [60]-[63]	ON	OFF	ON	OFF				
	Agitator operation/ Pump run (“a” contact)	Between terminals [61]-[62]	OFF	ON	OFF	ON	ON			
	Alarm level	Between terminals [60]-[64]	OFF	ON						
Signal output			No warning status				Warning status			
			Normal	Alarm level 1 or LOCK	Alarm level 2	Power failure (Power OFF)	Normal	Alarm level 1 or LOCK	Alarm level 2	Power failure (Power OFF)
Warning output (“a” contact)	Output logic parameter setting: “0”	[66]-[67]	ON	OFF						
	Output logic parameter setting: “1”	[66]-[67]	ON	OFF						

## Connection of remote control contact

The component below must be acquired separately

<b>Component</b>	Single-pole, single-throw remote control switch, or “a” contact that enables operation command output (Note) Select a switch whose minimum allowable load is 12 VDC and 5 mA.
------------------	---

### 1. Remove short-circuit wire from [10]-[11] of the signal terminal block

- Refer to page 12 for how to remove.

### 2. Connect a wire, with the above component attached, to [10]-[11] of the signal terminal block

- 12 VDC is applied across these terminals (Terminal [10]: negative polarity, [11]: positive polarity).
- Attach the remote control switch to the main machine.

## Alarm Settings for Optional Protection Devices (Installed by User)

The OILCON can activate an alarm by receiving an output signal from optional protection devices (e.g. flow switch, level switch).

### When using Option OP terminals [12]-[13]:

1. Connect the signal cable of the optional protection device to terminals [12]-[13] on the OILCON signal terminal block. (See “About the electrical equipment box” on page 12.)
2. Set Parameter [n002]. (See page 28.)
  - “0”: OP terminal is not used. (Factory setting)
  - “1”: When OP contact turns OFF, Alarm Level 1 is activated.
  - “2”: When OP contact turns OFF, Alarm Level 2 is activated.
  - “3”: When OP contact is not ON after 30 seconds from pump motor operation start, Alarm Level 1 is activated. (When flow switch is used)
  - “4”: When OP contact continues to be OFF after 5 seconds have passed, Alarm Level 1 is activated. (When level switch is used)

**[CAUTION]** The protection function cannot be activated simply by connecting the protection device to the OP terminals. Be sure to set this parameter.

### When using Option OP 2 terminal [Connector CN2]:

1. Connect the signal cable of the optional protection device to [Connector CN2] on the OILCON control board. (See “About the electrical equipment box” on page 12.) Wiring material: Housing XAP-02V-1, Contact SXA-001T-P0.6
2. Set Parameter [n003]. (See page 28.)
  - “0”: OP2 terminal is not used. (Factory setting)
  - “1”: When OP2 contact turns OFF, Alarm Level 1 is activated.
  - “2”: When OP2 contact turns OFF, Alarm Level 2 is activated.
  - “3”: When OP contact is not ON after 30 seconds from pump motor operation start, Alarm Level 1 is activated. (When flow switch is used)
  - “4”: When OP2 contact continues to be OFF after 5 seconds have passed, Alarm Level 1 is activated. (When level switch is used)

**[CAUTION]** The protection function cannot be activated simply by connecting the protection device to the OP terminals. Be sure to set this parameter.



# Alarm / Warning Output Logic

The operation status of the OILCON can be output.

- The output settings for the alarm (warning) output depend on the value set for parameter number (n001) (\*units digit).

## 1. Wire the signal terminal block

- For the connecting method, refer to “Connection of signal terminal block” on page  12.

## 2. Change the setting value of parameter number (n001)

- The value (\*units digit) set for parameter number (n001) determines the output settings for the alarm (warning) output. Refer to the table below when setting the value (\*units digit).
- Refer to page  28 for how to change parameter settings.
- Changes to setting values require the power to be reset to take effect.

Parameter number (n001) setting		0 (Factory default)			1 (2 to 9: Same operation as with 1)		
	Contact	Normal	Power failure	Alarm	Normal	Power failure	Alarm
Alarm output	[60]-[61]	ON	OFF	OFF	OFF	OFF	ON
	[60]-[63]	OFF	ON	ON	ON	ON	OFF
Warning output	[66]-[67]	ON	OFF	OFF	OFF	OFF	ON

\* Units digit: Sets alarm output logic ([60]-[61], [60]-[63]) and warning output logic ([66]-[67]) of the signal terminal block.

Tens digit: Sets DOUT signal output logic. (Communication expansion board (optional extra) is required.)

# Check Before Operation

Before operating the OILCON, check the following items:

## 1. Operating environment

- Check the atmosphere for any factor (dust, oil mist, high temperature, high humidity, etc.) that may adversely affect the unit.
- Check if the unit is not installed in explosive atmosphere (that may cause evolution, inflow, retention or leak of inflammable gas).
- The operating range is limited. Make sure that the operating conditions are within the following range.  
(Note: If this unit is operated out of the specified range, the protection devices may be activated, or the service life may be shortened.)

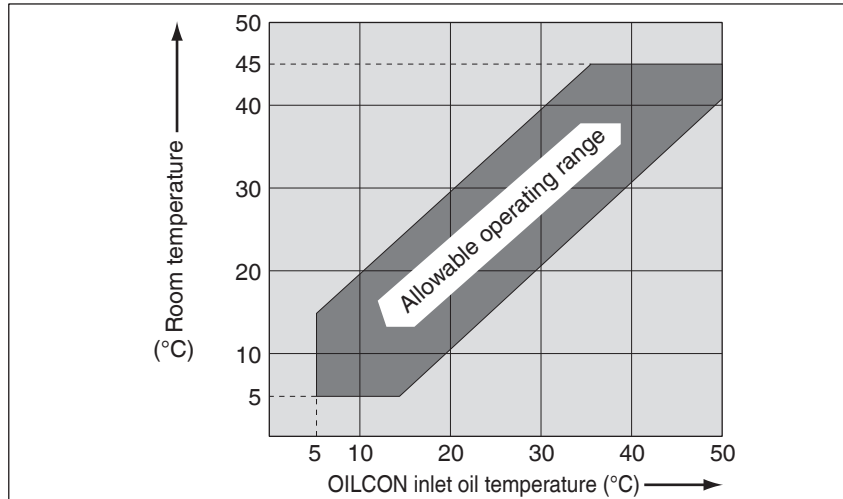

## 2. Installation

- Check if the unit has been securely fastened with bolts or foundation bolts.
- Check for any obstacle that blocks air intake or exhaust flow.  
(Do not put an obstacle within 500 mm from the air intake/exhaust port.)

## 3. Oil piping

- Check the oil piping for leak.
- Check if an appropriate quantity of oil is filled in the tank. (Never run the pump without oil. Otherwise, the pump motor may be damaged.)
- Check if the main machine oil piping is not blocked (fully closed). (If the unit is operated with the main machine oil piping blocked (fully closed), the oil temperature rises, causing an alarm.)
- Check if the pressure loss is within the specified range. (Refer to “Piping” on page 8.)
- Check if the main machine oil piping is equipped with a flow switch.  
(To protect the main machine, it is recommended to mount a flow switch.)

## 4. Applicable oil

- The OILCON is intended for lubrication and hydraulic oils (mineral oils) with an autoignition temperature over 100°C, flash point of 70°C or higher but below 250°C, and a discoloration rating of No.1 according to the “Petroleum Products - Corrosiveness to Copper - Copper Strip Test (ISO 2160/JIS K2513)” as well as a pollution degree of NAS Class 10. The following oils (liquids) cannot be used for this unit.
  1. Flame-resistant hydraulic oil (Phosphoric ester / chlorinated hydrocarbon / water + glycol / W/O, O/W emulsion type oils)
  2. Water and water-soluble liquids
  3. Chemical and food liquids
  4. Cutting oil (fluid) and grinding oil (fluid)
  5. Fuels (kerosene, gasoline, etc.)



### CAUTION

Before operating the OILCON, be sure to read through this instruction manual and understand the contents of this manual.

## 5. Electric wiring

- Check if the cable size is larger than the specified size. (Refer to “Wiring procedure” on page 11.)
- Check if the ground cable is securely connected.
- Be sure to use a commercial power supply. Using an inverter power supply may result in burnout.
- Check that the voltage of the power supply is within the range specified.
- Check if an earth leakage circuit breaker is provided exclusively for each OILCON.

## 6. For customers who use a model on which a pump is not mounted

- For the pump prepared by a customer, it is recommended to use a product equivalent to the specifications shown in the specification list.
- For the power supply, be sure to observe the order of pump ON and OILCON ON.

# Part Names and Functions

**Standard (-B, -C)** (Representative model: AKZ32A)

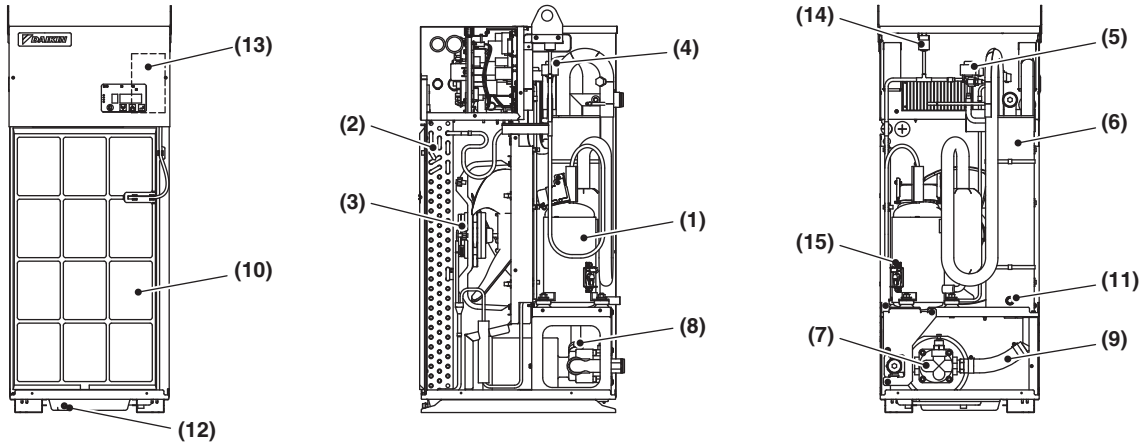

**-H**

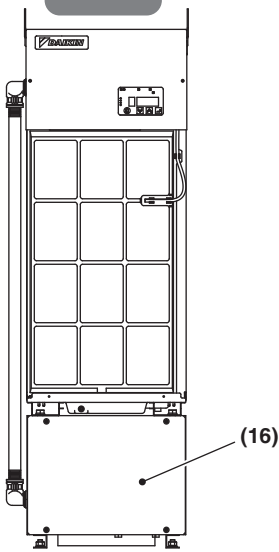

**-T**

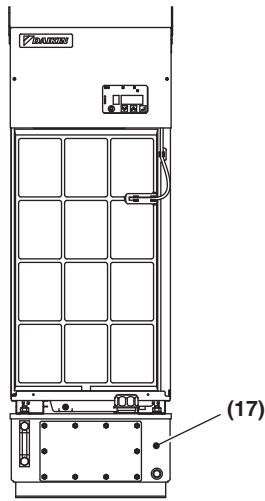

**-048**

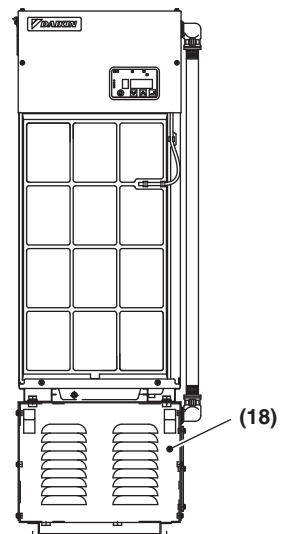

No.	Name	Function	No.	Name	Function
(1)	Compressor	Sucks and compresses the low-temperature, low-pressure gas refrigerant produced in the evaporator, to produce high-temperature, high-pressure gas.	(10)	Air filter	Located at the front of the condenser. It is intended to prevent cooling capacity deterioration by eliminating dust adhering to the condenser from the air intake.
(2)	Condenser	Conducts heat exchange between the high-temperature, high-pressure gas refrigerant produced in the compressor and the air, to produce high-temperature, high-pressure liquid refrigerant.	(11)	Oil drain (Evaporator)	Drains oil from the evaporator when the OILCON is re-located.
(3)	Fan motor (for condenser)	Forcefully blows air to accelerate heat exchange between the refrigerant in the condenser and the air.	(12)	Oil drain (drain pan)	The oil accumulated at the bottom of OILCON can be discharged from here.
(4)	Electronic expansion valve for main circuit	The valve mechanism reduces pressure of the high-temperature, high-pressure liquid refrigerant produced in the condenser, to produce low-temperature, low-pressure liquid/gas mixed refrigerant.	(13)	Circuit breaker ("B" only)	Tripped when over-current flows through the circuit. It is intended to protect the internal electric wiring.
(5)	Electronic expansion valve for hot gases	The cooling capability of low load operation is controlled by bypassing the refrigerant from the high pressure side to the low pressure side.	(14)	High-pressure pressure switch ("C" only)	Tripped when high-pressure alarm is activated. It is intended to protect the refrigerant system for the condenser etc.
(6)	Evaporator	Evaporates the low-temperature, low-pressure liquid refrigerant produced in the expansion valve by conducting heat exchange between the refrigerant and oil, to produce low-temperature, low-pressure gas refrigerant.	(15)	Compressor protection thermostat	Tripped when compressor high-temperature alarm is activated. It is intended to protect the compressor.
(7)	Pump	Sucks oil from outside of the unit, and discharges it from the unit through the evaporator.	(16)	Heater ("H" only)	During warm-up in winter, the electric heater heats up the oil to a preset temperature.
(8)	Relief valve	Limits the pump discharge pressure within a specified level.	(17)	Oil tank ("T" only)	Receives oil from the main machine oil piping system. The oil tank can accept an increase/decrease in oil quantity.
(9)	Rubber hose	A part of the oil piping for discharge of the pump.	(18)	Transformer ("048" only)	Intended for the different-voltage model.

# Outline of control panel

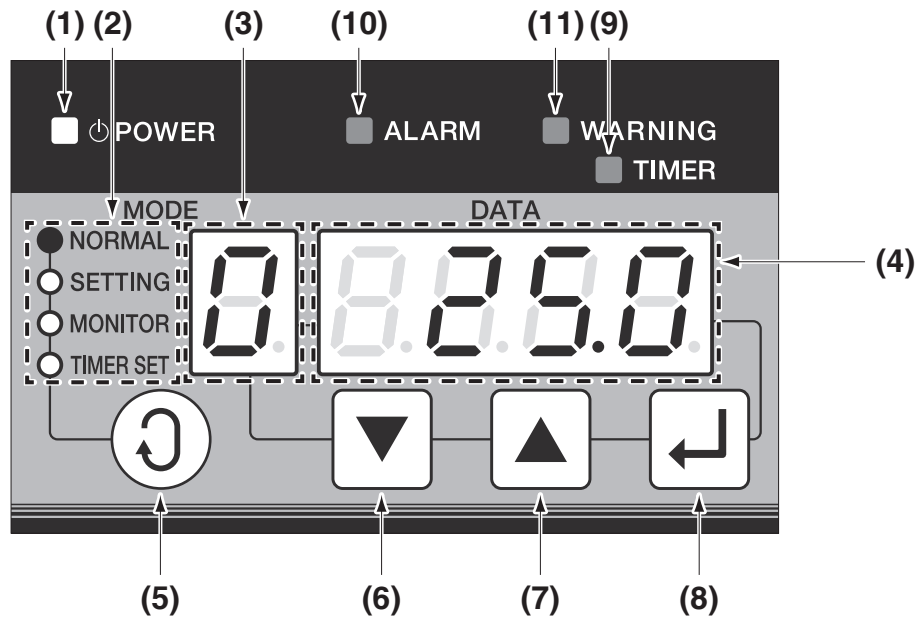

No.	Name	Description	Reference page
(1)	Power lamp (Green)	Lit while power supply is ON.	
(2)	Operation mode indicator	Indicates the control panel operation mode. <b>NORMAL</b> <b>SETTING</b> <b>MONITOR</b> <b>TIMER SET</b>	page  20
(3)	Operation mode/data number display	Display the current operation mode (NORMAL/SETTING), or the data number currently displayed on the data display.	
(4)	Data display	Displays various data. The displayed data vary depending on the operation mode and data number. "ACF" lights for a few seconds after turning OFF the power supply.	
(5)	[SELECT] (selection) key	Used to select each mode.	
(6)	[DOWN] key	Decrements the number of operation mode or data number/value by one. If you keep pressing this key, the number is decremented by ten.	
(7)	[UP] key	Increments the number of operation mode or data number/value by one. If you keep pressing this key, the number is incremented by ten.	
(8)	[ENTER] (registration) key	Registers an operation mode, data number or data changed.	
(9)	Timer mode lamp (Green)	Blinks while the unit is halted in the timer mode.	page  26
(10)	Alarm lamp (Red)	When an alarm is activated: Blinks (Operation stops).....Alarm level 1 Lit (Only the compressor stops).....Alarm level 2	page  40-42
(11)	Warning lamp (Green)	When a warning is activated: Blinks (Serious warning).....Warning level 1 Lit (Minor warning).....Warning level 2	page  43

# Checking Initial Conditions

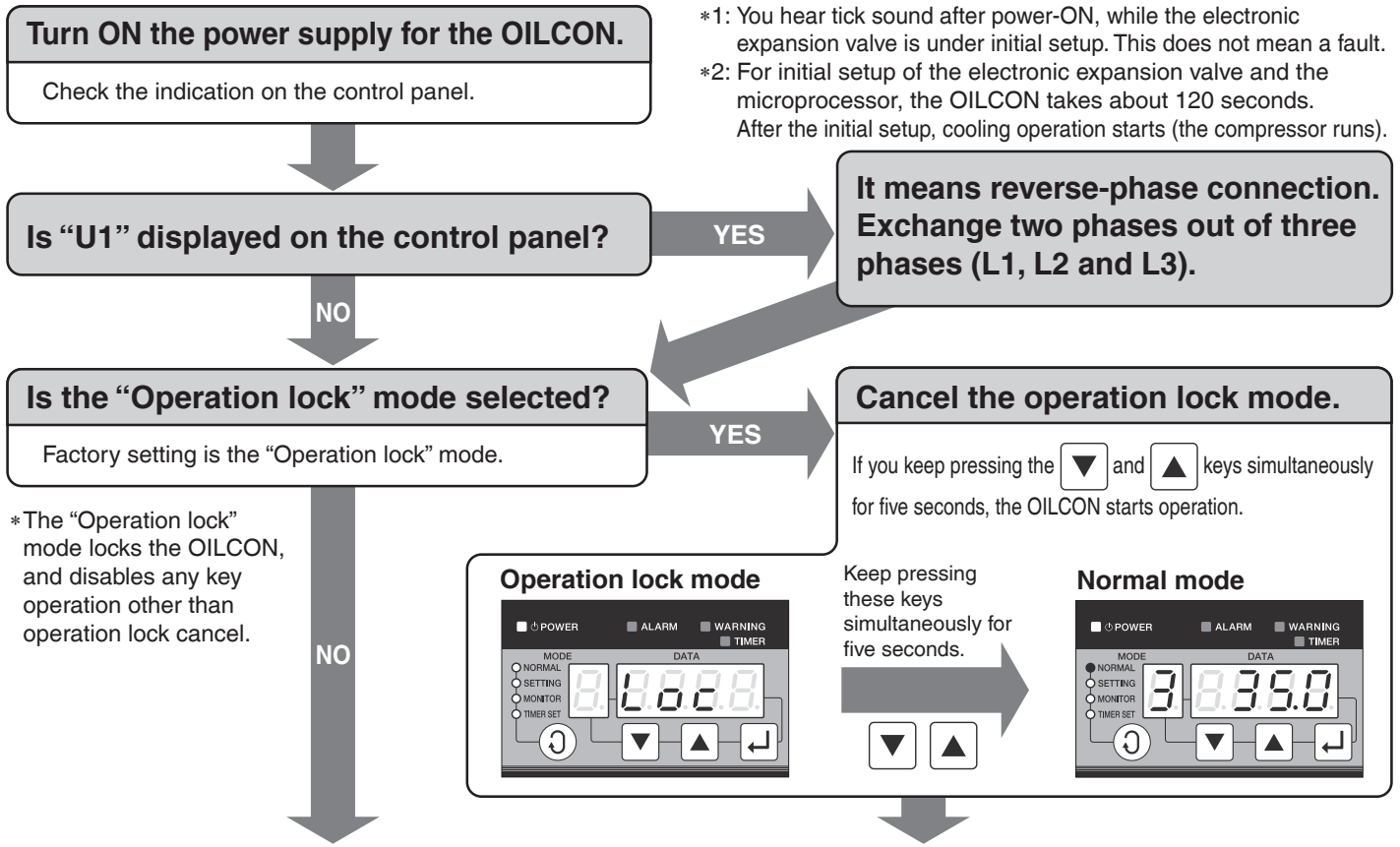

Before Operation Handling

**Check the initial operating conditions.**

Check the current operation settings on the control panel display.

**With the standard model, the factory setting of the operation mode is "3" (Room temperature tuning, Inlet oil temperature control), and the temperature difference is "0.0 (°C)". (With non-standard models, the factory settings may be different from the above.)**

(1) **Operation mode display:** Displays the operation mode.  
(2) **Data display:** Displays the target temperature setting.

Example) Room temperature: 35°C

[See page 21](#)

**Changing operation mode settings**

Hold a constant oil temperature \_\_\_\_\_ [See page 22](#)

Tune the oil temperature to room temperature (or machine temperature) \_\_\_\_\_ [See page 23](#)

Cool the oil at constant capacity (%) \_\_\_\_\_ [See page 24](#)

**AC failure**

When the main power supply is OFF, "ACF" is displayed for a few seconds (during charging of the inverter board, the main power supply is OFF).





# About Operations

Using a mode other than NORMAL, SETTING, MONITOR, or TIMER SET may result in the OILCON malfunctioning, depending on the operation. Please ensure you understand each mode before use.



## Basic Operation

### Operation mode

Operation mode can be changed by pressing the  key on the control panel.

Operation mode	Description	indicator	Reference page
NORMAL	Displays the current operation mode and control target value.	“NORMAL” lamp is lit.	page  19
SETTING	Specifies an operation mode and control target value.	“SETTING” lamp is lit.	page  24
MONITOR	Displays the current value of each thermistor etc.	“MONITOR” lamp is lit.	page  25
TIMER SET	Used to set up time for the ON timer.	“TIMER” lamp is lit.	page  26

### Operation lock mode

- Disables operations of the OILCON regardless of preset conditions.
- The factory setting is the “Operation lock” mode. To start operation, cancel the operation lock mode.
- Pressing the  and  keys simultaneously for five seconds will lock/unlock operation.





(For details, see page  19.)

### Parameter setting mode

- Special functions can be activated by assigning values to parameter numbers (n001-n020).
- [Parameter setting mode] can be turned ON/OFF by pressing the  key for five seconds.

(For details, see page  28.)

### Auto-tuning mode

- This mode is only used when the system of the main machine is generating “unstable temperature control” or “slow response in temperature control”.
- [Auto-tuning mode] can be turned ON/OFF by pressing the   and  keys simultaneously for five seconds. (For details, see page  32.)

### CAUTION

- The factory setting is the “Operation lock” mode.  
To start operation, cancel the operation lock mode.  
(See page  19.)
- With the standard model, the initial operating conditions are as follows:  
Operation mode: 3 (Room temperature tuning, Inlet oil temperature control)  
Temperature difference: 0.0 (°C)

## Control method

In [NORMAL] operation mode, operation is regulated by one of the following control methods: “Fixed temperature control”, “Tuning temperature control”, or “Capacity direct command”. The control method can be selected in [SETTING] operation mode.

The OILCON can operate with the following contents.

Control method	Contents	Reference temperature	Control target* <sup>1</sup>	Operation mode* <sup>3</sup>	Setting range
Fixed temperature control	Hold a constant oil temperature (Keeping a control target at a constant temperature) See page  22.	None	Inlet oil temperature Outlet oil temperature Returned oil temperature* <sup>2</sup>	0 1 1	5.0–50.0 (°C) 5.0–50.0 (°C) 5.0–50.0 (°C)
Tuning temperature control	Tune the oil temperature to room temperature (or machine temperature) (Keeping a constant temperature difference between the control target and the reference temperature) See page  23.	Room temperature  Machine temperature* <sup>2</sup>	Inlet oil temperature Outlet oil temperature Returned oil temperature* <sup>2</sup>  Inlet oil temperature Outlet oil temperature Returned oil temperature* <sup>2</sup>	3 5 5  4 6 6	–9.9–9.9 (°C) –9.9–9.9 (°C) –9.9–9.9 (°C)  –9.9–9.9 (°C) –9.9–9.9 (°C) –9.9–9.9 (°C)
Capacity direct command (used for trial run etc.)	Cool the oil at constant capacity (%) (Executes cooling operation according to capacity command, but disables oil temperature control.) See page  24.	None	None	9	0–100 (%)

\*1: For control target measuring points, see the figure below.

\*2: Optional function using optional parts

\*3: Operation modes 2, 7 and 8 cannot be used.

## System outline drawing

The oil cooling system of the OILCON is as shown below.

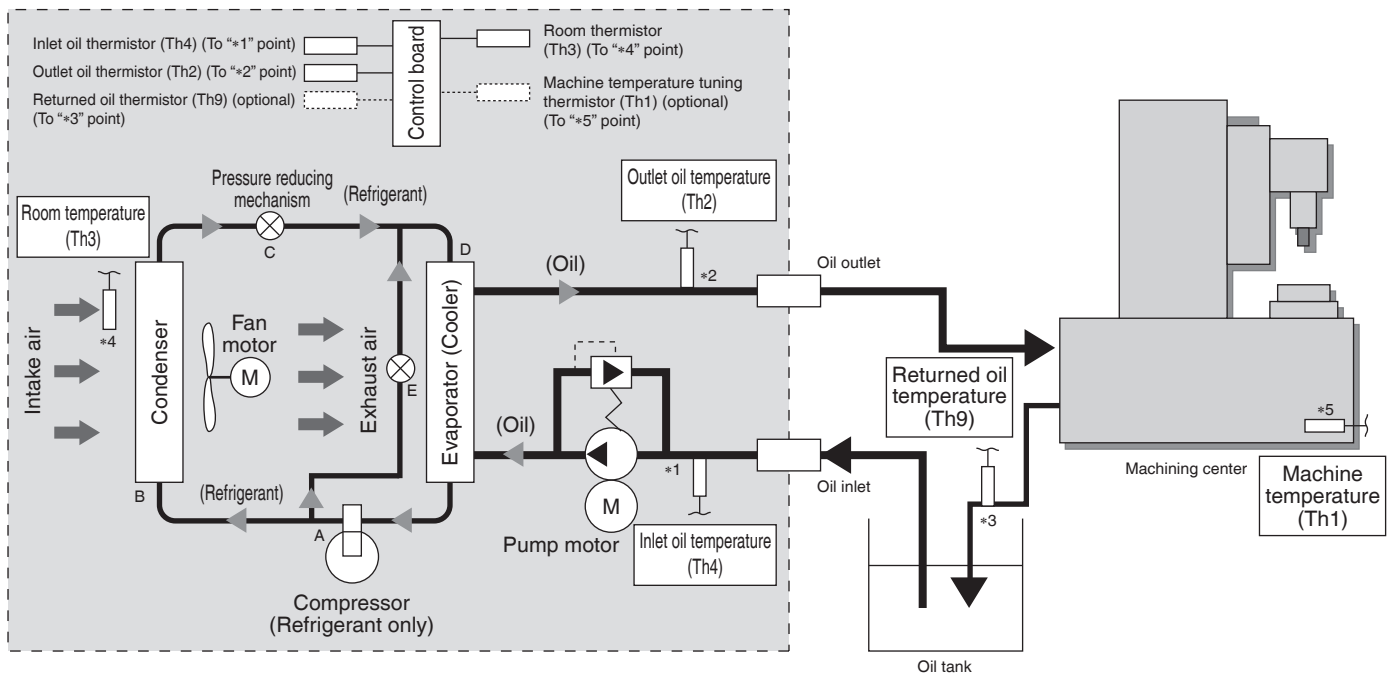

### Description on the refrigerating cycle

- A: The compressor produces high-temperature, high-pressure compressed gas so that the refrigerant gas can be easily cooled and liquefied in the condenser.
- B: The condenser cools and condenses the high-temperature, high-pressure gas produced in the compressor, to transform it to high-temperature, high-pressure liquid.
- C: The pressure reducing mechanism throttles the high-temperature, high-pressure liquid to reduce pressure, and transform it to low-temperature, low-pressure liquid/gas mixture so that it can be easily evaporated in the evaporator.
- D: The evaporator evaporates the low-temperature, low-pressure liquid/gas mixture produced in the pressure reducing mechanism by absorbing heat from the oil (by cooling the oil), and transforms it to low-temperature, low-pressure gas.
- E: Bypass mechanism controls the cooling capability under lower load by adjusting the flow rate of high temperature/high pressure gases to be distributed to the evaporator.

# Hold a Constant Oil Temperature

“Hold a constant oil temperature” has the following 2 operation modes.  
Select with the setting method “2. Select the operation mode”.

Operation mode	Control target
0	Inlet oil temperature
1	Outlet oil temperature Returned oil temperature*

\* Optional function using optional parts. See page 36.

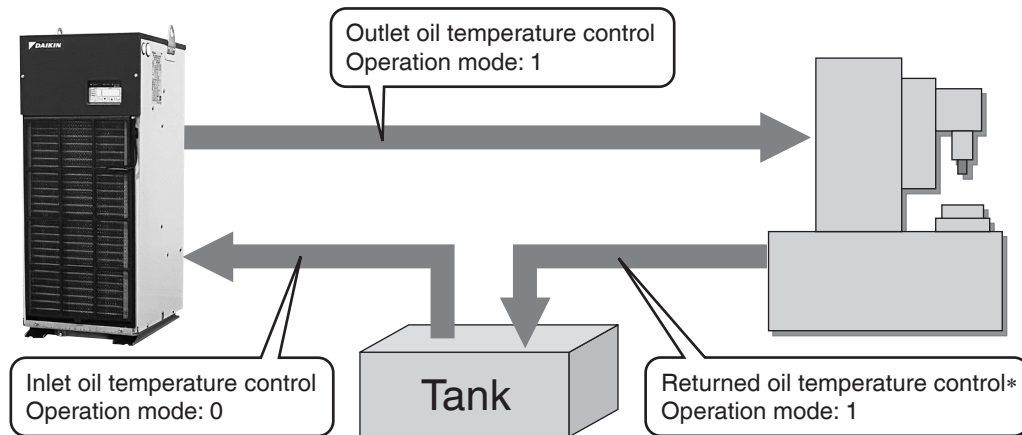

## Setting procedure

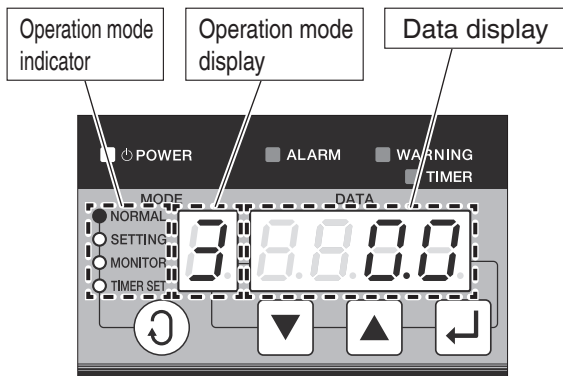

Factory setting  
(With non-standard models, the settings may be different from the above.)

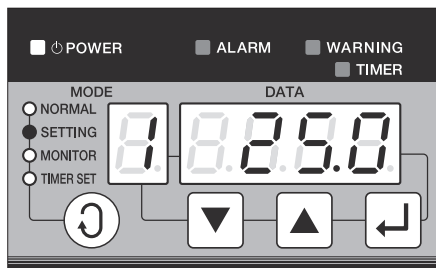

Example) Outlet oil temperature,  
Fixed temperature control  
(Temperature setting: 25°C)

### 1. Change to the operation mode “SETTING”

- Press the key to select “SETTING”.
- \* See “Operation mode” on page 20
- ➔ The “SETTING” lamp on the operation mode indicator lights.
- ➔ The number on the operation mode display blinks.

### 2. Select the operation mode

- Change the number on the operation mode display to “0” or “1” with the key.
- After changing the number, press the key to register it.
- ➔ After the number is registered, the number on the data display blinks.

### 3. Change the set temperature of the oil temperature

- Change the number on the data display with the key.
- Press the key to register the number.
- ➔ After the number is registered, the number on the operation mode display blinks.
- ➔ The number on the data display lights.

### 4. Return to operation mode “NORMAL”

- Press the key 3 times to select “NORMAL”.
- ➔ The “NORMAL” lamp on the operation mode indicator lights.



# Tune the oil temperature to room temperature (or machine temperature)

“Tune the oil temperature to room temperature (or machine temperature)” has the following operation modes. Select with the setting method “2. Select the operation mode”.

Operation mode	Control method
3	Tune the inlet oil temperature to the room temperature
4	Tune the inlet oil temperature to the machine temperature*
5	Tune the outlet (returned*) oil temperature to the room temperature
6	Tune the outlet (returned*) oil temperature to the machine temperature*

\* Optional function using optional parts. See page [35-36](#).

With the above operation settings, the OILCON controls the oil temperature so as to keep the **difference** between the room or machine temperature (reference temperature) and the oil temperature (control target) at a constant value as the user specified, according to a change in the room or machine temperature. The temperature difference setting range is  $-9.9$  to  $+9.9$  ( $^{\circ}\text{C}$ ).

## Setting procedure

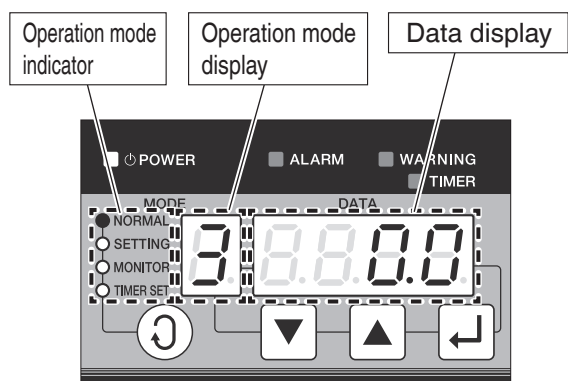

Factory setting  
(With non-standard models, the settings may be different from the above.)

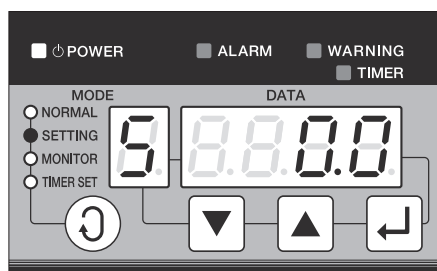

Example) Outlet oil temperature,  
Room temperature tuning control  
(Temperature difference setting:  $0.0^{\circ}\text{C}$ )

### 1. Change to the operation mode “SETTING”

- Press the key to select “SETTING”.
- \* See “Operation mode” on page [20](#)
- ➔ The “SETTING” lamp on the operation mode indicator lights.
- ➔ The number on the operation mode display blinks.

### 2. Select the operation mode

- Change the number on the operation mode display to “3”, “4”, “5” or “6” with the key.
- After changing the number, press the key to register it.
- ➔ After the number is registered, the number on the data display blinks.
- ➔ The number on the operation mode display lights.

### 3. Change the set value of the oil temperature

- Change the number on the data display with the key.
- Press the key to register the number.
- ➔ After the number is registered, the number on the operation mode display blinks.
- ➔ The number on the data display lights.

### 4. Return to operation mode “NORMAL”

- Press the key 3 times to select “NORMAL”.
- ➔ The “NORMAL” lamp on the operation mode indicator lights.

# Cool the Oil at Constant Capacity (%)

“Cool the oil at constant capacity (%)” has the following operation modes.  
Select with the setting method “2. Select the operation mode”.

Operation mode	Control method
9	Cool the oil at constant capacity (%)

With this operation mode, the OILCON executes cooling operation according to the specified capacity command (%), so oil temperature control is disabled.

Set the capacity from 0 to 100% with the setting method “3. Change the set value”.

- \* The capacity (%) is an approximate index.
- \* When the capacity is set to “0%”, the compressor stops. (The pump motor and fan motor are running.)
- \* Even if the capacity command value is same, the actual cooling capacity varies depending on the room temperature and the inlet oil temperature.

## CAUTION

Extra care should be taken as oil temperature is not regulated in operation mode: 9, which could result in serious damage (burn damage etc., to spindle etc.) to machine.

## Setting procedure

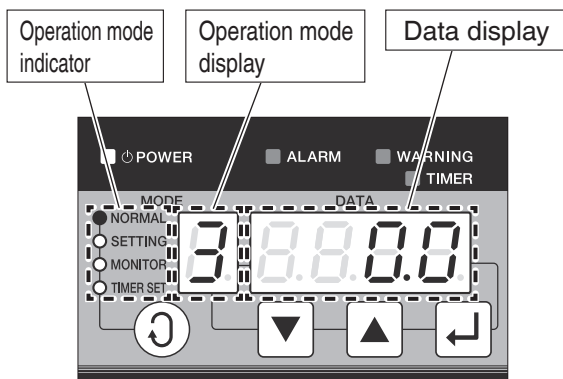

Factory setting  
(With non-standard models, the settings may be different from the above.)

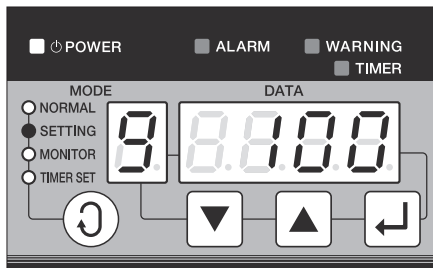

Example) Capacity direct command  
(Capacity setting: 100%)

### 1. Change to the operation mode “SETTING”

- Press the key to select “SETTING”.  
\* See “Operation mode” on page 20
- ➔ The “SETTING” lamp on the operation mode indicator lights.
- ➔ The number on the operation mode display blinks.

### 2. Select the operation mode

- Change the number on the operation mode display to “9” with the key.
- After changing the number, press the key to register it.
- ➔ After the number is registered, the number on the operation mode display lights.
- ➔ The number on the data display blinks.

### 3. Change the set value

- Change the number on the data display with the key.  
\* The capacity setting range of the number is 0 to 100%.
- Press the key to register the number.
- ➔ After the number is registered, the number on the operation mode display blinks.
- ➔ The number on the data display lights.

### 4. Return to operation mode “NORMAL”

- Press the key 3 times to select “NORMAL”.
- ➔ The “NORMAL” lamp on the operation mode indicator lights.

# Monitor Items

When the “Monitor mode” is selected, the following items can be checked.

No.	Description	Note
0	Machine temperature [Th1]	*1
1	Outlet oil temperature or returned oil temperature [Th2]	*1
2	Room temperature [Th3]	*1
3	Inlet oil temperature [Th4]	*1
4	Reserve [Th5]	*1
5	$\Delta T$ (Th4–Th2)	*1
6	Capacity command value (%)	–
7	Compressor inverter rotation speed (rps)	–
8	Power consumption (kW)*	*2
9	Status of expansion DIN (hundreds digit)/DOUT (tens digit)	*3

\*1: Nos. 0, 1, 2, 3 and 5 indicate a temperature detected with each thermistor.

When the relevant thermistor is not connected or has a wire break, “–99.9” is displayed.

\*2: This value is calculated under the conditions; power supply voltage 200 V and pump discharge pressure: 0.2 MPa (VG32: oil temperature 25°C). (Accuracy is approximately  $\pm 20\%$  for max. power consumption.)

For models not equipped with a pump, contact us separately.

\*3: With the factory setting, “0” is displayed. However, the indication will become valid when the parameter n020 is “1” or optional parallel communication PCB is installed.

## Operating procedure

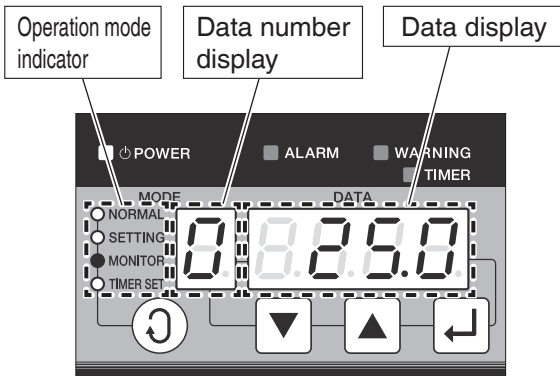

### 1. Change to the operation mode “MONITOR”

- Press the key to select “MONITOR”.

\* See “Operation mode” on page [20](#)

- ➔ The “MONITOR” lamp on the operation mode indicator lights.
- ➔ The number on the data number display blinks.

### 2. Select the item to monitor

- Change the number on the data number display with the key.

- ➔ When the data number is changed, the temperature currently detected with the thermistor and input values simultaneously appear on the data display.

### 3. Return to operation mode “NORMAL”

- Press the key 2 times to select “NORMAL”.

- ➔ The “NORMAL” lamp on the operation mode indicator lights.

# Timer Operation

With the “ON” timer, the OILCON can be started after elapse of a desired time. This mode can be used to warm up the main machine.

The operation start time setting range is 0 to 999 hours (in one hour steps).

- \* While the timer mode is selected, keep the main power supply ON.  
The value indicated on the control panel will be decremented from a preset value at one-hour intervals.
- \* To cancel the timer mode, set the timer at “0”.
- \* The timer setting is active only once. To use the timer again, you must set up the timer again.

## Operating procedure

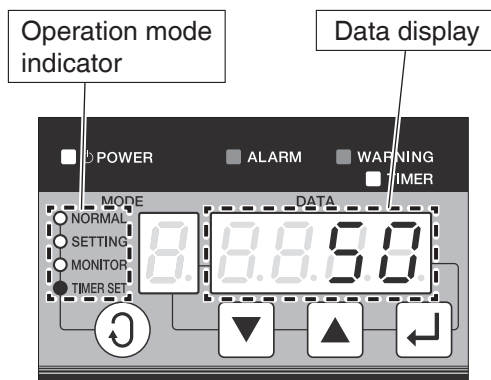

### 1. Change to the operation mode “TIMER SET”

- Press the key to select “TIMER SET”.  
\* See “Operation mode” on page 20
- ➔ The “TIMER SET” lamp on the operation mode indicator lights.
- ➔ “0” blinks on the data display.

### 2. Specify an operation start time

- Change the number on the data display with the key.  
\* The unit of set value is “hour”.

### 3. Set up the timer

- Press the key to register the number.
- ➔ When the timer is activated, the OILCON is halted.
- ➔ The value on the data display blinks.
- ➔ The “TIMER” lamp blinks.
- Keep the main power supply ON.

## Main machine warm-up

With the built-in heater model (-H), the electric heater heats up oil to a preset temperature during main machine warm-up in winter. Combining this function with timer operation enables more effective warm-up.

Heater ON: When inlet oil temperature is at least 0.5°C lower than preset temperature

Heater OFF: When inlet oil temperature is equal to, or higher than preset temperature

Regardless of the operation mode, the OILCON turns ON/OFF the heater by detecting the inlet oil temperature.

(\* Only when the compressor is not in operation)

Note that the heater cannot perform high-precision oil temperature control.







<Usage example>

If the operation start time is set to “10” (hour) by operation mode “TIMER SET” on a certain day at 20:00, warm-up will begin the following day at 6:00.

# About Special Functions



You can additionally set up the following functions by setting the parameters of the OILCON.

## 1. Contents of special functions

- Auto-tuning: The OILCON control will set P and I gain parameters according to the system behavior.  page  32
- Temperature range warning: Activates warning output when oil temperature exceeds preset temperature range.  page  29
- Alarm/warning output logic: Outputs signal from OILCON to main machine.  page  15
- Communication with main machine: Enables communication with main machine when optional board is mounted (see page  37).

## 2. Parameter list

The parameters (No.) that must be specified for individual special functions are listed below.

Special functions	No.	Item	Minimum value	Maximum value	Initial value (Factory setting)	Unit	Necessity of power supply reset	Remarks
–	n000	Not used	0	0	0	–		
Alarm output logic	n001	Alarm and warning output logic	0	11	0	–	○	See page  15.
	n002	OP contact level	0	4	0	–		
	n003	OP2 contact level	0	4	0	–		
Auto-tuning	n004	Outlet oil temperature decrease (Auto-tuning end condition)	0.0	10.0	8.0	°C		For auto-tuning See page  32.
	n005	P/I gain calculation coefficient (Response coefficient)	0.1	10.0	2.0	–		
	n006	Control gain P (for low deviation)	1	999	(40)	–		• The initial value varies depending on the model. (Automatically set up by auto-tuning)
	n007	Control gain I (for low deviation)	1	999	(40)	–		
	n008	Control gain P (for high deviation)	1	999	(40)	–		
n009	Control gain I (for high deviation)	1	999	(40)	–			
Temperature range warning	n010	Warning setting 1	0	465	0	–		See page  29.
	n011	Warning setting data 1	0.0	60.9	0.0	–		
	n012	Warning setting 2	0	465	0	–		
	n013	Warning setting data 2	0.0	60.9	0.0	–		
	n014	Warning setting 3	0	465	0	–		
	n015	Warning setting data 3	0.0	60.9	0.0	–		
	n016	Warning setting 4	0	465	0	–		
	n017	Warning setting data 4	0.0	60.9	0.0	–		
	n018	Warning setting 5	0	465	0	–		
n019	Warning setting data 5	0.0	60.9	0.0	–			
Communication with main machine	n020	Use of parallel communication	0	1	0	–	○	
–	n021 to n038		–	–	–	–		Never attempt to change these settings. Otherwise, the unit may malfunction.

### 3. Parameter setting procedure

With parameter setting, you can enable special functions of the OILCON.

For description of the special functions and parameter list, refer to page 27.

## Setting procedure

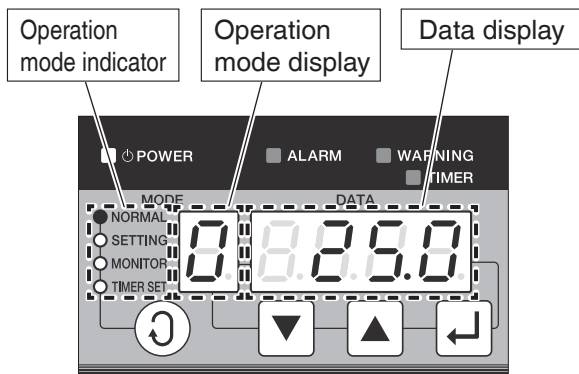

#### 1. Change from operation mode to parameter setting mode

- Enter parameter setting mode by pressing and holding the key for 5 seconds.

\* See "Operation mode" on page 20

- ➔ The "SETTING" lamp on the operation mode indicator blinks.
- ➔ "P" on the operation mode display blinks.

#### 2. Select a parameter number

- Select a desired parameter number with the key.
- ➔ After parameter number "n000" is displayed on the data display for approx. 0.5 seconds, that setting value is displayed.
- After changing the parameter number, press the key to register it.
- ➔ After the number is registered, the number on the data display blinks.

#### 3. Change the set value

- Change the number on the data display with the key.
- Press the key to register the number.
- ➔ After the number is registered, the number on the data display lights.
- ➔ "P" on the operation mode display blinks.

#### 4. Return to operation mode "NORMAL"

- Press the key to select "NORMAL".
- ➔ The "NORMAL" lamp on the operation mode indicator lights.

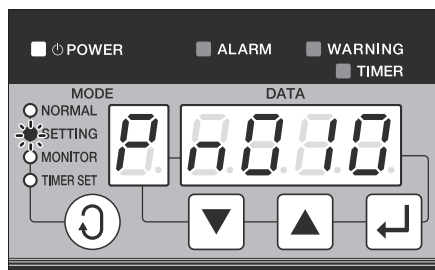

After the selected parameter number is displayed for approx. 0.5 seconds, that set value appears.

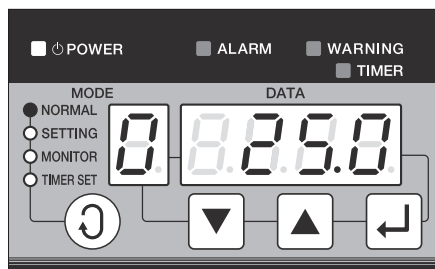
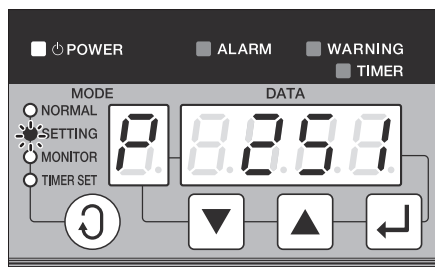

# Setting Special Function—“Temperature range warning”

## ■ Outline of the function

- As a special function of the OILCON, you can set up the “**Temperature range warning**” function. This function allows you to specify a desired temperature range within the OILCON operating range. When the control temperature exceeds the preset range, the unit informs you of the “Temperature range warning” condition.
- The operation at the time of temperature range warning activated can be selected by setting (Operation mode after temperature range warning is activated (c) on page [30](#) ).

## ■ Parameter setting

- For temperature range warning, up to 5 settings are available as shown in the table here below. Also, input the set value for each parameter number to set the warning occurrence condition.

(Refer to “Parameter setting procedure” on page [28](#) )

Item	Monitoring target and operation setting		Operation temperature setting		Display	
	Parameter number	Set value	Parameter number	Set value	Warning	Alarm
(1)	n010	a,b,c	n011	d,e	1E	F1
(2)	n012		n013		2E	F2
(3)	n014		n015		3E	F3
(4)	n016		n017		4E	F4
(5)	n018		n019		5E	F5

\* The “monitoring target and operation” set value is composed of “monitoring target (a)”, “comparison target (b)”, and “operation at time of warning occurrence (c)”.

\* The “operation temperature” set value is composed of “warning temperature (d)” and “differential value (e)”.

## Example of temperature range warning

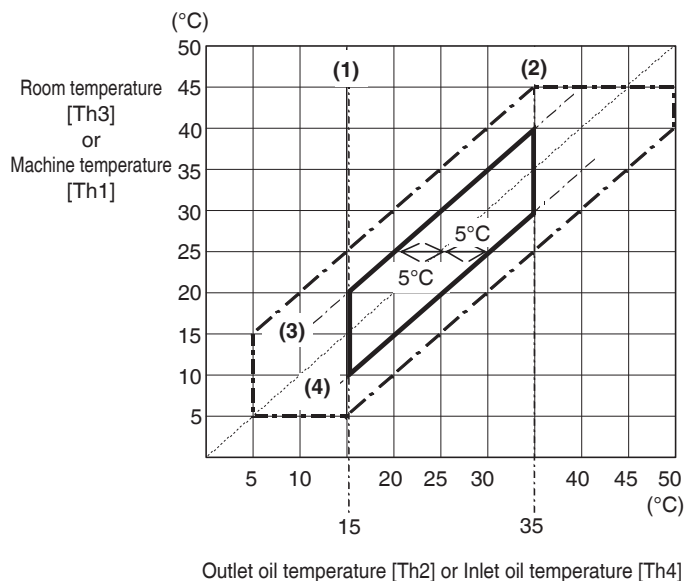

: OILCON operating range

: Temperature range warning setting

- When the outlet oil temperature [Th2] (or inlet oil temperature [Th4]) is 15°C or lower, the compressor stops. (Warning)
- When the outlet oil temperature [Th2] (or inlet oil temperature [Th4]) is 35°C or higher, the compressor stops (F1 to F5 alarm), and terminal [66]-[67] output turns ON or OFF.
- When the outlet oil temperature [Th2] (or inlet oil temperature [Th4]) is at least 5°C lower than the room temperature [Th3] (or machine temperature [Th1]), terminal [66]-[67] output turns ON or OFF.
- When the outlet oil temperature [Th2] (or inlet oil temperature [Th4]) is at least 5°C higher than the room temperature [Th3] (or machine temperature [Th1]), terminal [66]-[67] output turns ON or OFF.

■ About monitoring target and operation (a) (b) (c) settings

\* To avoid a temperature range warning during setting, input the following items (d) and (e) before setting (a), (b) and (c).

(1) Set the “temperature range warning temperature (d)” with “monitoring target (a)” and “comparison target (b)” based on the following formula.

$$\text{Settings for monitoring target (a)} \times \text{Settings for comparison target (b)} \geq (*1) \times \text{Temperature range warning temperature (d)}$$

\*1: When the setting No. of comparison target (b) is 5 or 6, it becomes “≥ fixed value” or “≤ fixed value”.

(2) Set “operation at time of warning (c)”.

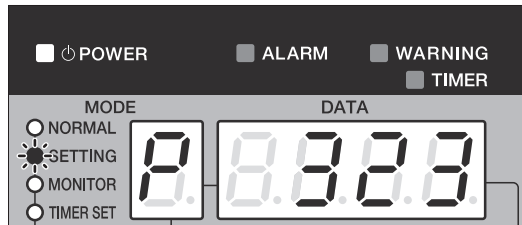

(a) (b) (c)

Monitoring target (a)

Setting No.	Settings
0	(Without using the warning function)
1	Machine temperature (Th1) *2
2	Outlet oil temperature (Th2) *3
3	Room temperature (Th3)
4	Inlet oil temperature (Th4)

Comparison target (b)

Setting No.	Settings
0	(Without using the warning function)
1	-Machine temperature (Th1)
2	-Outlet oil temperature (Th2)
3	-Room temperature (Th3)
4	-Inlet oil temperature (Th4)
5	≥ fixed value
6	≤ fixed value

\*2: The machine temperature tuning thermistor option is required.

\*3: Use this setting No. also for the returned oil thermistor option.

Operation mode after temperature range warning is activated (c)

Setting No.	Display	Compressor start/stop and reset method		External output (*4)	
				Terminal [60]-[61]/[60]-[63]	Terminal [66]-[67]
0	(Without using the warning function)				
1	Warning (1E to 5E) display	Operation		No output	Output
2		Compressor only forced stop	Automatic reset		No output
3			Manual reset (power supply is turned ON again)		Output
4	Alarm (F1 to F5) display	Compressor only forced stop	Automatic reset	Output	No output
5			Manual reset (power supply is turned ON again)		Output

\*4: Output to the external terminal follows the parameter setting n001 in accordance with page 15.



■ Parameter (d) (e) settings

(3) Set the following “differential value (e)” to specify the reset temperature at which to release the temperature range warning.

$$\boxed{\text{Return temperature or return temperature difference}} = \boxed{\text{Temperature range warning temperature (d)}} - (*5) \boxed{\text{Differential value (e)}}$$

\*5: However, when the comparison target (b) is “≤ fixed value”, it becomes “+”.

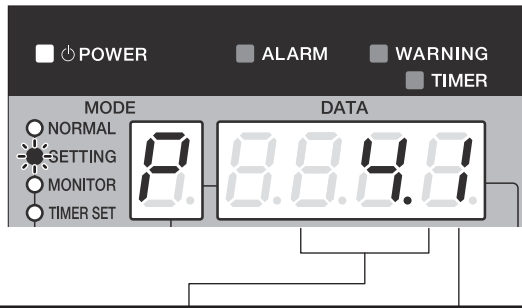

Parameter number	Temperature range warning temperature (d) or the temperature difference		Differential value (e) Set temperature difference for automatic reset *6
	Tens place	Ones place	First decimal place
n011	0 to 60 (°C)		1 to 9 (°C)  Note) 0.1 (°C) when it is 0
n013			
n015			
n017			
n019			

\*6: When the operation at time of temperature range warning (c) is set to 4 or 5, it is invalid because it does not automatically reset.

■ Temperature range warning setting example

**Example of parameter settings (for temperature range warning: See page 29.)**

(1)	When the outlet oil temperature [Th2] (or inlet oil temperature [Th4]) is 15°C or lower, the compressor stops. (Warning)	n010	262 (462)
(2)	When the outlet oil temperature [Th2] (or inlet oil temperature [Th4]) is 35°C or higher, the compressor stops (F1 to F5 alarm), and terminal [66]-[67] output turns ON or OFF.	n012	255 (455)
(3)	When the outlet oil temperature [Th2] (or inlet oil temperature [Th4]) is at least 5°C lower than the room temperature [Th3] (or machine temperature [Th1]), terminal [66]-[67] output turns ON or OFF.	n014	121 (141)
(4)	When the outlet oil temperature [Th2] (or inlet oil temperature [Th4]) is at least 5°C higher than the room temperature [Th3] (or machine temperature [Th1]), terminal [66]-[67] output turns ON or OFF.	n016	211 (411)

**Example of parameter settings (for temperature range warning: See page 29.)**

(1)	When the outlet oil temperature [Th2] (or inlet oil temperature [Th4]) is 15°C or lower, the compressor stops. (Warning) [When outlet oil temperature [Th2] becomes 17°C, the warning status will be automatically reset.]	n011	15.2*7
(2)	When the outlet oil temperature [Th2] (or inlet oil temperature [Th4]) is 35°C or higher, the compressor stops (F1 to F5 alarm), and terminal [66]-[67] output turns ON or OFF.	n013	35.0
(3)	When the outlet oil temperature [Th2] (or inlet oil temperature [Th4]) is at least 5°C lower than the room temperature [Th3] (or machine temperature [Th1]), terminal [66]-[67] output turns ON or OFF. [When the difference between room temperature [Th3] and outlet oil temperature [Th2] becomes 4°C or less, the warning status will be automatically reset.]	n015	5.1*8
(4)	When the outlet oil temperature [Th2] (or inlet oil temperature [Th4]) is at least 5°C higher than the room temperature [Th3] (or machine temperature [Th1]), terminal [66]-[67] output turns ON or OFF. [When the difference between room temperature [Th3] and outlet oil temperature [Th2] becomes 3°C or less, the warning status will be automatically reset.]	n017	5.2*9

\*7: 17 (Temperature range warning reset temperature) – 15 (Temperature range warning temperature) = 2

\*8: 5 (Temperature range warning temperature) – 4 (Temperature range warning reset temperature) = 1

\*9: 5 (Temperature range warning temperature) – 3 (Temperature range warning reset temperature) = 2

# For Temperature Control Improvement—“Auto-tuning mode”

\* To use the OILCON in normal conditions, this function is not required.

## ■ Outline of the function

Depending on the system of the main machine, problems of “unstable temperature control” or “slow response in temperature control” may be raised. In such cases, it is possible that the temperature control gain\* P or I setting is not suitable for the system.

\* Temperature control gain: Coefficient to determine a control value according to deviation (temperature difference)

P: Proportional gain

I : Integral gain

In such cases, you can improve the temperature control performance by using the “Auto-tuning mode” that provides more suitable gain settings.

### Auto-tuning (Conceptual drawing)

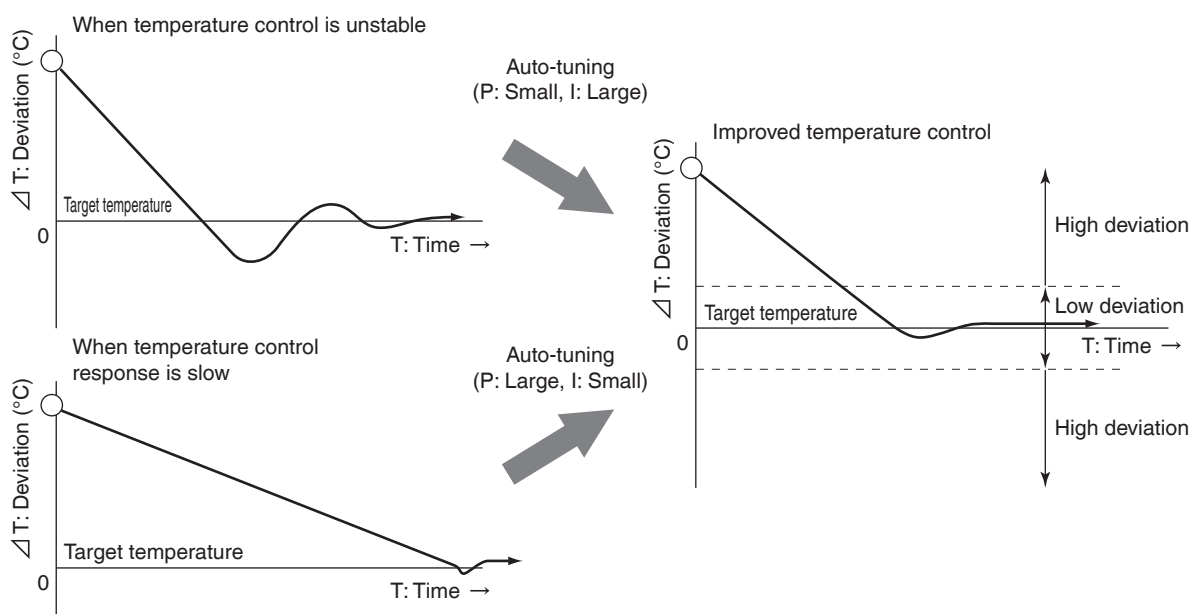

Parameter No.	Item
n005	P/I gain calculation coefficient (Response coefficient)
n006	Temperature control gain P (for low deviation)
n007	Temperature control gain I (for low deviation)
n008	Temperature control gain P (for high deviation)
n009	Temperature control gain I (for high deviation)

The auto-tuning mode automatically writes calculated values of temperature control gain (P and I) into specified parameters.

Initial value: 2.0

Calculated temperature control gain P

Calculated temperature control gain I

■ Factory settings of the standard model  
P: 40  
I: 40

## ■ Outline of operation

The auto-tuning mode executes the following steps.

Check the OILCON status in each step.

Step	Operation	Unit status	Remarks
Before start	—	Operation status (Operation mode: Other than 9)	Select a desired operation mode. *[Note] 1., 3.
Step 0	Checking tuning conditions	Operation status (Operation mode: Other than 9: Same as before start)	
Step 1	Operation for stabilizing initial status	Operation status (Automatic operation for 2 minutes at 1% capacity)	
Step 2	Operation for collecting control target data	Operation status (Automatic operation for 10 minutes at 100% capacity)	*[Note] 4.
Step 3	Calculation of temperature control gain P and I from collected data, and writing gain into each parameter	Stop	*[Note] 5.
After completion	—	Stop	*[Note] 6.

# Operation flow

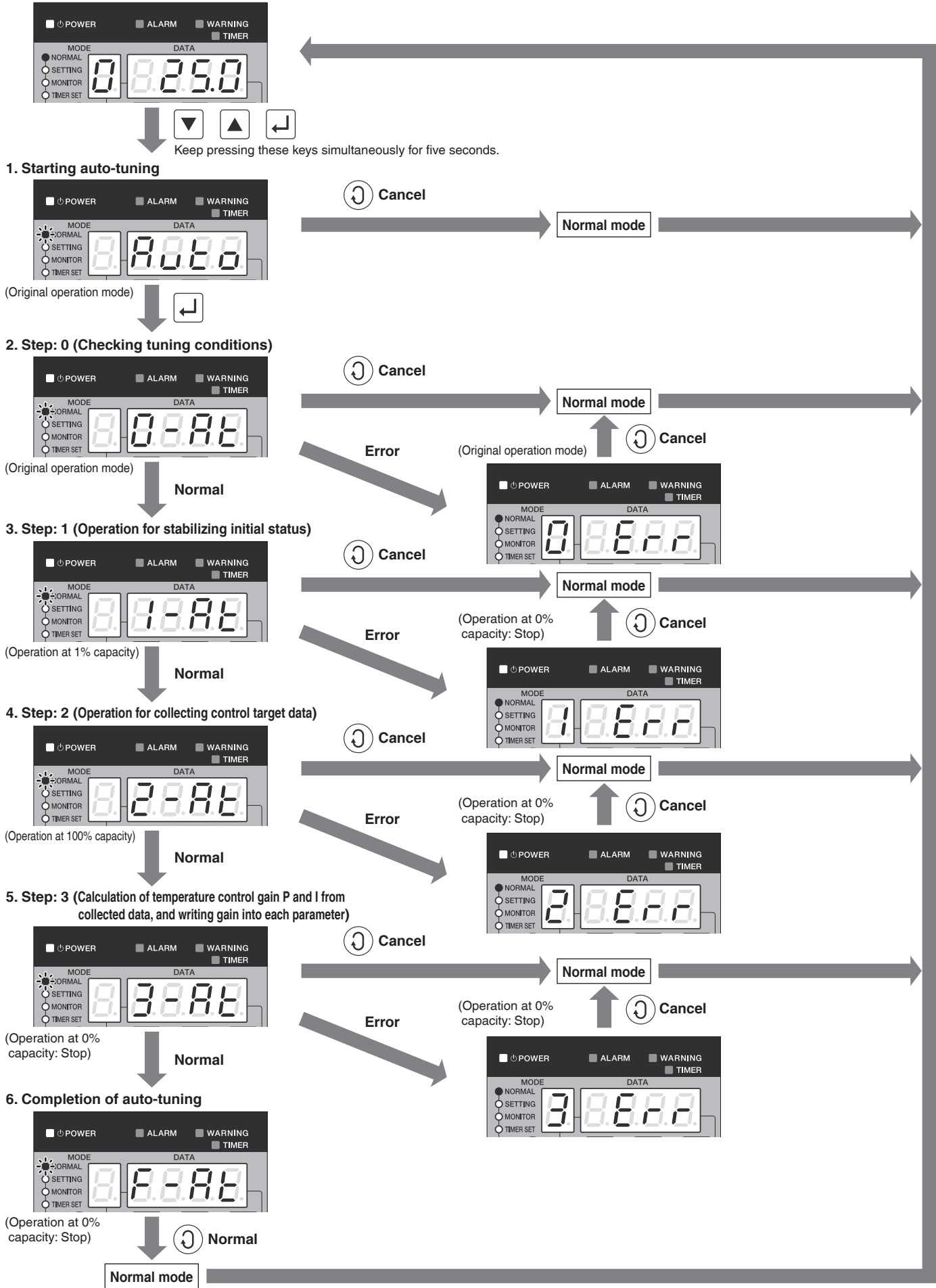

Useful Functions

[Note]

1. When starting auto-tuning, make sure that **the oil temperature is nearly equal to the room temperature (in stable condition)**.  
Leave the main machine under no load (stopped).  
To complete the auto tuning correctly, start the auto tuning after the power supply to OILCON is turned ON more than 5 minutes.
2. If **the remote signal turns OFF or an alarm is activated** during execution of auto-tuning, an error occurs (auto-tuning cannot be executed), and the corresponding error message appears.  
To cancel the error, press the  key. (The unit returns to the normal mode.)  
Check the remote signal, or examine the cause of the alarm. After taking a corrective action, execute auto-tuning again.
3. Before starting auto-tuning, select an operation mode to determine the control target thermistor. (Select any operation mode other than "9".)  
Operation mode 0, 3 or 4  $\Rightarrow$  Inlet oil thermistor  
Operation mode 1, 5 or 6  $\Rightarrow$  Outlet oil thermistor  
Then, set Parameter [n004] by referring to [Note] 4. below.
4. In Step 2, the machine may be over-cooled. To suppress machine over-cooling, specify an auto-tuning end condition in Parameter [n004].

**Parameter [n004] Outlet oil temperature decrease (Auto-tuning end condition)**

**Setting range: 0.0 to 10.0°C, Initial value: 8.0°C**

When the outlet oil temperature decreases by the temperature specified in this parameter, auto-tuning (data collection) ends.

If the specified temperature range is too small, temperature control gain may not be correctly calculated. You should set this parameter to the maximum value in the range where it does not cause damage to the machine.

5. First, execute auto-tuning with the initial value of 2.0.  
To calculate more suitable temperature control gain based on the data collected in Step 3, you must specify a response coefficient in Parameter [n005].  
Setting this response coefficient to a smaller value improves stability, while setting to a larger value improves response speed.

**Parameter [n005] P and I gain calculation coefficient (Response coefficient)**

**Setting range: 0.1 to 10.0, Initial value: 2.0**

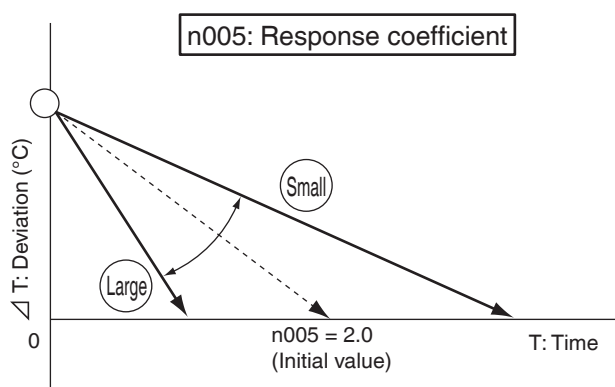

6. Depending on the condition of the control target (machine), the unit may not calculate suitable temperature control gain in a single auto-tuning operation. You should **execute auto-tuning two or three times to average the calculated values, or use the value that most frequently appears (except for an extreme value)**.  
To calculate a more suitable temperature control gain, you may change Parameter [n005] (see [Note] 5. above).
7. The temperature control will not be stabilized when the load changes abruptly (transient period).

# Optional Parts (Sold Separately)

## Machine temperature tuning control

See page 21.

When the following optional parts are mounted to the main machine, the OILCON can perform control by detecting the machine temperature.

### Optional Parts

Name	Type	Lead wire length L (m)	Dimensions	Application (Installed by user)	Compatible model
Machine temperature tuning thermistor	AKZ-OP-K5	(5 m)		Machine temperature tuning control (embedded in machine body)	AKZ**A (10 series)
	AKZ-OP-K10	(10 m)			
	AKZ-OP-K15	(15 m)			
	AKZ-OP-A5	(5 m)		Machine temperature tuning control (attached to machine body surface)	
	AKZ-OP-A10	(10 m)			

Characteristics of thermistor: Resistance R25 (resistance at 25°C) = 20 kΩ, Tolerance: ±3% (Temperature equivalent: ±0.4°C)

### Mounting procedure

#### OILCON

Connect the bar-type terminal plug [30]-[31] of the signal terminal block on the control board. (No polarity)  
(See "About the electrical equipment box" on page 12.)

#### Main machine

##### For AKZ-OP-K

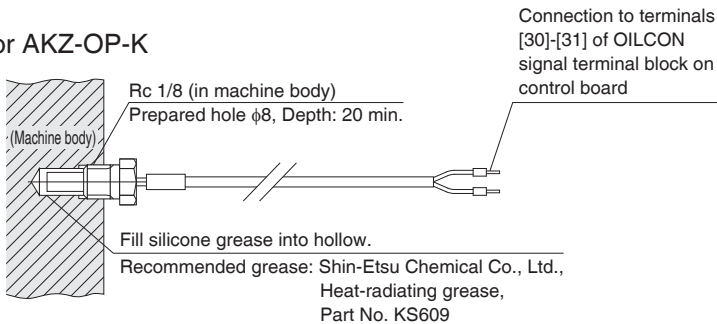

##### For AKZ-OP-A

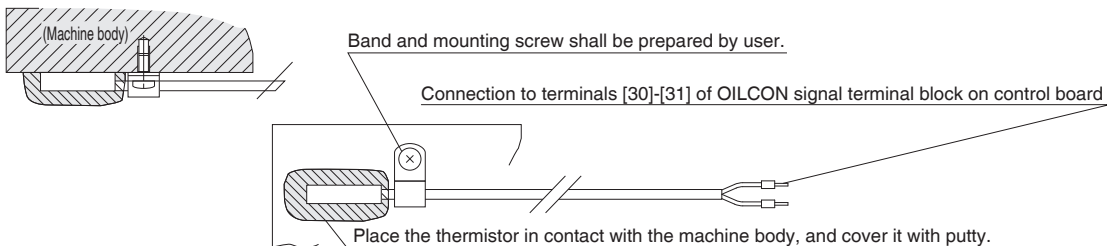

**CAUTION**

- If the sensor is directly exposed to wind, detected temperature may fluctuate. Be sure to take heat-insulation measures by applying putty.
- When using a sensor of screw-mounting type, screw the sensor all the way into the body of the detection target.

When the following optional parts are mounted to the oil piping (return oil piping) of the main machine, the OILCON can perform control by detecting the returned oil temperature.

## Optional parts

Name	Type	Lead wire length L (m)	Dimensions	Application (Installed by user)	Compatible model
Oil temperature control thermistor	AKZ-OP-Y5	(5 m)		Returned oil temperature control (Mounted to main machine oil piping)	AKZ**A (10 series)
	AKZ-OP-Y10	(10 m)			

Characteristics of thermistor: Resistance R25 (resistance at 25°C) = 20 kΩ, Tolerance: ±3% (Temperature equivalent: ±0.4°C)

## Mounting procedure

### OILCON

Substitute the blue connector (XHP-3) of the above part for the blue connector [CN11] of the outlet oil thermistor in the electrical equipment box. (See “About the electrical equipment box” on page 12.)

### Main machine

For AKZ-OP-Y

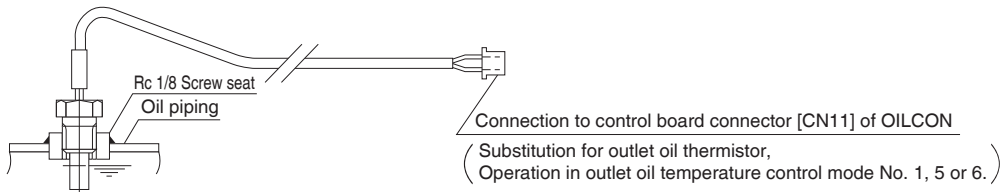

### Mounting position

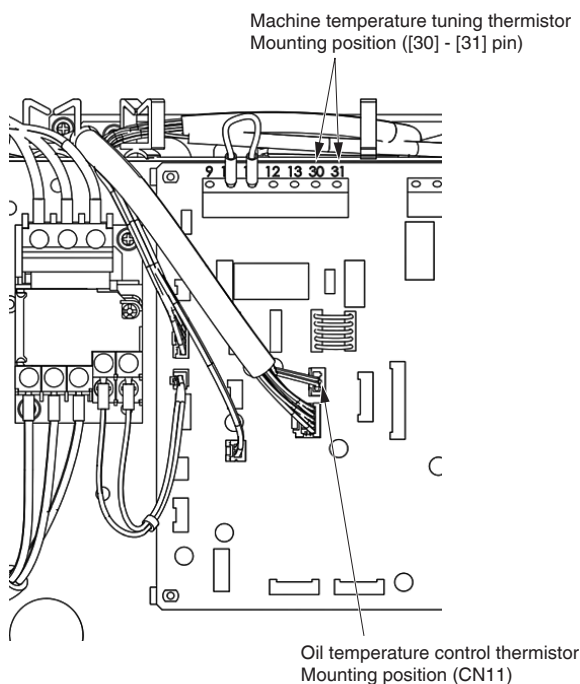

Optional Parts (Sold Separately)

Optional Functions

# Communication with main machine

When this optional board is mounted to the OILCON to connect this unit to the main machine:

1. You can change the operation mode and control target value from the main machine.
2. You can read the OILCON alarm code and temperature data (machine temperature, room temperature, inlet oil temperature, outlet oil temperature, temperature difference between inlet and outlet, and inverter frequency data) from the main machine.

## Optional parts

Communication method	Type	Compatible model	Specification No.
Serial communication	AKZA-OP-CS	AKZ**A (10 series)	PSP07465
Serial / Parallel communication	AKZA-OP-CSP	AKZ**A (10 series)	PSP07466

## Mounting procedure

### AKZA-OP-CS

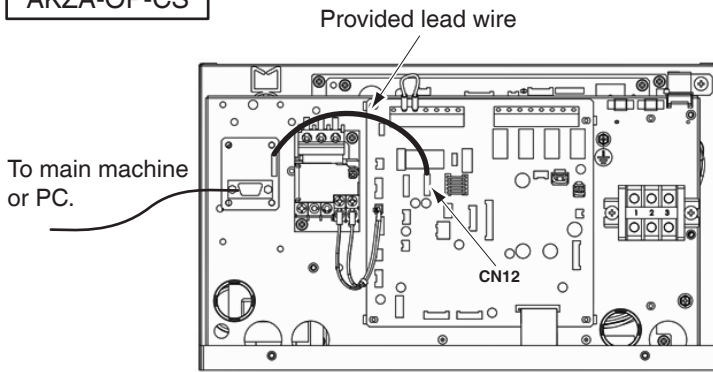

Connect to CN12 of the control board of OILCON with the provided lead wire.

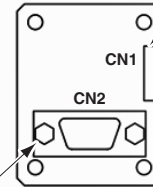

Connect to the RS232C port of the main machine or PC.  
(D-SUB 9-pin female)

### AKZA-OP-CSP

The position at which mounting is possible varies depending on the model.

Models: AKZ14A,32A,43A  
AKZ56A,90A

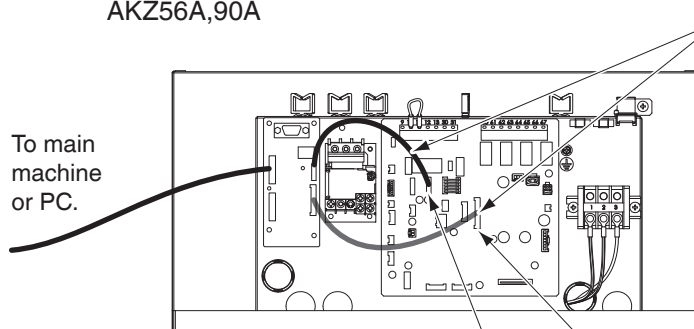

Connect to the RS232C port of the main machine or PC.  
(D-SUB 9-pin female)

Connect to CN12 of the control board of OILCON with the provided lead wire.

Models: AKZ56A,90A

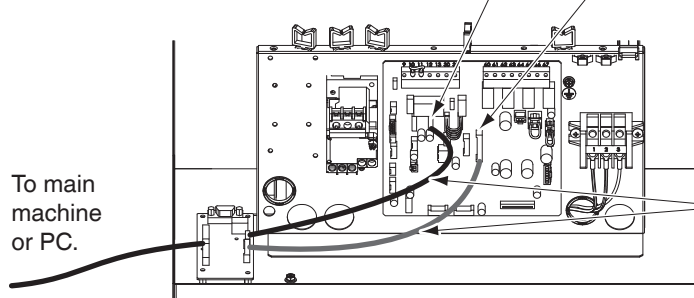

Connect to the output of the main machine PLC.

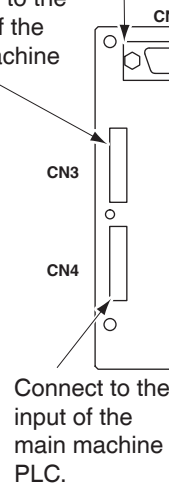

Connect to the input of the main machine PLC.

Connect to S151 of the control board of OILCON with the provided lead wire.

# Maintenance/Inspection

## Daily maintenance/inspection

- Oil pollution causes a fault or shortened service life of the pump motor. Use thorough caution about oil pollution to maintain the pollution degree at NAS10 or lower level.
- Keep a normal oil level in the oil tank (Between the yellow line and red line of the oil level gauge). Make sure that the oil does not contain air bubbles.
- Clean inside of the oil tank periodically.
- Make sure that the main machine oil piping is not blocked (fully closed).
- Make sure that the oil piping has no oil leak.
- Check that the voltage of the power supply is within the range specified.
- Make sure that the compressor, fan motor and pump do not abnormally sound during operation.
- Make sure that the OILCON does not abnormally shake during operation.
- Check whether the sheath of the OILCON power lead is not broken.

## Periodic maintenance/inspection

### Suction strainer

- Clean the suction strainer every six months to prevent the pump flow rate from being reduced by dust clogging, and to prevent abnormal sound caused by cavitation.

### Air filter (See page 17.)

NOTE: Wear gloves when working as the fins of the condenser may cause injury while replacing the air filter.

- Be sure to wash the air filter with water at 40°C or lower temperature every two weeks.  
If the air filter is clogged with dust, the wind volume reduces, resulting in capacity deterioration. Also, the compressor's protection device is activated, hindering smooth operation. Furthermore, it causes power consumption increase.
- Operating the unit without the air filter causes a fault.
- To remove the air filter, first remove the room thermistor, then lift the air filter up and pull it forward and out.

If the air filter is clogged, the cooling capacity deteriorates, resulting in excess power consumption. Clean the air filter periodically to save power consumption.

### Condenser (See page 17.)

- Check whether there are any substances in the condenser by removing the air filter (You do not need to remove the external plate).
- If the condenser becomes extremely dirty, clean it with a brush, air blower, etc.
- However, do not use water or cleaning agents for cleaning. The fan motor or pump motor may cause an earth leakage.

### Exterior

- Wipe the exterior surface with a dry cloth.  
**Never splash water over it.**
- To clean the exterior, do not use a brush, polish powder, acid, solvent (benzine etc.) or hot water. Using such substances causes the paint to peel off.

### Evaporator (See page 17.)

- Perform inspect the evaporator regularly as the piping becomes blocked (fully closed) because the internal gaps are clogged with dirt. The inside of the evaporator cannot be checked as it is sealed. Check the oil flow rate at the customer's oil piping from the OILCON output (You do not need to remove the external plate).

### Oil drain (drain pan) (See page 17.)

- Inspect the bottom of OILCON (drain pan) every six months and if the oil is accumulated, discharge it from the oil drain port. The tightening torque of the hexagonal bolt for the drain is 2N·m.  
If it is tightened with excessive torque, the bottom frame may be damaged.

### Sealing material of the electrical equipment box cover

- If the sealing material of the electrical equipment box cover is seriously damaged, consult Nearby Service Network. If you use the product without a change, the protection structure of IP54 cannot be maintained and the electric component may break down.

## To leave the unit unused for a long period

- Mount a cover to the OILCON to prevent dust or water from entering inside of the unit.
- Be sure to turn OFF the main power supply.
- Be careful to keep oily dust off the condenser surface of the OILCON.



# Troubleshooting

1. When the OILCON does not work well, first check the following points.

2. If the problem persists, contact Nearby Service Network with information on the following 1), 2) and 3) items. (See the back cover.)

- 1) Machine name (Full Model No.)
- 2) Manufacture No. (MFG. No.)
- 3) Condition of the OILCON

NOTE: Customers should not perform any repairs as it is dangerous. Our service person will make repairs.



**DANGER**

When checking by opening the electrical equipment box cover, be sure to turn OFF the main power supply and wait at least 5 minutes before opening the electrical equipment box cover.

## When the unit operation seems abnormal although no alarm is activated

Item	Condition	Cause	Corrective action
1	The unit does not run at all. (The POWER lamp on the control panel is unlit.)	(1) The main power supply is OFF.	Check that power is supplied to the power supply terminal.
		(2) (for models with a breaker) The electric component breaker has tripped. Or, it has not been turned ON.	Open the electrical equipment box cover and check if the breaker has tripped.
		(3) The wiring that supplies power to the control board is disconnected or broken.	Check the wiring between the control board and the inverter board.
2	The control panel displays "ACF" and then turns off.	(1) The main power supply is OFF.	This is the normal operation when the main power supply is OFF. No particular corrective action is required.
3	All the lamps on the control panel blink repeatedly.	(1) The voltage of the main power supply is insufficient.	Check that the supply voltage is within the specified operating range.
4	The pump/fan motor is operating, but the control panel is unlit.	(1) The wiring for the control panel is disconnected or broken.	Check the wiring between the control board and the control panel.
5	Pump motor/fan motor does not run.	(1) The remote control input ([10]–[11]) is OFF.	Check the connection of the remote control input.
		(2) The unit has been set to the operation lock mode. (With the factory setting, the operation lock mode is selected.)	Cancel the operation lock mode on the control panel. (See page 19.)
		(3) The pump motor wiring is disconnected.	Check the pump motor wiring.
6	Oil does not flow, although the pump is running. Because the oil circulation quantity is insufficient, the pump sound level is large.	(1) The pump suction pipe connection is loose.	Check the seal of the pipe and retighten.
		(2) The suction strainer is clogged.	Clean the suction strainer. If the oil in the oil tank is dirty, replace the oil. (See page 38.)
		(3) The oil level in the oil tank has decreased.	Refill oil into the oil tank.
		(4) Because of a large pressure loss in the oil discharge pipe, the pump relief valve is activated.	Increase the oil pipe diameter, and shorten the pipe length.
		(5) Because of a large pressure loss in the oil suction pipe, cavitation has occurred with the pump.	Check that the oil viscosity is within the specified operating range.
7	The compressor does not run, although the pump is running.	(1) The compressor is stopped under temperature control.	---
		(2) The compressor restart prevention timer has been activated.	Check if the compressor starts after elapse of the timer time (about 2 minutes).
		(3) The low oil temperature protection device has been activated. (Inlet oil temperature is 2°C or lower.)	Check if the compressor normally operates at 5°C or higher oil temperature.
		(4) The low ambient temperature protection device has been activated. (Room temperature is -2°C or lower.)	Check if the compressor normally operates at 0°C or higher room temperature.
		(5) The capacity setting is 0% (Operation mode 9).	Operate in an operation mode appropriate for use.

Item	Condition	Cause	Corrective action
8	Although both pump motor and compressor are running, oil cannot be cooled.	(1) There is an obstacle near the air intake/exhaust port.	Do not place any object that blocks ventilation at 500 mm or shorter distance from the air intake/exhaust port.
		(2) The air filter is clogged.	Clean the air filter.
		(3) The unit is running under capacity suppressing control, because the room temperature is high.	Check the capacity in the operating temperature range with the catalog, and select a model with appropriate capacity.
		(4) Heat load is large.	
		(5) The oil viscosity is high.	The higher the oil viscosity, the lower the cooling capacity. Select a model with appropriate capacity.
		(6) The temperature setting is high.	Change the temperature setting to an appropriate temperature.
		(7) If the exhaust air temperature is almost equal to the room temperature although the compressor is in operation, the refrigerant gas is running short.	Contact Nearby Service Network.
9	The operation settings cannot be changed	(1) If "---" appears on the data display, the temperature sensor corresponding to the selected operation mode is not connected.	Connect the required temperature sensor before changing the operation settings. The machine temperature tuning thermistor option is required for machine temperature tuning control.
		(2) If "---" instantaneously appears when the [ENT] key (at the right end of the control panel) is pressed, the protect switch is set to ON.	Turn OFF the protect switch on the control board.
10	Alarm output operation ([64]-[65]) is different from that of conventional signal output	(1) The alarm output signal connection has been partially changed depending on the series.	The [60]-[63] outputs are compatible with the AKS5 and AKZ6 series, but after the 7 series, signal operations and connections of the [64]-[65] outputs have been changed.

### When an alarm is activated

An alarm is generated when a defect that disables the continuance of operation is generated in OILCON.  
To cancel the alarm, turn OFF the power supply, and then turn it ON again.

### Alarm list

Alarm code	Alarm level	Description	Cause	Corrective action
AA	2	Heater overheat (-H model only)	(1) No oil flow.	Check if the oil circuit is properly connected and the pump motor normally operates.
			(2) The oil viscosity is out of the specified operating range.	Use an oil with a viscosity within the specified operating range.
			(3) The thermostat wiring is broken or disconnected.	Contact Nearby Service Network.
A6	2	DC fan motor lock error	(1) The wiring for the DC fan motor is disconnected or short-circuited.	Check the wiring connection.
			(2) There is an obstacle near the air intake/exhaust ports.	Do not place any object that blocks ventilation at 500 mm or shorter distance from the air intake/exhaust port.
			(3) Fault of the DC fan motor.	Contact Nearby Service Network.
E1	2	System error	(1) Internal parameter setting is invalid.	Contact Nearby Service Network.
E3	2*	High pressure error	(1) The oil temperature or room temperature is higher than the specified range.	Use the unit within the specified operating range.
			(2) There is an obstacle near the air intake/exhaust port.	Do not place any object that blocks ventilation at 500 mm or shorter distance from the air intake/exhaust port.
			(3) The air filter is clogged, or the condenser is dirty.	Clean the air filter. (See "Maintenance/Inspection" on page 38.)
			(4) Any factor other than the above.	Contact Nearby Service Network.
E5	2*	Compressor high temperature error	(1) The oil temperature or room temperature is higher than the specified range.	Use the unit within the specified operating range.
			(2) There is an obstacle near the air intake/exhaust port.	Do not place any object that blocks ventilation at 500 mm or shorter distance from the air intake/exhaust port.
			(3) The air filter is clogged, or the condenser is dirty.	Clean the air filter. (See "Maintenance/Inspection" on page 38.)
			(4) Any factor other than the above.	Contact Nearby Service Network.

Alarm level 1 ... The compressor (Heater), pump motor, and fan motor stop

Alarm level 2 ... Only the compressor (Heater) stops

\* However, in the case of E3 when the High-pressure switch (CE/UKCA model only) is operating and E5 when the compressor protection thermostat is operating, the fan motor stops at the same time.

Alarm code	Alarm level	Description	Cause	Corrective action
E6	2	Compressor lock	(1) Fault of the compressor. (Replace the compressor.)	Contact Nearby Service Network.
E9	2	Electronic expansion valve coil (for main circuit or hot gases) circuit error	(1) The connector of the electronic expansion valve coil (for main circuit or hot gases) is disconnected.	Check the insertion of the relevant expansion valve coil connector.
			(2) The fuse in the electronic expansion valve coil (for main circuit or hot gases) circuit has blown.	Contact Nearby Service Network.
			(3) The electronic expansion valve coil (for main circuit or hot gases) is disconnected or short-circuited.	Contact Nearby Service Network.
EH	1	Pump motor over-current relay is activated.	(1) The pump is overloaded with high-viscosity oil.	Use an oil with a viscosity within the specified operating range.
			(2) Because the power supply voltage is outside the specified operating range, the pump motor current has increased.	Check if the power supply voltage is within the specified operating range. Check for an instantaneous power supply voltage drop at startup of peripheral equipment.
			(3) The pump motor wiring has a break. (Open-phase)	Contact Nearby Service Network.
			(4) A foreign object is caught in the pump, or the pump motor has a fault.	Contact Nearby Service Network.
EJ	1 or 2	Optional protection device is activated.	(1) The optionally-connected protection device (or factory-connected device, if it is incorporated in the unit) has been activated.	Check the condition detected with the relevant protection device.
			(2) (Only with heater) Oil does not flow, and the protection device has been activated.	Check if the oil circuit is properly connected and the pump normally operates.
F1	2	Temperature error alarm 1	(1) The monitor temperature has exceeded the preset temperature. (It does not mean a fault of the OILCON)	Check the preset temperature range warning condition. (Parameters n010 to n019) (See "Parameter setting" on page 29-31.)
F2	2	Temperature error alarm 2		
F3	2	Temperature error alarm 3		
F4	2	Temperature error alarm 4		
F5	2	Temperature error alarm 5		
FE	1	High oil temperature error The oil temperature is higher than 65°C.	(1) Oil does not flow.	Check if the oil piping system is not blocked (fully closed).
FH	2	The inlet oil temperature has exceeded 60°C.	(1) The amount of heat generated by the main machine has exceeded the cooling capacity of OILCON. (Model selection error)	If it is installed correctly and the compressor is operating at 100% capacity (can be checked in Monitor mode), select a model with a larger cooling capacity.
			(2) There is an obstacle near the air intake/exhaust port, so the cooling capacity is reduced.	Do not place any object that blocks ventilation at 500 mm or shorter distance from the air intake/exhaust port.
			(3) The temperature exceeds the value at standard point (room temperature and inlet oil temperature: 35°C) and the unit is running under capacity suppressing control.	If the values at standard point are exceeded, the cooling capacity will drop below the nominal capacity because the unit is running under capacity suppressing control. Make sure that the cooling capacity of OILCON exceeds the amount of heat generated by the main machine over the entire temperature range used.
			(4) The oil temperature is not controlled because it is operating in the operation mode: 9 (capacity direct command).	Operate in an operation mode appropriate for use. (Capacity direct command does not perform temperature feedback control)
			(5) Refrigerant gas is missing.	If the exhaust air temperature is almost equal to the room temperature although the compressor is in operation, the refrigerant gas may leak, so contact Nearby Service Network.
H0	2	Machine temperature tuning thermistor error (Optional)	(1) The machine temperature tuning thermistor (optional) is disconnected or short-circuited.	Check the wiring of the machine temperature tuning thermistor. <Emergency Operation> Malfunction of machine temperature tuning thermistor: Emergency operation is available when the operation mode is 0, 1, 3 or 5. (See page 22-24 to change the operation mode.)
H1	2	Room thermistor error	(1) Room thermistor is disconnected or short-circuited.	Check the wiring of the room thermistor. <Emergency Operation> Malfunction of room thermistor: Emergency operation is available when the operation mode is 0, 1, 4 or 6.** (See page 22-24 to change the operation mode.)

Alarm code	Alarm level	Description	Cause	Corrective action
JH	2	Inlet oil thermistor error	(1) Inlet oil thermistor is disconnected or short-circuited.	<Emergency Operation> Malfunction of inlet oil thermistor: Emergency operation is available when the operation mode is 1, 5 or 6.** (See page 22-24 to change the operation mode.)
JJ	2	Outlet oil thermistor or returned oil thermistor (optional) error	(1) The outlet oil thermistor or returned oil thermistor (optional) is disconnected or short-circuited.	<Emergency Operation> Malfunction of outlet oil thermistor or returned oil thermistor: Emergency operation is available when the operation mode is 0, 3 or 4. (See page 22-24 to change the operation mode.)
L4	2	Power device temperature error	(1) The oil temperature or room temperature is higher than the specified range.	Use the unit within the specified operating range.
L5	2	Instantaneous over-current of power device	(2) There is an obstacle near the air intake/exhaust port.	Do not place any object that blocks ventilation at 500 mm or shorter distance from the air intake/exhaust port.
			(3) The air filter is clogged, or the condenser is dirty.	Clean the air filter. (See "Maintenance/Inspection" on page 38.)
			(4) Failure of compressor or inverter board.	Contact Nearby Service Network.
L8	2	Compressor overload	(1) Failure of compressor or inverter board.	Contact Nearby Service Network.
L9	2	Compressor start failure		
LA	2	Instantaneous over-current of power device		
LC	2	Transmission error between inverter board and control board CPU	(1) Communication error due to breakage of wiring or disconnection of connector.	Check the wiring between the inverter board and control board.
			(2) Communication failure between the temperature control microprocessor and the inverter microprocessor.	Replace the control board or replace the inverter board, or improve the power supply environment (take noise suppressing measures.)
U0	2	Out of gas	(1) Refrigerant gas is leaking due to damage to the refrigerant piping from excessive transportation vibration.	The refrigerant piping needs to be repaired and refilled with refrigerant. Contact Nearby Service Network.
U1	1	Power supply reverse phase/open phase	(1) The power supply is connected in reverse phase.	Exchange any phase of the power supply wiring.
			(2) Open phase.	Make sure that any phase is properly connected to the power supply terminal block.
			(3) A foreign object is caught in the pump, or the pump motor has a fault.	Contact Nearby Service Network.
			(4) The fuse in the noise filter board has blown.	Contact Nearby Service Network.
U2	2	Low voltage (DC voltage on main Inverter circuit)	(1) Decrease of the DC voltage of the main circuit due to insufficient main power supply voltage.	Check if the power supply voltage is not lower than the specified operating range. Also, check for instantaneous power supply voltage drop at startup of peripheral equipment.
			(2) Circuit protection for surge current restriction is activated because of excess ON/OFF switching of power supply.	Turn OFF the power supply, and turn it ON again after two minutes or more. Frequent turning ON/OFF of the power supply may cause failure of OILCON. Ensure the power ON time and OFF time is for two minutes or more separately.
			(3) Unconnection of DCL.	Check the DCL wiring.
			(4) Decrease of the DC voltage of the main circuit due to breaking of wiring or disconnection of connector.	Check the wiring between the filter board and the inverter board.
			(5) Power voltage sag (interrupt) often occurs.	Make sure that the power supply voltage conforms to the rating. Check for instantaneous voltage drop at startup of peripheral equipment.
			(6) Filter board relay circuit failure.	Contact Nearby Service Network.
U9	2	Other system communication error (Slave communication error)	(1) An error occurred in communication with a slave.	Make sure that the slave communication line is properly connected. (This error occurs only when the slave does not make response in master-slave communication.)
UH	1	System failure (EEPROM error)	(1) The parameter stored in the control board or inverter board is invalid.	Contact Nearby Service Network.
UJ	1 or 2	Optional protection device is activated.	(1) The optionally-connected protection device (or factory-connected device, if it is incorporated in the unit) has been activated.	Check the condition detected with the relevant protection device.
J3	2	Discharge pipe thermistor error	(1) The discharge pipe thermistor is disconnected or short-circuited.	Contact Nearby Service Network.
J4	2	Electronic expansion valve outlet thermistor error	(1) The electronic expansion valve outlet thermistor is disconnected or short-circuited.	Contact Nearby Service Network.
J6	2	Condenser thermistor error	(1) The condenser thermistor is disconnected or short-circuited.	Contact Nearby Service Network.

\*\* When changed to emergency operation, a warning will be activated, so the thermistor must be replaced or repaired as soon as possible. Contact Nearby Service Network.

## When a warning is activated

A warning is generated when the status of OILCON is not normal or the oil temperature to be monitored exceeds the setting temperature range.

If you continue operation without a change, OILCON may break down. Be sure to take measures.

## Warning list

Warning code	Description	Cause	Corrective action
F6	High pressure error	(1) There is an obstacle near the air intake/exhaust port.	<ul style="list-style-type: none"> <li>• Clean the air filter and condenser.</li> <li>• Do not place any object that blocks ventilation at 500 mm or shorter distance from the air intake/exhaust port.</li> </ul>
		(2) Operation at room temperature outside the specified operating range.	Use the unit within the specified operating range.
H1	Room thermistor error	(1) Room thermistor is disconnected or short-circuited. (When not used for control)	Check the wiring of the relevant thermistor.
JH	Inlet oil thermistor error	(1) Inlet oil thermistor is disconnected or short-circuited.	Check the wiring of the relevant thermistor.
J3	Discharge pipe thermistor error	(1) The discharge pipe thermistor is disconnected or short-circuited. The system will be stopped to protect OILCON by upgrading the state to an alarm after operation for 150 hours.	Check the wiring of the relevant thermistor.
J4	Electronic expansion valve outlet thermistor error	(1) The electronic expansion valve outlet thermistor is disconnected or short-circuited. The system will be stopped to protect OILCON by upgrading the state to an alarm after operation for 150 hours.	Check the wiring of the relevant thermistor.
J6	Condenser thermistor error	(1) The condenser thermistor is disconnected or short-circuited. The system will be stopped to protect OILCON by upgrading the state to an alarm after operation for 150 hours.	Check the wiring of the relevant thermistor.
P4	Fin thermistor error	(1) Fin thermistor is disconnected or short-circuited.	Turn OFF the power supply, and turn it ON again. A protection device with an alternative function will be activated.
1E	Temperature range warning 1	(1) The monitor temperature has exceeded the preset temperature. (It does not mean a fault of the OILCON.)	Check the preset temperature range warning condition. (Parameters n010 to n019) (See "Parameter setting" on page  for settings)
2E	Temperature range warning 2		
3E	Temperature range warning 3		
4E	Temperature range warning 4		
5E	Temperature range warning 5		

# Specifications Table

## Specifications (AKZ14A • 32A • 43A)

OILCON equivalent horsepower (HP)		0.5						1.2						1.5									
Model		AKZ14A						AKZ32A						AKZ43A									
		Stand- ard	-B	-C	-J	-H	-T	Different-voltage <sup>*3</sup>	Stand- ard	-B	-C	-J	-H	-T	Different-voltage <sup>*3</sup>	Stand- ard	-B	-C	-J	-H	-T	Different-voltage <sup>*3</sup>	
Cooling capacity (50/60 Hz) <sup>*1</sup>	kW	1.3/1.4						2.8/3.2						3.8/4.3									
Heater (at 200 V)	kW	1						1						1									
Power supply <sup>*2</sup>		3-phase 200/200 · 220 VAC 50/60 Hz						3-phase 200/200 · 220 VAC 50/60 Hz						3-phase 200/200 · 220 VAC 50/60 Hz									
Circuit voltage	Main circuit <sup>*3</sup>	3-phase 200/200 · 220 VAC 50/60 Hz																					
	Operation circuit	12/24 VDC																					
Max. power consumption	200 V 50Hz	0.90 kW/3.9A						1.36 kW/5.2A						1.80 kW/6.6A									
	200 V 60Hz	0.91 kW/3.6A						1.43 kW/5.1A						1.88 kW/6.4A									
	220 V 60Hz	0.91 kW/3.5A						1.43 kW/4.9A						1.88 kW/6.1A									
Max. current consumption	200 V 50Hz	1.29 kW/4.1A						1.51 kW/5.4A						1.51 kW/5.4A									
	200 V 60Hz	1.32 kW/4.2A						1.60 kW/5.4A						1.60 kW/5.4A									
Heating	200 V 50Hz	1.55 kW/4.5A						1.83 kW/5.7A						1.83 kW/5.7A									
	220 V 60Hz	1.55 kW/4.5A						1.83 kW/5.7A						1.83 kW/5.7A									
Transformer capacity		2.6 kVA						2.6 kVA						2.6 kVA									
Exterior color		Ivoly White																					
Outer dimensions (H x W x D)	mm	650 x 360 x 440	950 x 360 x 440	810 x 360 x 465	950 x 360 x 440	775 x 360 x 440	1075 x 360 x 440	965 x 360 x 465	1075 x 360 x 440	875 x 360 x 440	1175 x 360 x 440	1065 x 360 x 465	1175 x 360 x 440										
Compressor (Hermetic DC swing type)		Equivalent to 0.4 kW						Equivalent to 0.75 kW						Equivalent to 1.1 kW									
Evaporator		Cross fin coil type																					
Condenser		Cross fin coil type																					
Fan	Motor	54 W																					
	Motor	0.4 kW x 4P																					
Oil pump	Discharge rate	12/14.4						24/28.8															
	Clacking pressure	0.5						0.6															
Temperature control (Selectable)	Tuning type	Reference	Room temperature or machine temperature <sup>*4</sup> (Factory setting: Room temperature: Mode 3)																				
		Control target	Inlet oil temperature or outlet oil temperature (Factory setting: Inlet oil temperature)																				
	Tuning range	°C Within ±9.9 relative to reference temperature (Factory setting: 0.0)																					
	Fixed type	Control target	Inlet oil temperature or outlet oil temperature																				
Range		°C 5-50																					
Refrigerant control		Inverter compressor rotation speed + Electronic expansion valve opening																					
Refrigerant: R410A (GWP :2090) <sup>*5</sup>	Loading weight	kg 0.54						0.81						0.83									
	Carbon dioxide equivalent value	tCO <sub>2</sub> eq 1.13						1.70						1.74									
Protection device		Over-current relay (Pump motor), Reverse-phase protector, Restart prevention timer, Low room temperature protection thermistor, High oil temperature protection thermistor, Low oil temperature protection thermistor, Pump relief valve, Discharge pipe thermistor, Condenser thermistor, Refrigerant leak detector, Inverter protector, High-pressure pressure switch ("C" only), Compressor protection thermostat, Overheating protection thermostat ("H" only), Oil lack prevention switch ("B" only) Circuit breaker ("B" only)																					
Operating range	Room temperature	°C 5-45																					
	Inlet oil temperature	°C 5-50																					
	Oil viscosity	mm <sup>2</sup> /s 1.4-200 (ISO VG2-32)																					
External pressure loss	Discharge	0.5 MPa or less																					
	Suction	Within -30.7 kPa																					
Applicable oil		Lubrication oil, Mineral hydraulic oil (Phosphoric ester hydraulic oil, water/water-soluble liquid, chemical, food, fuel, cutting/grinding fluid cannot be used.)																					
Connection pipe	Oil inlet	Rc3/4																					
	Oil outlet	Rc3/4	Rc1 1/4	Rc3/4	Rc3/4	Rc1 1/4	Rc3/4	Rc3/4	Rc3/4	Rc1 1/4	Rc3/4												
	Oil drain	Rc1/4 (Fastened with plug)																					
Sound level (Measured at 1 m from front of unit, at 1.55 m height, in anechoic room)	dB (A) <sup>*7</sup>	62						65															
Transportation vibration resistance <sup>*8</sup>		Vertical: 14.7m/s <sup>2</sup> x 2.5hr (7.5 to 100Hz sweep/5min)																					
Ingress protection		IP2X <sup>*8</sup>																					
Weight	kg	57	83	77	93	63	89	83	99	65	95	82	103										
Internal wiring circuit breaker (Rated current)	A	- 10				- 10				- 10													
Oil tank (Volume)	L	-						15 <sup>*10</sup>						-									
Local procurement item	Earth leakage circuit breaker (Rated current) <sup>*9</sup>	A 10						10						10									

### Model identification

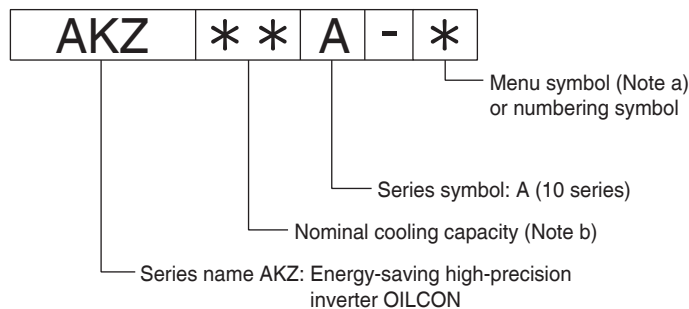

(Note a) Menu symbol

- B : With built-in breaker
- C : CE/UKCA-conformable
- J : Modbus communication
- H : Built-in heater
- T : Built-in tank
- Different-voltage (\*3)
  - 046 : 220 VAC, 230 VAC 50/60 Hz
  - 048 : 440 VAC, 460 VAC, 480 VAC 50/60 Hz

(Note b) Nominal cooling capacity

Indicates cooling capacity at standard point with commercial power supply frequency of 60 Hz. (Inlet oil temperature and room temperature: 35°C, VG32-equivalent oil is used, 1 atm.)

- 14 : 1.4 kW
- 32 : 3.2 kW
- 43 : 4.3 kW
- 56 : 5.6 kW
- 90 : 9.0 kW

# Specifications (AKZ56A • 90A)

OILCON equivalent horsepower (HP)		2.0						3.0							
		AKZ56A						AKZ90A							
Model		Stand-ard	-B	-C	-J	-H	-T	Different-voltage <sup>*3</sup>	Stand-ard	-B	-C	-J	-H	-T	Different-voltage <sup>*3</sup>
Cooling capacity (50/60 Hz) <sup>*1</sup>	kW	5.0/5.6						8.0/9.0							
Heater (at 200 V)	kW	2						3							
Power supply <sup>*2</sup>		3-phase 200/200 · 220 VAC 50/60 Hz						3-phase 200/200 · 220 VAC 50/60 Hz							
Circuit voltage	Main circuit <sup>*3</sup>	3-phase 200/200 · 220 VAC 50/60 Hz						3-phase 200/200 · 220 VAC 50/60 Hz							
	Operation circuit	12/24 VDC													
Max. power consumption	Cooling	200 V 50Hz	2.22 kW/7.6A						4.25 kW/13.5A						
		200 V 60Hz	2.30 kW/7.5A						4.30 kW/13.4A						
		220 V 60Hz	2.30 kW/7.2A						4.30 kW/12.9A						
Max. current consumption	Heating	200 V 50Hz	2.59 kW/9.3A						3.64 kW/12.4A						
		200 V 60Hz	2.68 kW/9.0A						3.73 kW/12.2A						
		220 V 60Hz	3.11 kW/9.7A						4.37 kW/13.2A						
Transformer capacity		4.0 kVA						6.0 kVA							
Exterior color		Ivoly White													
Outer dimensions (H x W x D)	mm	1110 x 470 x 500	1410 x 470 x 560	1375 x 470 x 580	1360 x 470 x 590	1220 x 560 x 620	1520 x 560 x 680	1485 x 560 x 700	1470 x 560 x 695						
Compressor (Hermetic DC swing type)		Equivalent to 1.5 kW						Equivalent to 2.2 kW							
Evaporator		Braze plate type													
Condenser		Cross fin coil type													
Fan	Motor	100 W													
Oil pump	Motor	0.7 kW x 4P													
	Discharge rate	L/min						30/36							
	Clacking pressure	MPa						0.6							
Temperature control (Selectable)	Tuning type	Reference	Room temperature or machine temperature <sup>*4</sup> (Factory setting: Room temperature: Mode 3)												
		Control target	Inlet oil temperature or outlet oil temperature (Factory setting: Inlet oil temperature)												
	Fixed type	Control target	Within ±9.9 relative to reference temperature (Factory setting: 0.0)												
		Range	°C						5-50						
Refrigerant control		Inverter compressor rotation speed + Electronic expansion valve opening													
Refrigerant: R410A (GWP :2090) <sup>*5</sup>	Loading weight	kg						1.37							
	Carbon dioxide equivalent value	tCO <sub>2</sub> eq						2.87							
Protection device		Over-current relay (Pump motor), Reverse-phase protector, Restart prevention timer, Low room temperature protection thermistor, High oil temperature protection thermistor, Low oil temperature protection thermistor, Pump relief valve, Discharge pipe thermistor, Condenser thermistor, Refrigerant leak detector, Inverter protector, High-pressure pressure switch ("C" only), Compressor protection thermostat, Overheating protection thermostat ("H" only), Oil lack prevention switch ("H" only) Circuit breaker ("B" only)													
Operating range	Room temperature	°C						5-45							
	Inlet oil temperature	°C						5-50							
	Oil viscosity	mm <sup>2</sup> /s						1.4-200 (ISO VG2-32)							
	External pressure loss	Discharge	0.5 MPa or less												
	Suction	Within -30.7 kPa													
Applicable oil		Lubrication oil, Mineral hydraulic oil (Phosphoric ester hydraulic oil, water/water-soluble liquid, chemical, food, fuel, cutting/grinding fluid cannot be used.)													
Connection pipe	Oil inlet	Rc1 1/4						Rc1 1/4							
	Oil outlet	Rc1						Rc1 1/4							
	Oil drain	Rc1/4 (Fastened with plug)													
Sound level (Measured at 1 m from front of unit, at 1.55 m height, in anechoic room)	dB (A) <sup>*7</sup>	65						67							
Transportation vibration resistance <sup>*8</sup>		Vertical: 14.7m/s <sup>2</sup> x 2.5hr (7.5 to 100Hz sweep/5min)													
Ingress protection		IP2X <sup>(-9)</sup>													
Weight	kg	86		120		119		149		104		145		139	
Internal wiring circuit breaker (Rated current)	A	-		15		-		-		20		-		-	
Oil tank (Volume)	L	-		-		50 <sup>*10</sup>		-		-		70 <sup>*10</sup>		-	
Local procurement item	Earth leakage circuit breaker (Rated current) <sup>*9</sup>	A						15							
								20							

- Note) \*1: Cooling capacity is the value at standard point (inlet oil temperature and room temperature: 35°C, ISO VG32 oil, 1 atm). The product tolerance is approx. ±5%.
- \*2: Be sure to use a commercial power supply. Using an inverter power supply may result in burnout. Voltage fluctuation range should be within ±10%. If voltage fluctuation exceeds ±10%, consult Nearby Service Network.
- \*3: There are two types of different-voltage models, -046 and -048, depending on the power supply. -048 is supported with a transformer. Main circuit voltage with a transformer is the transformer secondary voltage 200 VAC 50/60Hz. (Since the -046 model does not have a transformer, the external dimensions and weight are the same as the standard model. The main circuit voltage is 220 · 230 VAC 50/60Hz.)
- \*4: The optional machine temperature tuning thermistor is required. (For details, see page 35.)
- \*5: The fluorinated greenhouse gases are contained in hermetically sealed. The "C" model is supplied with SDS (Safety Data Sheet) for refrigerant R410A.
- \*6: Electric unit protective structure: IP54 or equivalent (Use conduits higher than IP54 for the knock out hole)
- \*7: For energy-saving purposes, the rotation speed of a fan will vary according to the room temperature. This may change its noise level as well, but it does not constitute a failure.
- \*8: Performance for transportation vibration refers to the performance of standard units.
- \*9: No line breaker is included in this product. It must be separately provided by the customer.
- \*10: The yellow line on the tank liquid level gauge shows the highest oil level, and the red line shows the lowest liquid level.
- \*11: The table below shows the maximum power consumption and maximum current consumption for different-voltage models.

■ AKZ14A				■ AKZ32A				■ AKZ43A				■ AKZ56A				■ AKZ90A			
Power supply		Power/Current		Power supply		Power/Current		Power supply		Power/Current		Power supply		Power/Current		Power supply		Power/Current	
220V	50/60 Hz	0.91 kW	3.6A	220V	50/60 Hz	1.43 kW	4.8A	220V	50/60 Hz	1.88 kW	6.0A	220V	50/60 Hz	2.30 kW	7.3A	220V	50/60 Hz	4.30 kW	13.0A
230V		0.91 kW	3.4A	230V		1.43 kW	4.6A	230V		1.88 kW	5.8A	230V		2.30 kW	7.0A	230V		4.30 kW	12.4A
440V		0.92 kW	1.8A	440V		1.45 kW	2.4A	440V		1.90 kW	3.0A	440V		2.32 kW	3.5A	440V		4.33 kW	6.2A
460V		0.92 kW	1.7A	460V		1.45 kW	2.3A	460V		1.90 kW	2.9A	460V		2.32 kW	3.3A	460V		4.33 kW	5.9A
480V		0.92 kW	1.7A	480V		1.45 kW	2.2A	480V		1.90 kW	2.8A	480V		2.32 kW	3.2A	480V		4.33 kW	5.7A

# Electric wiring diagram (Typical: AKZ32A)

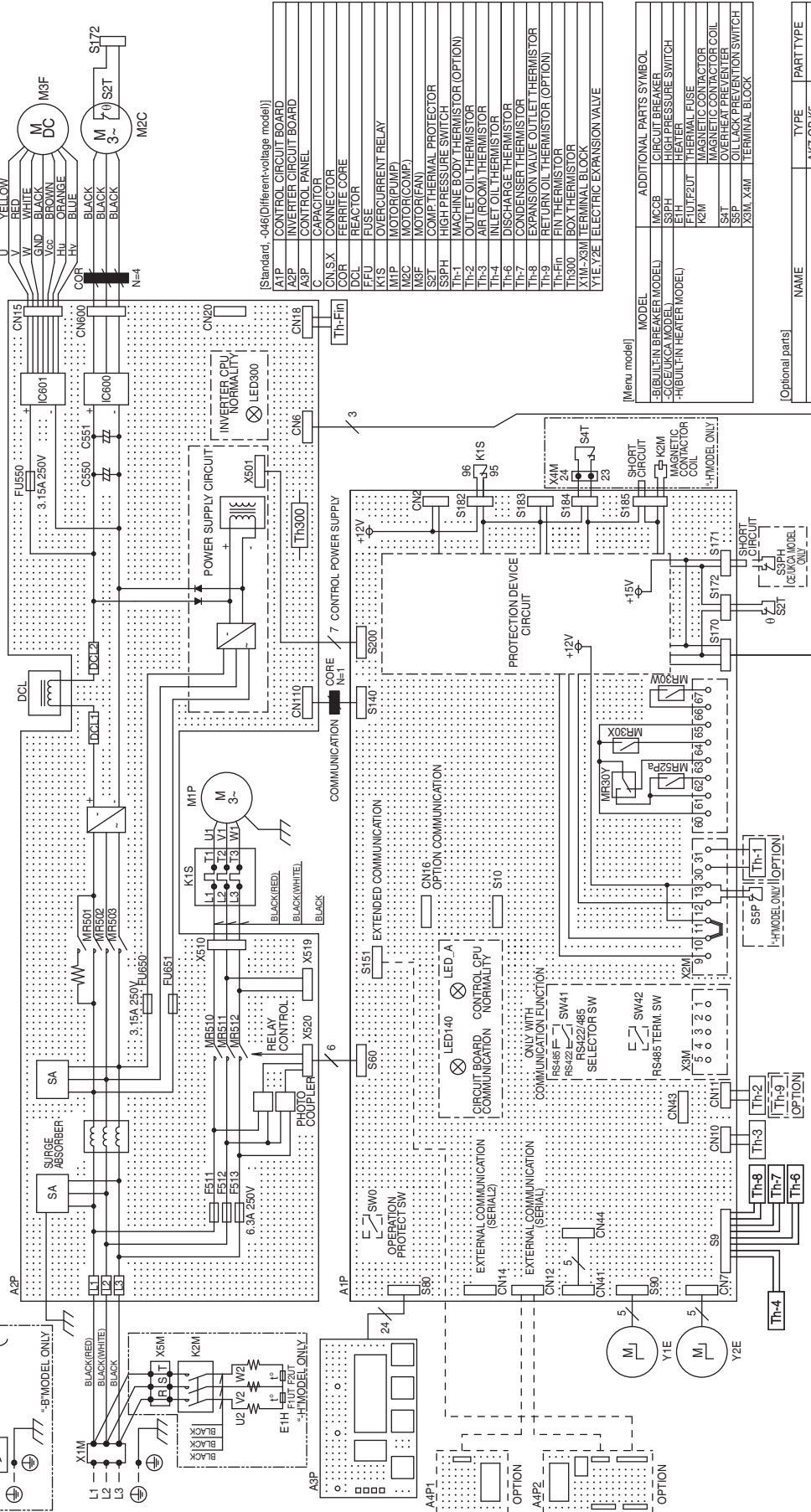
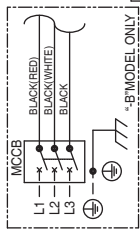
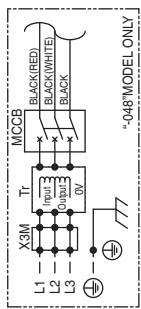

(Standard, -046 (Different-voltage model))

A1P	CONTROL CIRCUIT BOARD
A2P	INVERTER CIRCUIT BOARD
A3P	CONTROL PANEL
C	CAPACITOR
GN.S.X	CONNECTOR
COR	FERRITE CORE
DCL	REACTOR
FFU	FUSE
K1S	OVERCURRENT RELAY
M1P	MOTOR(PUMP)
M2C	MOTOR(COMP)
M3F	MOTOR(FAN)
S2T	COMPTHERMAL PROTECTOR
SSPH	HIGH PRESSURE SWITCH
Th-1	MACHINE BODY THERMISTOR (OPTION)
Th-2	OUTLET OIL THERMISTOR
Th-3	AIR ROOM THERMISTOR
Th-4	DISCHARGE THERMISTOR
Th-6	CONDENSER THERMISTOR
Th-7	EXPANSION VALVE OUTLET THERMISTOR
Th-8	RETURN OIL THERMISTOR (OPTION)
Th-9	FIN THERMISTOR
Th300	BOX THERMISTOR
X1M-X3M	TERMINAL BLOCK
Y1E, Y2E	ELECTRIC EXPANSION VALVE

(Menu model)

MODEL	ADDITIONAL PARTS SYMBOL
-CIBULIN BREAKER MODEL	MCCB
-CIBULIN HEATER MODEL	SSPH
-HIBULIN HEATER MODEL	ETH
	K2M
	FLU7F2UT
	K2M
	MAGNETIC CONTRACTOR COIL
	SSP
	OIL LOCK PREVENTION SWITCH
	X3M, X4M
	TERMINAL BLOCK

(Optional parts)

NAME	TYPE	PART TYPE
MACHINE BODY THERMISTOR (OPTION)	AKZ-OP-K5	Th-1
	AKZ-OP-K10	Th-1
	AKZ-OP-K15	Th-1
	AKZ-OP-K5	Th-9
	AKZ-OP-Y10	Th-9
RETURN OIL THERMISTOR (OPTION)	AKZ-OP-Y10	Th-9
EXPANSION BOARD FOR COMMUNICATION WITH MAIN MACHINE	AKZ-OP-C5	A4P1
	AKZ-OP-C5P	A4P2

(Note)  
 1. To use optional oil temperature control thermistor (Th-9), substitute it for the outlet oil thermistor (Th-2) on CN11.  
 2. For details, refer to the electric wiring diagram for each model.

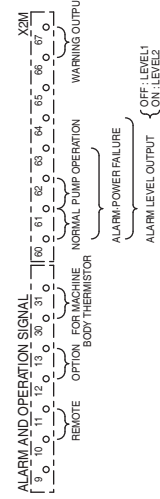





## Global Service Network

Please contact DAIKIN Sales Counter for servicing of OILCON in countries outside Japan.

Daikin is ready to offer you service in conjunction with the sales agents of our Air-conditioning and Hydraulic Divisions located in worldwide countries and regions.

Country/Region	State/City	Company name
East Asia	Shanghai	©KAILING HYDRAULICS TECHNOLOGY (Shanghai) CO.,LTD.
		DAIKIN AIR CONDITIONING TECHNOLOGY (Shanghai) CO.,LTD.
	Beijing	DAIKIN AIR CONDITIONING TECHNOLOGY (Beijing) CO.,LTD.
	Guangzhou	DAIKIN AIR CONDITIONING TECHNOLOGY (Guangzhou) CO.,LTD.
	Seoul	©KD HYDRAULICS,LTD.
	Taipei	HO TAI SERVICE & MARKETING CO.,LTD.
Singapore	Singapore	©ZICOM PRIVATE LTD.
Thailand	Bangkok	©NANDEE INTER-TRADE CO., LTD.
Indonesia	Jakarta	©PT. ETERNA KARYA SEJAHTERA
Viet Nam	Hanoi	©AN PHAT EQUIPMENT & ACCESSORIES CO., LTD.
Italy	Milan/Padova	©DIPLOMATIC MS S.P.A.
Germany	Neu-Ulm	©SAUER BIBUS GMBH
U.S.	Illinois	©ALL WORLD MACHINERY SUPPLY INC.
Mexico	Queretaro	©ALL WORLD MACHINERY SUPPLY INC. Mexico Branch

©: Sales desks for hydraulic and cooling equipment. The others are companies related exclusively to air conditioning.

(As of May 2023)

## DAIKIN INDUSTRIES, LTD.

Oil Hydraulic Equipment

### Osaka Office

YODOGAWA PLANT

1-1, Nishi-Hitotsuya, Settsu, Osaka 566-8585, Japan

Phone: 81-6-6349-4475

Fax.: 81-6-6349-7862

Home Page: <https://www.hyd.daikin.com>